



HPU HANDING CONFIRMATION

SO NUMBER
(INTERNAL USE)

WO NUMBER
(INTERNAL USE)

ROOF TOP PACKAGED UNITS (RTU)

GENERAL	This document details the airside configurations available on HPU models.
SOURCING	Standard configuration is detailed in the unit general arrangement drawings. Optional airside configurations to be specified at time of order.
HOW TO USE THIS DOCUMENT	<ol style="list-style-type: none"> 1. Choose if the supply air position is required on the left, on the right, or centred. 2. Circle the required supply air outlet. 3. Circle the required return air inlet. 4. Complete the information at the bottom of this document and return to your APAC representative.

LEFT HAND SUPPLY AIR APPLICABLE MODELS – P012-095AHR3SA

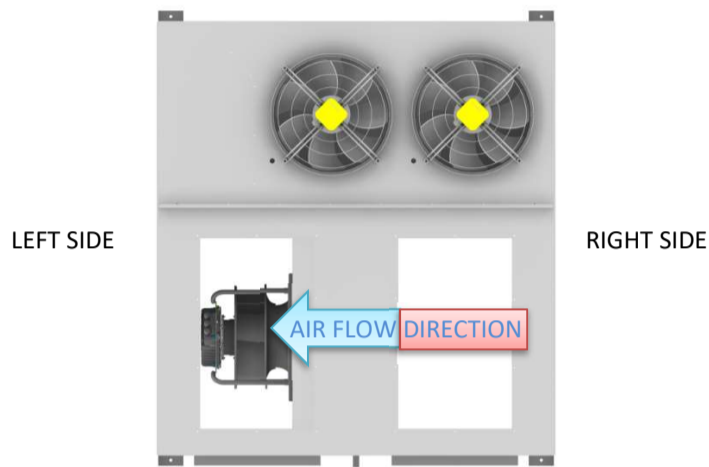

Fig1. Left hand unit top view

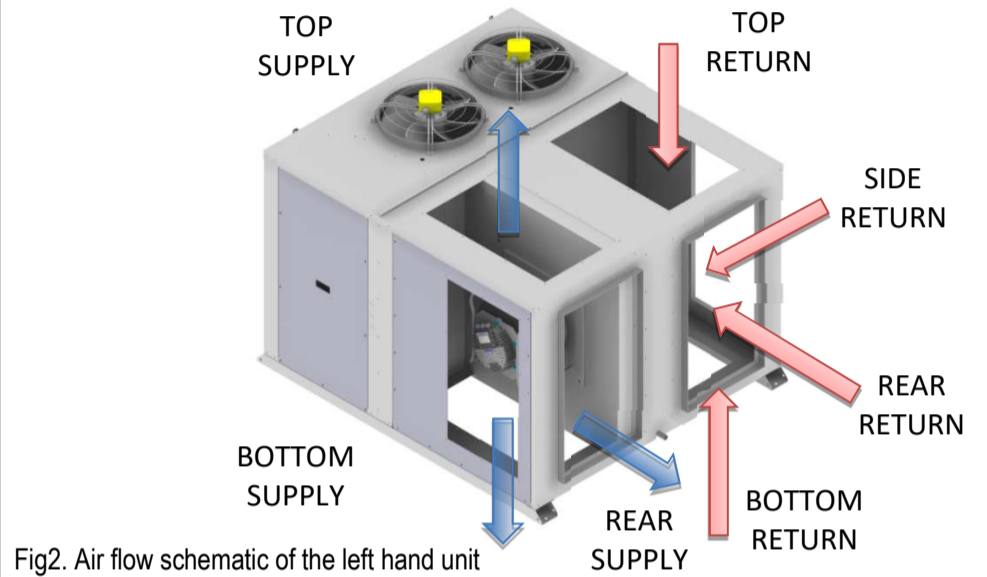

Fig2. Air flow schematic of the left hand unit

RIGHT HAND SUPPLY AIR APPLICABLE MODELS – P012-095AHR3SA

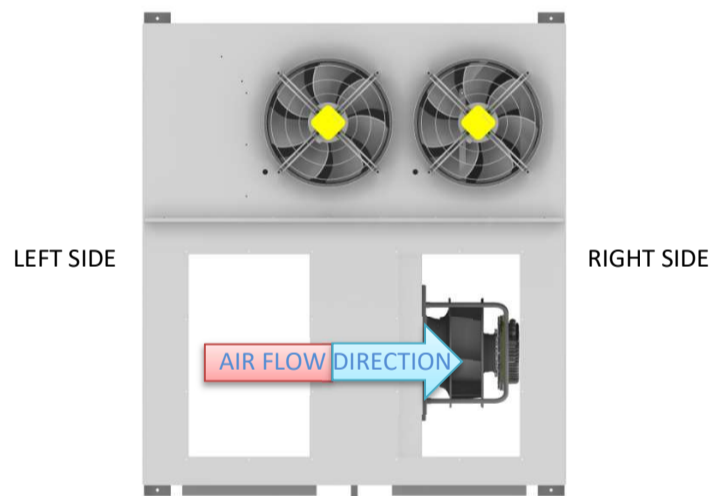

Fig3. Right hand unit top view

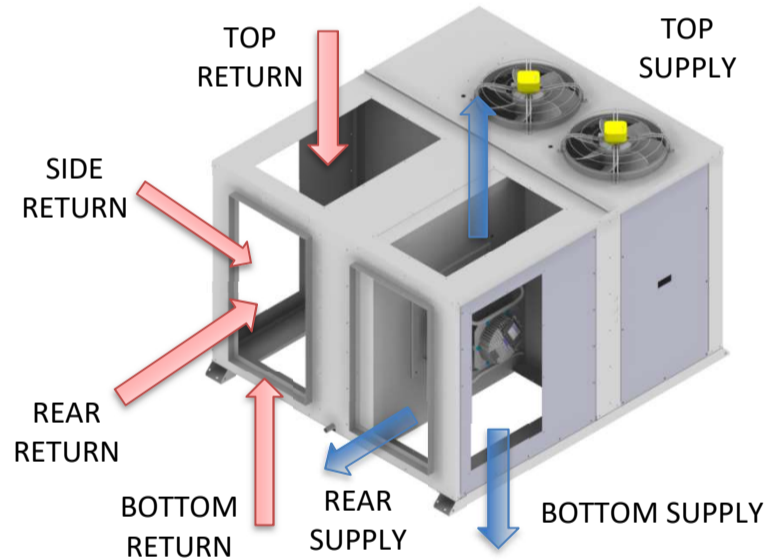

Fig 4. Air flow schematic of the right hand unit

CENTRED SUPPLY AIR APPLICABLE MODELS – P085-095AHR3SA OPTION – P115-170AHR3SA STANDARD

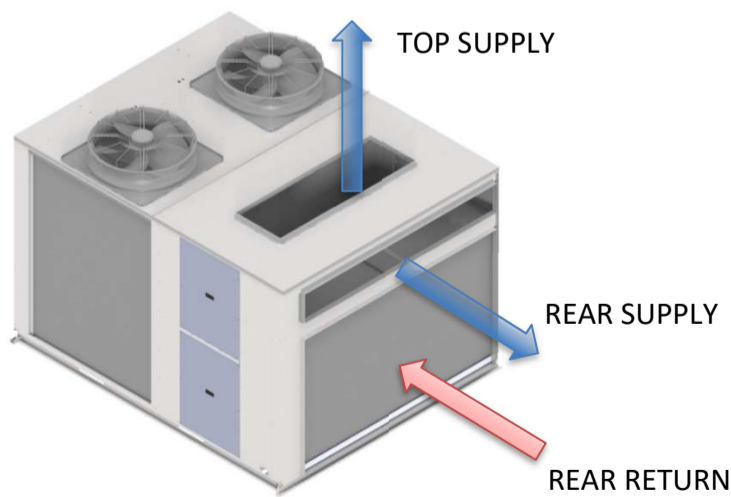

Fig5. Air flow schematic of the centred unit from above

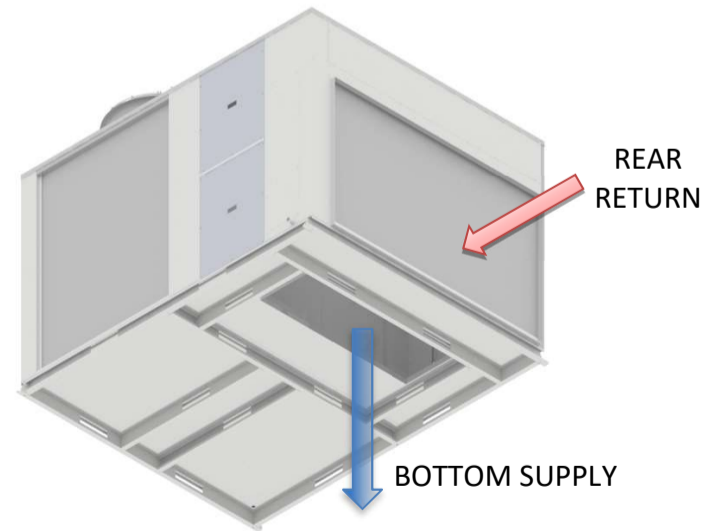

Fig6. Air flow schematic of the centred unit from below

CUSTOMER TO COMPLETE AND RETURN

CUSTOMER	PROJECT	UNIT REF	NAME / SIGN	DATE

NOTES:

1. GENERAL ARRANGEMENT OF A HORIZONTAL AIR COOLED PACKED UNIT
2. POWER AND FIELD CABLE ENTRIES THROUGH GLAND PLATE
3. ELECTRICAL ENCLOSURE AT FRONT OF MACHINE
4. CONDENSATE OUTLET Ø32x1 ON SIDE OF ENCLOSURE
5. UNIT BASE HAS Ø16x6 FIXING POINTS
6. UNIT HAS Ø12x4 LIFTING POINTS
7. UNIT CONFIGURATION AS STANDARD IS REAR SUPPLY, REAR RETURN, OTHER CONFIGURATIONS AVAILABLE
8. UNIT BASE HAS SLOTS FOR FORKLIFTING

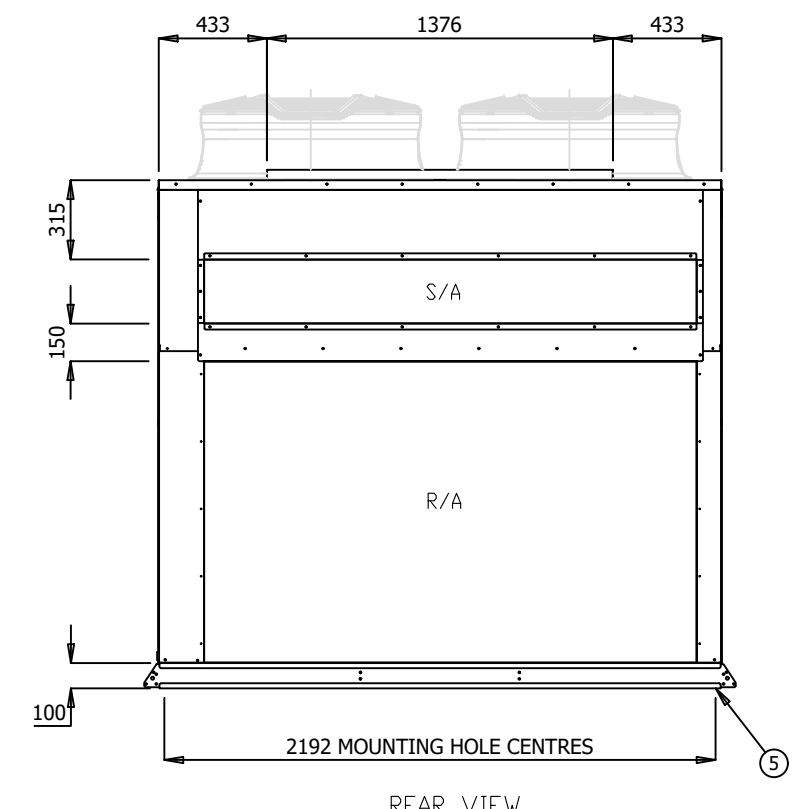
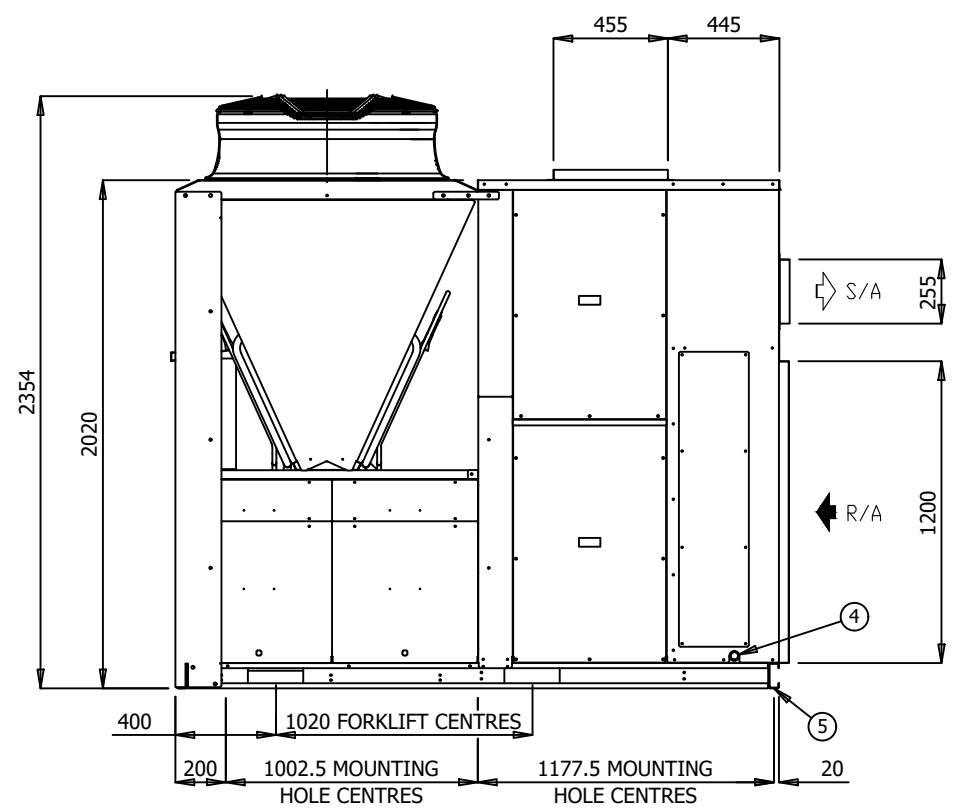
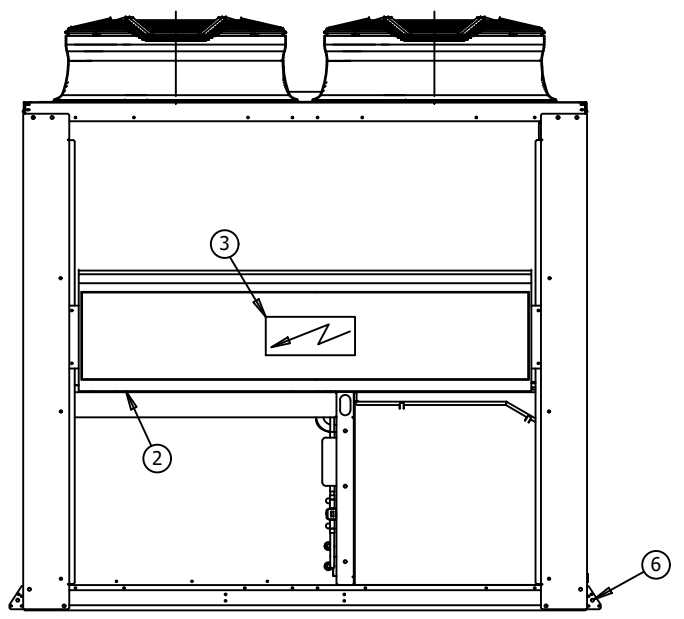
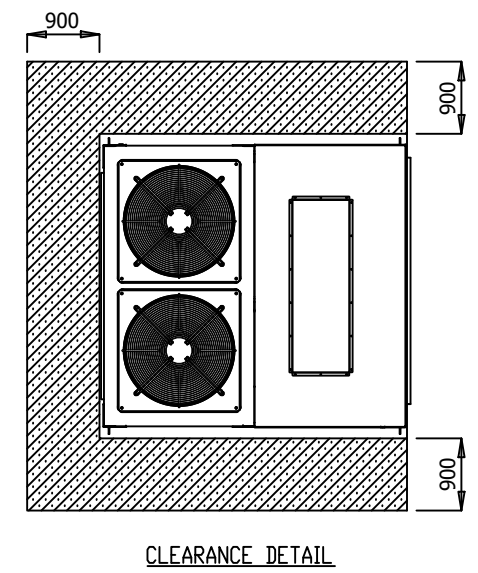
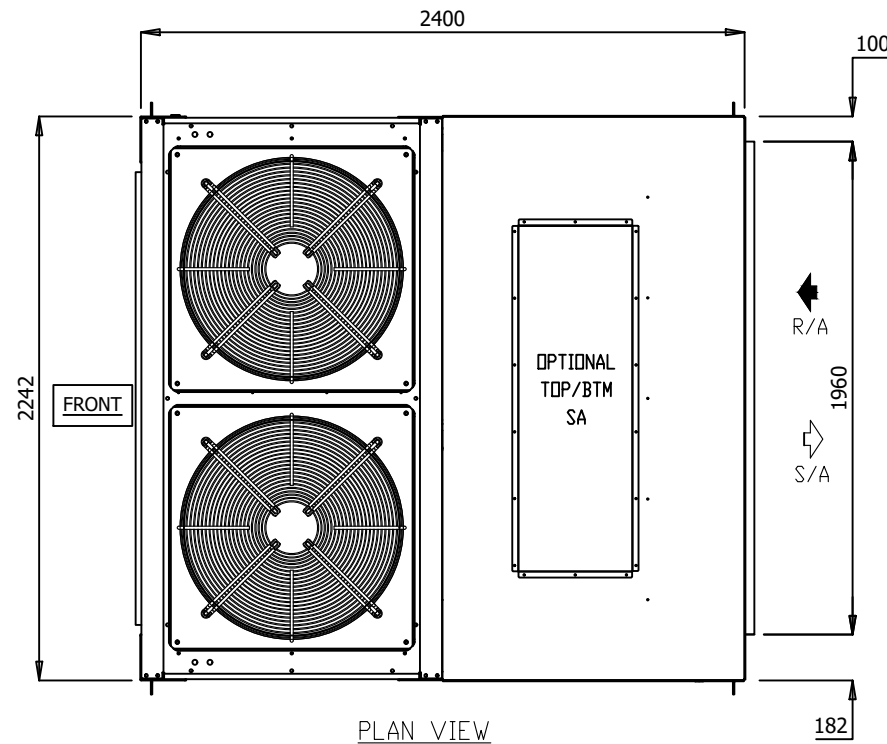

FRONT VIEW

RIGHT SIDE VIEW

REAR VIEW

- ALL DIMENSIONS IN mm.
- GENERAL TOLERANCE ±1mm.
- DO NOT SCALE DRAWING.
- MASTER DRAWINGS ARE HELD ELECTRONICALLY. ANY COPY IS DEEMED UNCONTROLLED AND THEREFORE NOT NECESSARILY THE LATEST REVISION.
- ALL INFORMATION REMAINS THE PROPERTY OF THE COMPANY.

GENERAL ARRANGEMENT

P115AHR3SA-

www.apacair.com.au

ABN: 74 005 138 769

REVISION	COMP COVERS ADDED, BASE MOUNTING POINTS UPDATED			
 ATLANTIC DR. KEYSBOROUGH VIC 3173 1300 555 545	DRAWN	HA	DRAWING No.	A4
	DATE	09.12.20	GAD0075	
	SCALE	N.T.S.		
	CHECKED	NJ	APP'D.	PC



TECHNICAL DATA SHEET

MODEL NUMBER		P115AHR3SA-	P150AHR3SA-	P170AHR3SA-	P200AHR3SA-	P230AHR3SA-	
CONDENSER SECTION	CAPACITY						
	Cooling	kW TOTAL*	111.44	149.51	167.17	199.35	222.89
		kW SENSIBLE*	91.16	121.25	136.74	161.67	182.32
		EER (kW / ikW)*	3.27	3.47	3.27	3.47	3.27
	Heating	kW TOTAL	109.10	144.28	163.64	192.37	218.19
		COP	4.00	4.01	4.00	4.01	4.00
	CAPACITY STEPS (%)		0/25/50/75/100	0/16.66/33.33/50/66.66/83.33/100	0/16.66/33.33/50/66.66/83.33/100	0/12.5/25/37.5/50/62.5/75/87.5/100	0/12.5/25/37.5/50/62.5/75/87.5/100
	CAPACITY STEPS (Qty)		4	6	6	8	8
	COMPRESSOR						
	TYPE		TANDEM SCROLL	TANDEM SCROLL	TANDEM SCROLL	TANDEM SCROLL	TANDEM SCROLL
	STARTER TYPE		D.O.L (Opt Soft/Start)	D.O.L (Opt Soft/Start)	D.O.L (Opt Soft/Start)	D.O.L (Opt Soft/Start)	D.O.L (Opt Soft/Start)
	PHASE		3∅	3∅	3∅	3∅	3∅
	No. OFF		2	3	3	4	4
	PROTECTION DEVICES						
	ALL COMPRESSORS HAVE						
	FAN						
	TYPE		EC AXIAL	EC AXIAL	EC AXIAL	EC AXIAL	EC AXIAL
	ikW (MAX INPUT)		1.95	1.95	1.95	1.95	1.95
	PHASE		3∅	3∅	3∅	3∅	3∅
	No. OFF		2	3	3	4	4
FAN SPEED CONTROL		VARIABLE SPEED	VARIABLE SPEED	VARIABLE SPEED	VARIABLE SPEED	VARIABLE SPEED	
HEAT EXCHANGER							
TYPE		PLATE FIN COIL	PLATE FIN COIL	PLATE FIN COIL	PLATE FIN COIL	PLATE FIN COIL	
NOM. AIRFLOW l/s		-	-	-	-	-	
REFRIGERANT SYSTEM							
TYPE							
CHARGE PER CIRCUIT (KG)		13.7	13.7	13.7	13.7	13.7	
No. OF CIRCUITS		2	3	3	4	4	
REFRIGERANT CONTROL		TXV					
ALL SYSTEMS INCLUDE							
EVAPORATOR SECTION	FAN						
	TYPE		EC PLUG	EC PLUG	EC PLUG	EC PLUG	EC PLUG
	ikW (MAX INPUT)		3.45	3.45	3.45	3.45	3.45
	PHASE		3∅	3∅	3∅	3∅	3∅
	No. OFF		2	3	3	4	4
	FAN SPEED CONTROL		VARIABLE SPEED	VARIABLE SPEED	VARIABLE SPEED	VARIABLE SPEED	VARIABLE SPEED
	HEAT EXCHANGER						
	TYPE		PLATE FIN COIL	PLATE FIN COIL	PLATE FIN COIL	PLATE FIN COIL	PLATE FIN COIL
	NOM. AIRFLOW l/s		5750	7500	8625	10000	11500
	EXT STATIC pa						
COMBINED SECTIONS	ELECTRICAL						
	MAINS POWER		415v / 3∅ / 50hz	415v / 3∅ / 50hz	415v / 3∅ / 50hz	415v / 3∅ / 50hz	415v / 3∅ / 50hz
	H.P. CUT OUT / IN kPa		4500 / 3450	4500 / 3450	4500 / 3450	4500 / 3450	4500 / 3450
	L.P. CUT OUT / IN kPa		175 / 345	175 / 345	175 / 345	175 / 345	175 / 345
	NOM. R.L.A. (TOTAL SYSTEM)		59.4	79.9	89.2	106.5	117.8
	MAX. F.L.A. (TOTAL SYSTEM)		100.4	127.8	150.6	170.4	200.8
	GENERAL						
	CABINET		GALVANISED SHEET STEEL				
	INSULATION		ALUMINIUM FOIL FACED POLYETHYLENE ACOUSTIC INSULATION				
	EXTERNAL FINISH		POLYESTER POWDER COAT - COLOUR LIGHT GREY AS STANDARD - OPTIONS AVAILABLE				
	DIMENSIONS						
	H X W X D (mm)		2354 x 2242 x 2400	2400 x 2242 x 3735	2400 x 2242 x 3735	2400 x 2242 x 4085	2400 x 2242 x 4085
	WEIGHT						
	OPERATING KG		1600	1800	2000	2200	2400
	SHIPPING KG		1610	1810	2010	2210	2410
NOISE LEVELS [Based on condenser fan's sound data]							
Sound Power db(A)		75.6	77.4	77.4	78.6	78.6	

Note: Rated in accordance with Australian standard AS/NZS 3823.1:2012
 Performance excludes ikW of evaporator fan motor.
 R.L.A - Run Load Amps are based on current drawn at nominal conditions
 F.L.A - Full Load Amps are based on the overload settings [Max Current] of all Compressor and Fan Motor(s).

Date	Document #	Approved By	Revision
2/4/20	TDS0035	PC	G

NOTE: Due to continuous improvement Rinnai Australia Pty Ltd reserve the right to change details without notice.

FAN PERFORMANCE CURVE

P115AHR3SA-

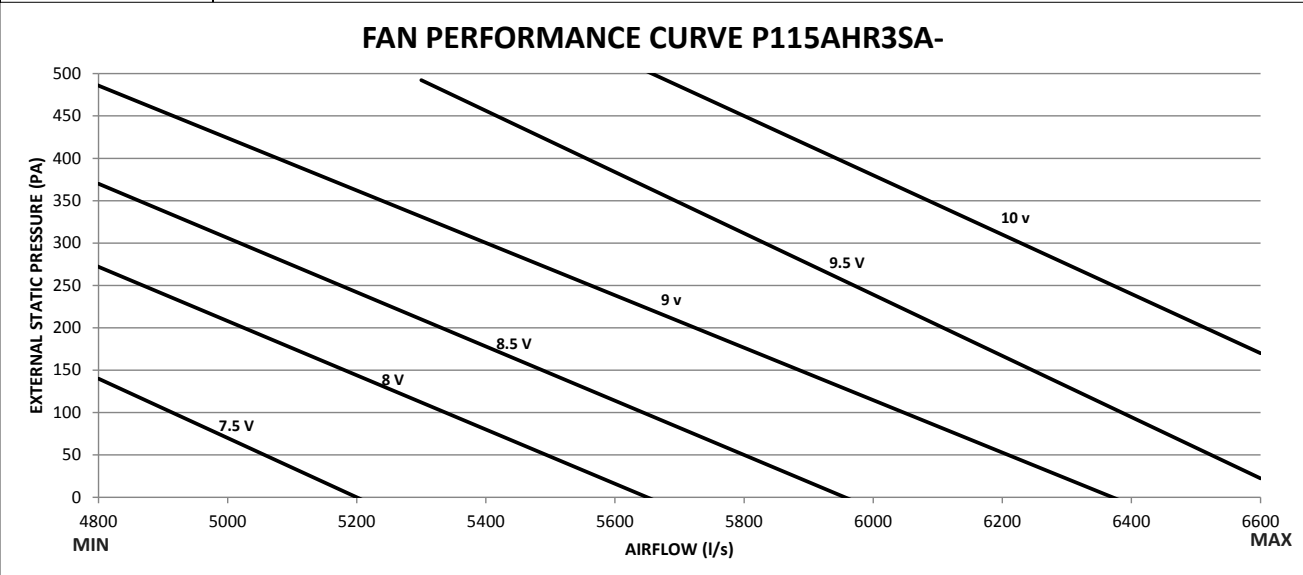

Note:

1. 7.5V, 8V, 8.5V, 9V, 9.5V and 10V represents potentiometer voltage. Potentiometer can be adjusted to achieve desired flowrates.
2. Potentiometer voltage can be varied infinitely between 0 to 10V.

Date	Document #	Approved By	Revision
29.05.18	FPC0058	CM	B

NOTE: Due to continuous improvement Rinnai Australia Pty Ltd reserve the right to change details without notice.



SOUND DATA

MODEL NUMBER

P115AHR3SA-

Outdoor Fan

Sound Power Level dB(A)	Octave band Centre Frequency (hz), dB						
	125	250	500	1k	2k	4k	8k
75.6	76.6	71.5	73.3	70	67	65.4	60

Indoor Fan

Sound Power Level dB(A)	Air Flow (l/s)	Octave band Centre Frequency (hz), dB						
		125	250	500	1k	2k	4k	8k
95.4	5670	79.7	86.4	89.6	90	89.6	86.5	83.3

Date	Document #	Approved By	Revision
03.06.18	SD0054	CM	B

NOTE: Due to continuous improvement Rinnai Australia Pty Ltd reserve the right to change details

