



SDU HORIZONTAL HANDING CONFIRMATION

<b>SO NUMBER</b> <small>(INTERNAL USE)</small>		<b>WO NUMBER</b> <small>(INTERNAL USE)</small>	
---	--	---	--

**SPLIT DUCTED UNITS (SDU IDH)**

<b>MODELS</b>	S024-095IHR3SA-
<b>GENERAL</b>	This document details the airside configurations available on 024-095 models.
<b>SOURCING</b>	Standard configuration is Front Supply /Rear Return. Optional airside configurations to be specified at time of order.
<b>HOW TO USE THIS DOCUMENT</b>	<ol style="list-style-type: none"> <li>1. Circle the required supply air outlet.</li> <li>2. Complete the information at the bottom of this document and return to your APAC representative.</li> </ol>

FS/RR – FRONT SUPPLY / REAR RETURN	TS/RR – TOP SUPPLY / REAR RETURN
------------------------------------	----------------------------------

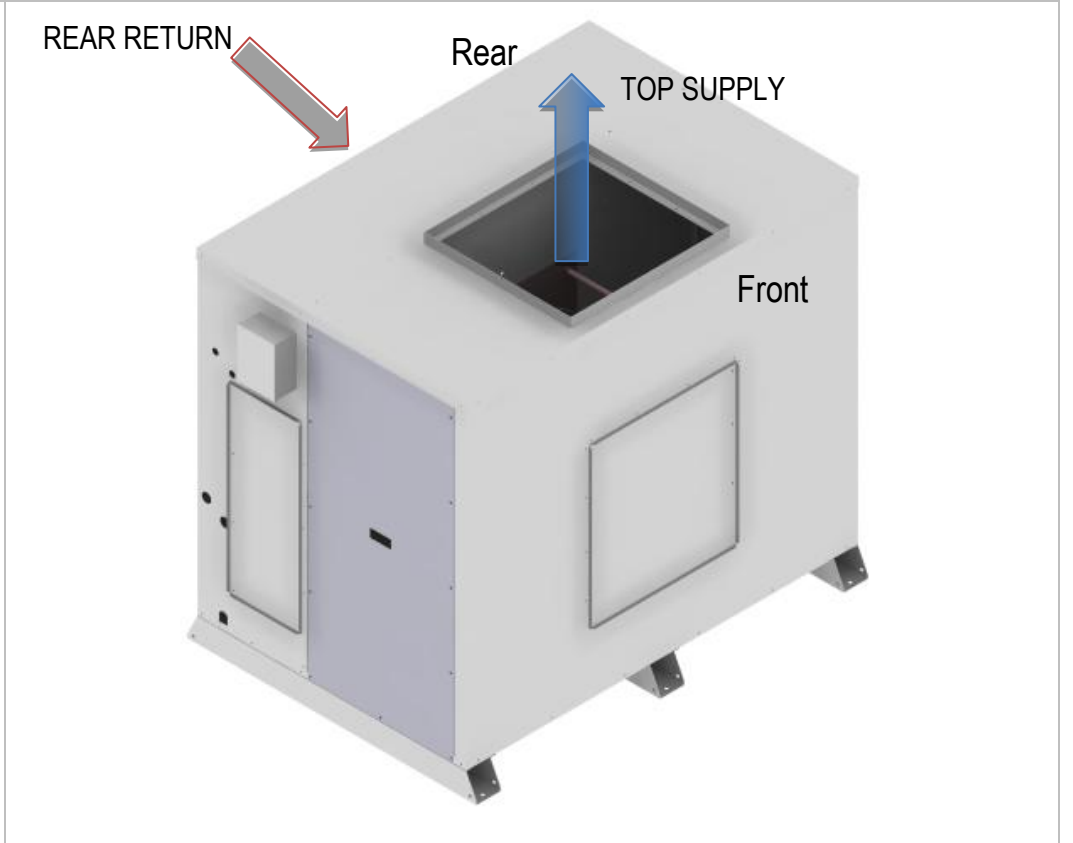
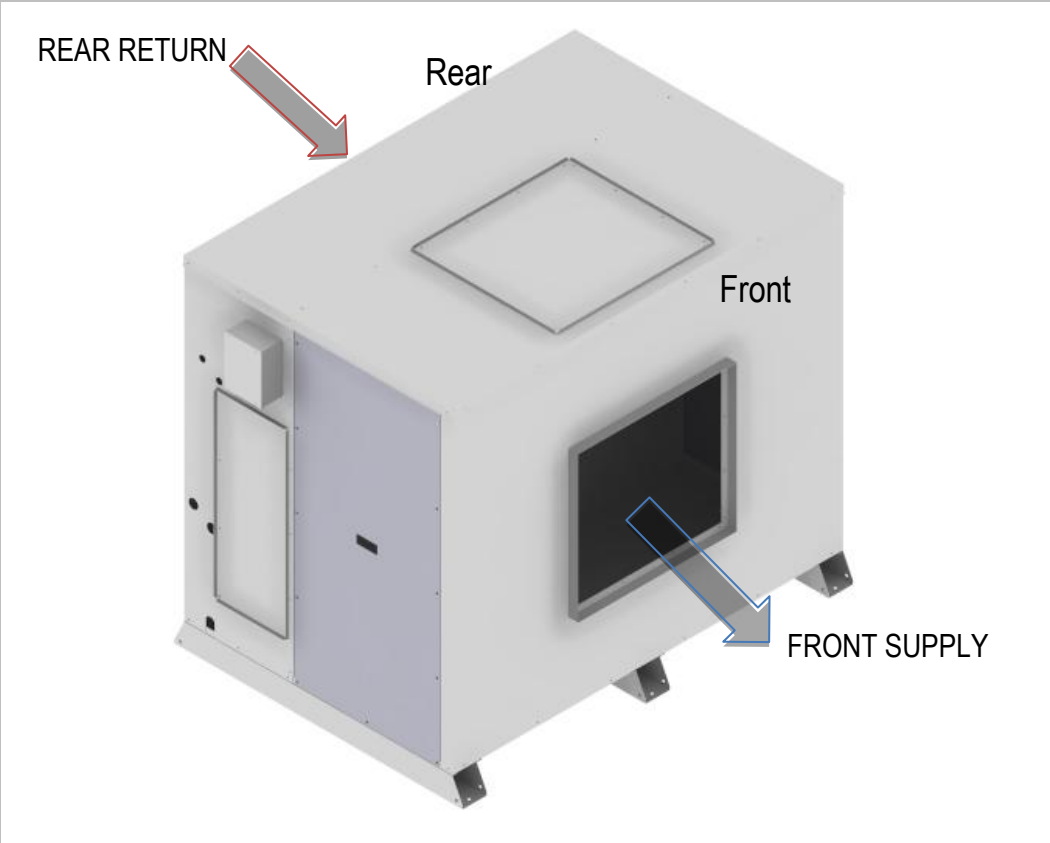

**CUSTOMER TO COMPLETE AND RETURN**

CUSTOMER	PROJECT	UNIT REF	NAME / SIGN	DATE

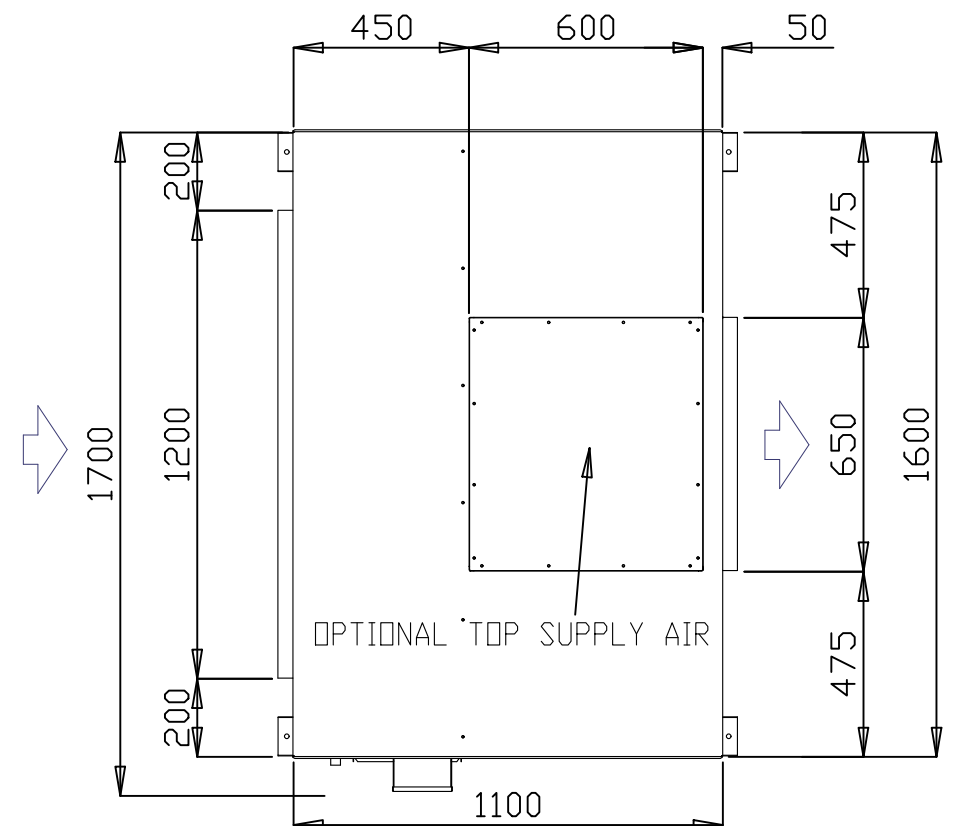

PLAN

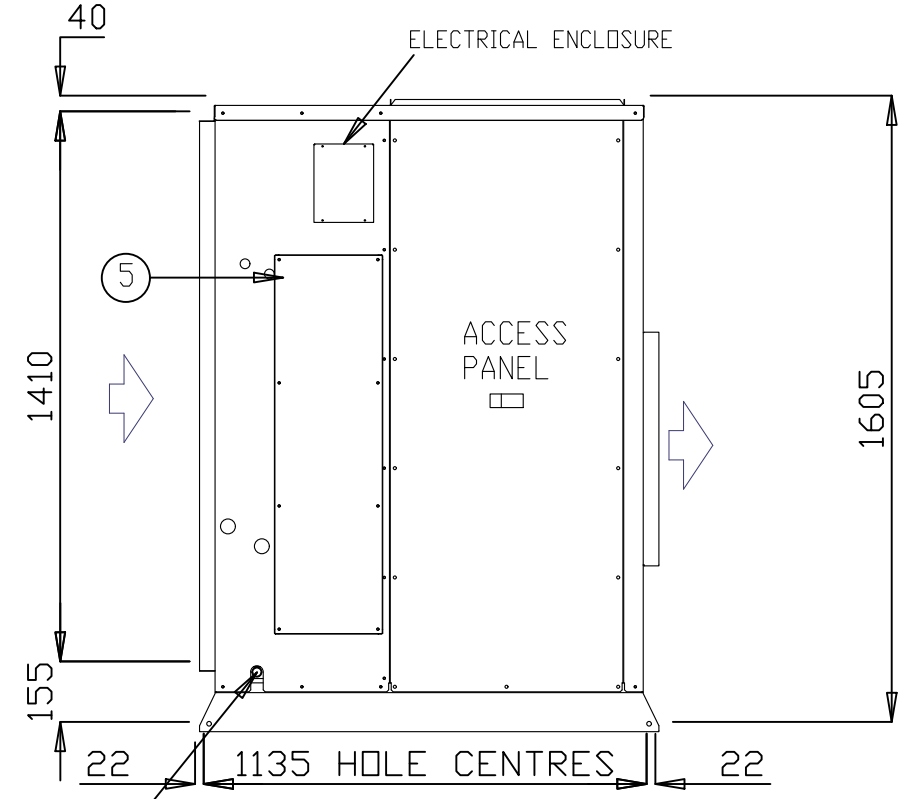

ELEVATION

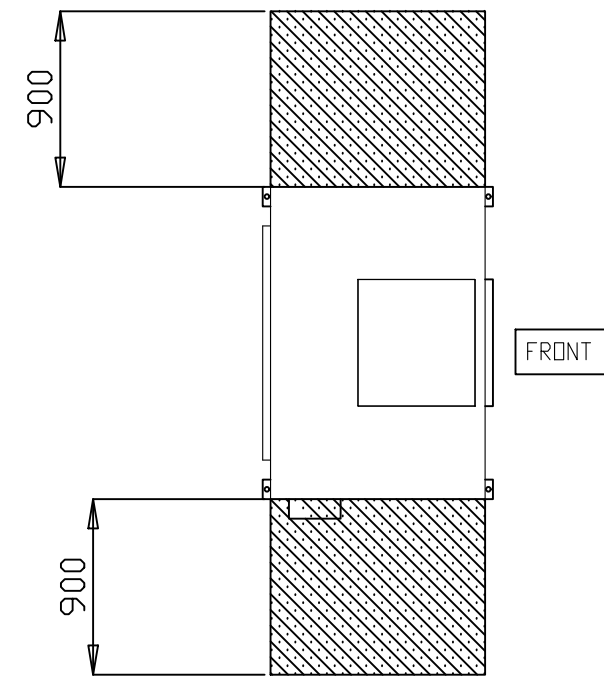

CLEARANCE DETAIL

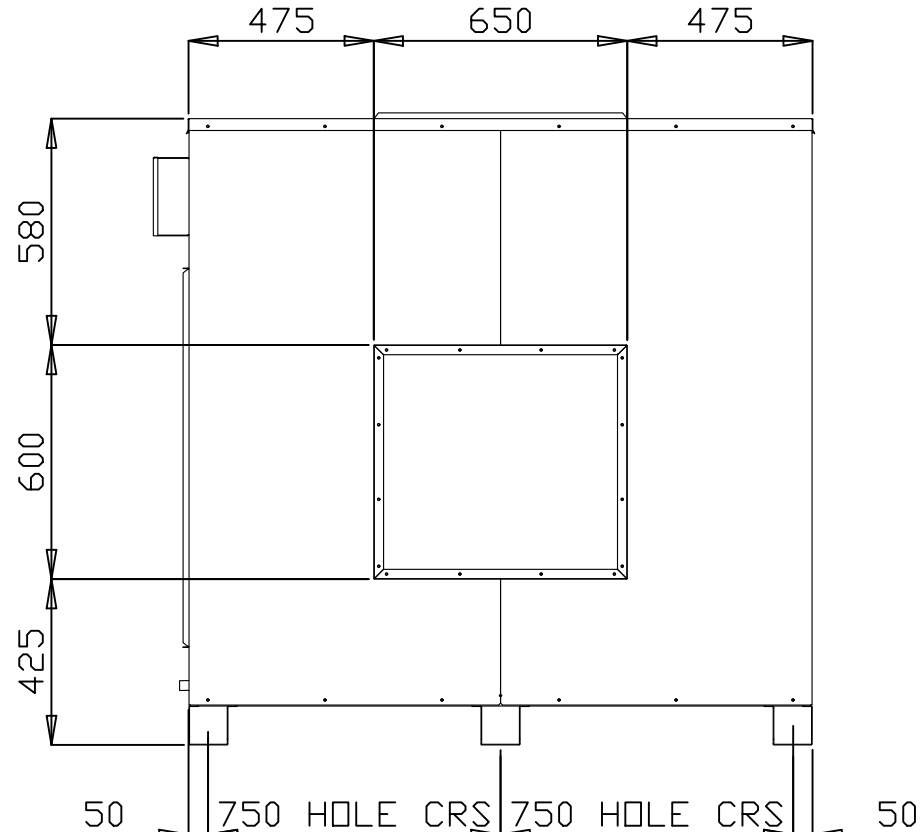

FRONT ELEVATION

NOTES :

1. DRAWING REFLECTS A HORIZONTAL FAN COIL UNIT
2. GAS, DRAIN & ELECTRICAL CONNECTIONS ON SAME SIDE
3. ELECTRICAL CABLE ENTRY 25mm $\phi$
4. CONDENSATE DRAIN OUTLET 25.4mm $\phi$
5. ACCESS DOORS ON BOTH SIDES
6. OPTIONAL TOP SUPPLY CONFIGURABLE ON SITE
7. REFER TO OPERATIONAL AND MAINTENANCE MANUAL FOR PIPE SIZING

- ALL DIMENSIONS IN mm.
- GENERAL TOLERANCE  $\pm 1$ mm.
- DO NOT SCALE DRAWING.
- MASTER DRAWINGS ARE HELD ELECTRONICALLY. ANY COPY IS DEEMED UNCONTROLLED AND THEREFORE NOT NECESSARILY THE LATEST REVISION.
- ALL INFORMATION REMAINS THE PROPERTY OF THE COMPANY.

GENERAL ARRANGEMENT

S065IHR3SA- S075IHR3SA-

www.apacair.com.au

ABN: 74 005 138 769

	REVISION					REVISED NAMEPLATE WITH APAC DETAILS				
	DRAWN		MT	DRAWING No.		A4				
	DATE		24.03.14	GAD0017						
	SCALE		N.T.S.							
CHECKED		HA	APP'D.	CM	REV.	E				

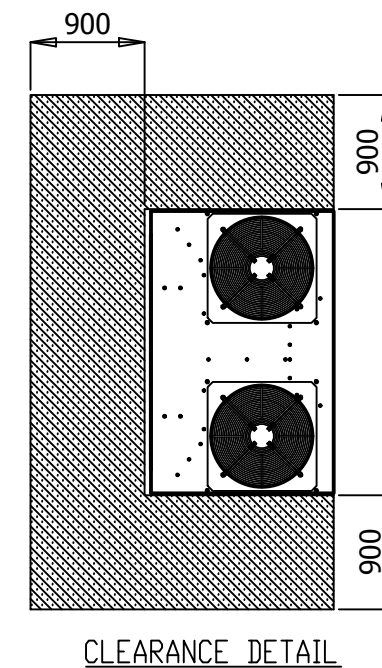
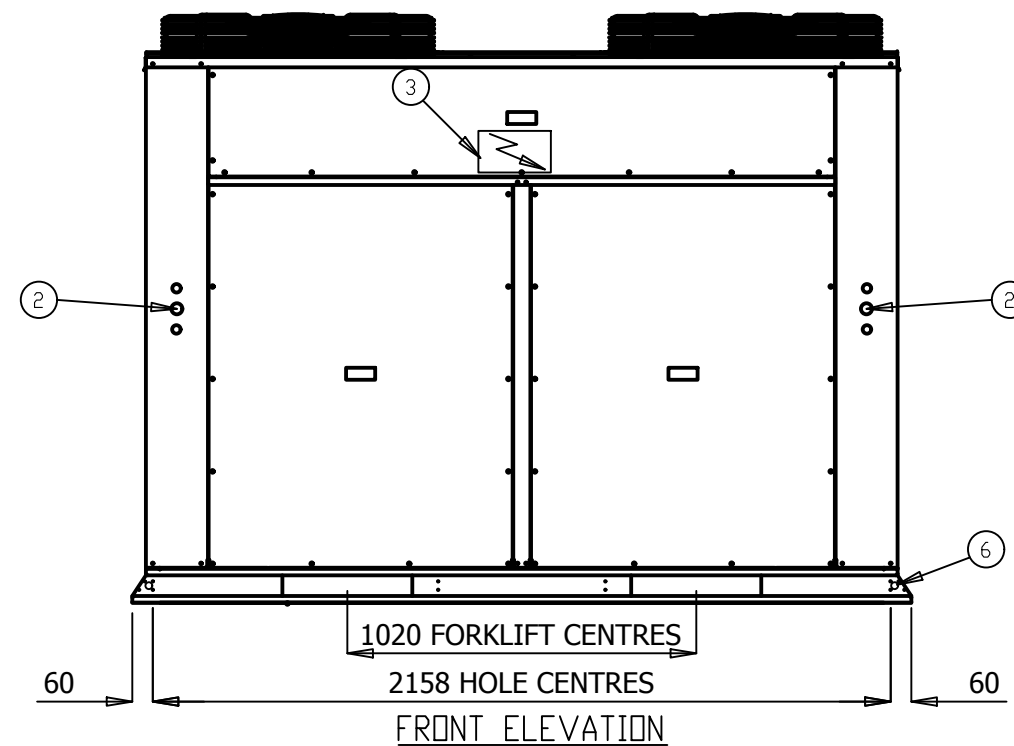
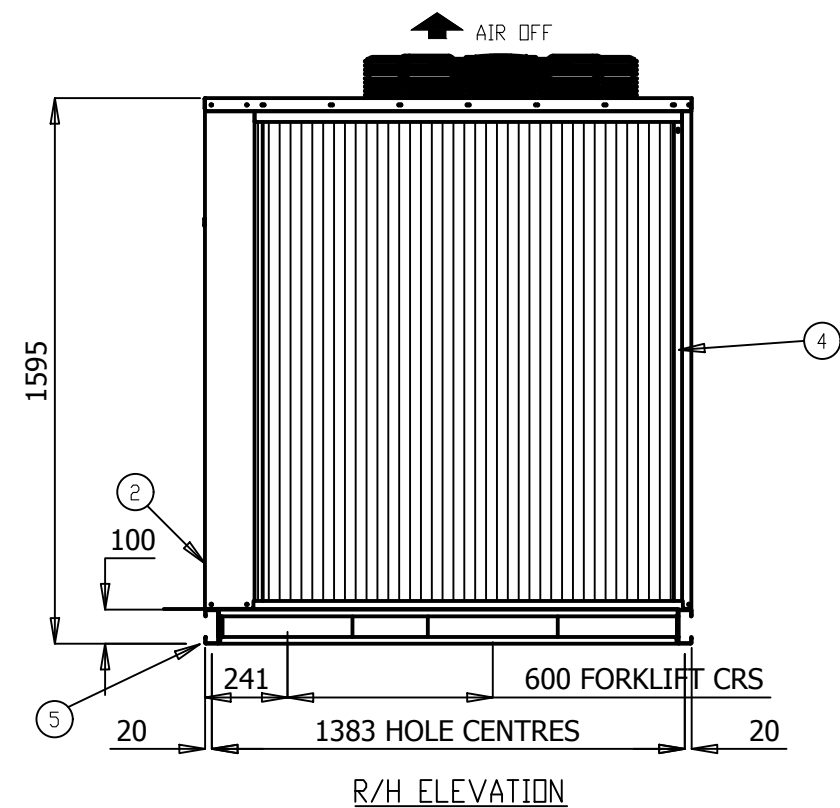
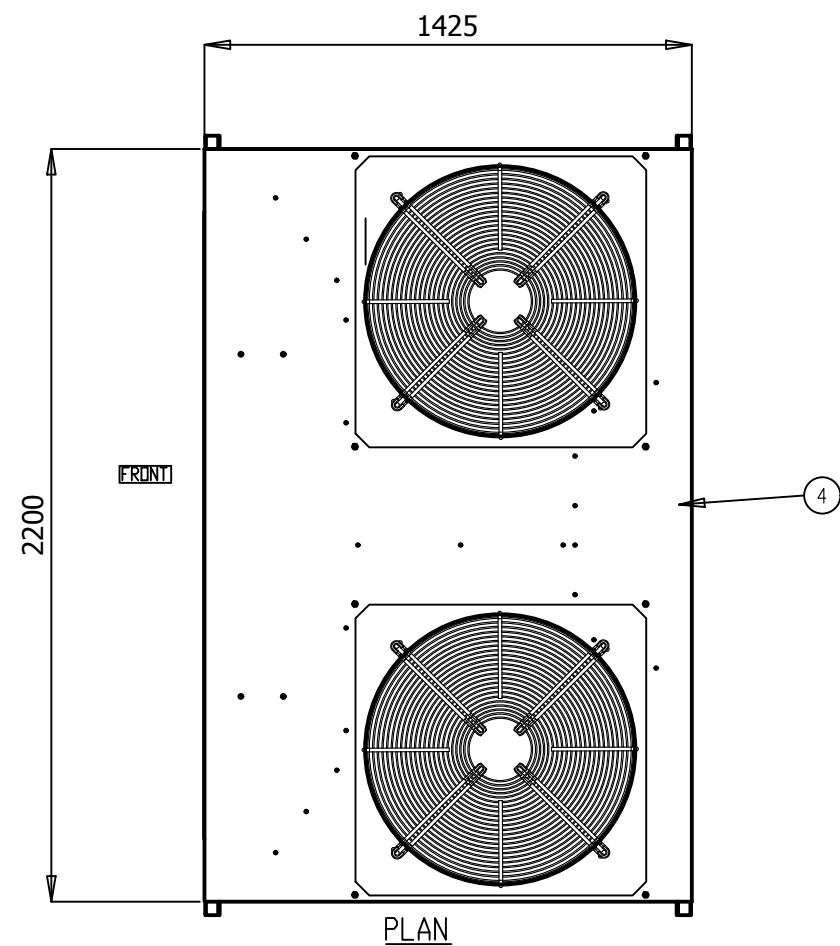

- NOTES:
1. GENERAL ARRANGEMENT OF A OUTDOOR SPLIT AIR COOLED VERTICAL UNIT
  2. POWER AND FIELD CABLE ENTRIES, 1 x 32 $\phi$  AND 2 x 25 $\phi$
  3. ELECTRICAL PANEL LOCATED BEHIND SERVICE ACCESS
  4. FIELD PIPE CONNECTIONS
  5. UNIT BASE 4 x 16 $\phi$  FIXING POINTS
  6. UNIT HAS 4 x 20 $\phi$  LIFTING POINTS
  7. REFER TO INSTALLATION AND OPERATIONAL MANUAL FOR PIPE SIZING

- ALL DIMENSIONS IN mm.
- GENERAL TOLERANCE  $\pm 1$ mm.
- DO NOT SCALE DRAWING.
- MASTER DRAWINGS ARE HELD ELECTRONICALLY. ANY COPY IS DEEMED UNCONTROLLED AND THEREFORE NOT NECESSARILY THE LATEST REVISION.
- ALL INFORMATION REMAINS THE PROPERTY OF THE COMPANY.

## GENERAL ARRANGEMENT

S0650VR3SA- S0750VR3SA-

www.apacair.com.au

ABN: 74 005 138 769

REVISION	REVISED NAMEPLATE WITH APAC DETAILS				
		DRAWN	MT	DRAWING No.	A4
	ATLANTIC DR. KEYSBOROUGH VIC 3173 1300 555 545	DATE	19.05.14	<b>GAD0019</b>	
	SCALE	N.T.S.			
	CHECKED	HA	APP'D.	CM	REV.

# TECHNICAL DATA SHEET

MODEL NUMBER	Indoor	S055IHR3SA-	S065IHR3SA-	S075IHR3SA-	S085IHR3SA-	S095IHR3SA-	
	Outdoor	S055OVR3SA-	S065OVR3SA-	S075OVR3SA-	S085OVR3SA-	S095OVR3SA-	
MEPS REGISTRATION NUMBER		AAC3221	AAC3233	N/A	N/A	N/A	
<b>OUTDOOR SECTION</b>	<b>CAPACITY</b>						
	<b>Cooling</b>	kW TOTAL*	52.90	63.88	72.95	83.74	94.04
		kW SENSIBLE*	44.01	54.50	58.50	69.34	77.49
		EER (kW / ikW)*	3.07	3.28	3.49	3.47	3.24
	<b>Heating</b>	kW TOTAL	54.30	65.00	73.40	84.30	96.10
		COP	3.39	3.61	3.59	3.60	3.60
	CAPACITY STEPS (%)		50/100	50/100	50/100	50/100	50/100
	<b>COMPRESSOR</b>						
	TYPE		SCROLL	SCROLL	SCROLL	SCROLL	SCROLL
	STARTER TYPE		D.O.L (Opt Soft/Start)	D.O.L (Opt Soft/Start)	D.O.L (Opt Soft/Start)	D.O.L (Opt Soft/Start)	D.O.L (Opt Soft/Start)
	PHASE		3∅	3∅	3∅	3∅	3∅
	No. OFF		2	2	2	2	2
	PROTECTION DEVICES HP SWITCH, LP SWITCH, MOTOR OVERLOAD'S						
	ALL COMPRESSORS HAVE SUMP HEATER						
	<b>FAN</b>						
	TYPE		EC AXIAL	EC AXIAL	EC AXIAL	EC AXIAL	EC AXIAL
	ikW (MAX INPUT)		0.97	0.93	0.93	0.93	0.93
	PHASE		3∅	3∅	3∅	3∅	3∅
	No. OFF		2	2	2	2	2
	FAN SPEED CONTROL		VARIABLE SPEED	VARIABLE SPEED	VARIABLE SPEED	VARIABLE SPEED	VARIABLE SPEED
	<b>HEAT EXCHANGER</b>						
	TYPE		PLATE FIN COIL	PLATE FIN COIL	PLATE FIN COIL	PLATE FIN COIL	PLATE FIN COIL
	NOM. AIRFLOW l/s		-	-	-	-	-
	<b>REFRIGERANT SYSTEM</b>						
	TYPE		<b>R410A</b>				
FACTORY CHARGE PER CIRCUIT (KG)		5.75	6.75	9.5	11	10.8	
No. OF CIRCUITS		2	2	2	2	2	
REFRIGERANT CONTROL		TXV					
ALL SYSTEMS INCLUDE FILTER DRIERS							
<b>DIMENSIONS</b>							
H X W X D (mm)		1390 x 1850 x 1426	1595 x 2200 x 1425	1800 x 2200 x 1425			
<b>WEIGHT</b>							
OPERATING KG		510	600	610	761	783	
SHIPPING KG		515	605	615	766	788	
<b>ELECTRICAL</b>							
POWER SUPPLY		415v / 3∅ / 50hz					
RLA / FLA (Amps)		28.6/45.2	32.7/47	35.3/53	40.2/65	52.2/71	
<b>INDOOR SECTION</b>	<b>FAN</b>						
	TYPE		EC PLUG	EC PLUG	EC PLUG	EC PLUG	EC PLUG
	ikW (MAX INPUT)		3	2.73	2.73	2.82	2.82
	PHASE		3∅	3∅	3∅	3∅	3∅
	No. OFF		1	2	2	2	2
	FAN SPEED CONTROL		VARIABLE SPEED	VARIABLE SPEED	VARIABLE SPEED	VARIABLE SPEED	VARIABLE SPEED
	<b>HEAT EXCHANGER</b>						
	TYPE		PLATE FIN COIL	PLATE FIN COIL	PLATE FIN COIL	PLATE FIN COIL	PLATE FIN COIL
	NOM. AIRFLOW l/s		2880	3550	3750	4400	4930
	EXT STATIC pa		100				
	<b>DIMENSIONS</b>						
	H X W X D (mm)		1400 x 1600 x 1100	1605 x 1600 x 1100	1805 x 1850 x 1100		
	<b>WEIGHT</b>						
	OPERATING KG		290	340	340	461	461
	SHIPPING KG		295	345	345	466	466
<b>ELECTRICAL</b>							
POWER SUPPLY		415v / 3∅ / 50hz					
RLA / FLA (Amps)		2.5/4.6	2.2/8.4	2.8/8.4	3.3/8.6	4.1/8.6	
<b>COMBINED SECTIONS</b>	<b>ELECTRICAL</b>						
	H.P. CUT OUT / IN kPa		4500 / 3450	4500 / 3450	4500 / 3450	4500 / 3450	4500 / 3450
	L.P. CUT OUT / IN kPa		175 / 345	175 / 345	175 / 345	175 / 345	175 / 345
	NOM. R.L.A. (TOTAL SYSTEM)		31.1	34.9	38.1	43.5	56.3
	MAX. F.L.A. (TOTAL SYSTEM)		49.8	55.4	61.4	73.6	79.6
	<b>GENERAL</b>						
	CABINET GALVANISED SHEET STEEL						
	INSULATION ALUMINIUM FOIL FACED POLYETHYLENE ACOUSTIC INSULATION						
	EXTERNAL FINISH POLYESTER POWDER COAT - COLOUR LIGHT GREY AS STANDARD - OPTIONS AVAILABLE						
	<b>INDOOR AND OUTDOOR PIPE CONNECTION</b>						
LIQUID mm (inch)		12.7 (1/2")	12.7 (1/2")	12.7 (1/2")	15.9 (5/8")	15.9 (5/8")	
GAS mm (inch)		28.6 (1-1/8")	28.6 (1-1/8")	28.6 (1-1/8")	28.6 (1-1/8")	28.6 (1-1/8")	
<b>ADDITIONAL REFRIGERATION CHARGE AND FIELD PIPING CONNECTIONS</b>							
REFER TO INSTALLATION AND OPERATION MANUAL							
<b>NOISE LEVELS</b> [Based on condenser fan's sound data]							
SOUND POWER db(A)		70.9	71.5	71.5	71.5	71.5	

Note:

\*Performance excludes ikW of evaporator fan motor.

R.L.A - Run Load Amps are based on current drawn at nominal conditions

F.L.A - Full Load Amps are based on the overload settings [Max Current] of all Compressor and Fan Motor(s).

This TDS is also applicable to models: ASCE055HA3A-ASCC055VA3A; ASCE065HA3A-ASCC065VA3A; ASCE075HA3A-ASCC075VA3A; ASCE085HA3A-ASCC085VA3A; ASCE095HA3A-ASCC095VA3A.

Date	Document #	Approved By	Revision
1/6/18	TDS0023	CM	D

**NOTE: Due to continuous improvement Rinnai Australia Pty Ltd reserve the right to change details without notice.**

## FAN PERFORMANCE CURVE

**S065IHR3SA-**

**FAN PERFORMANCE CURVE S065IHR3SA-**

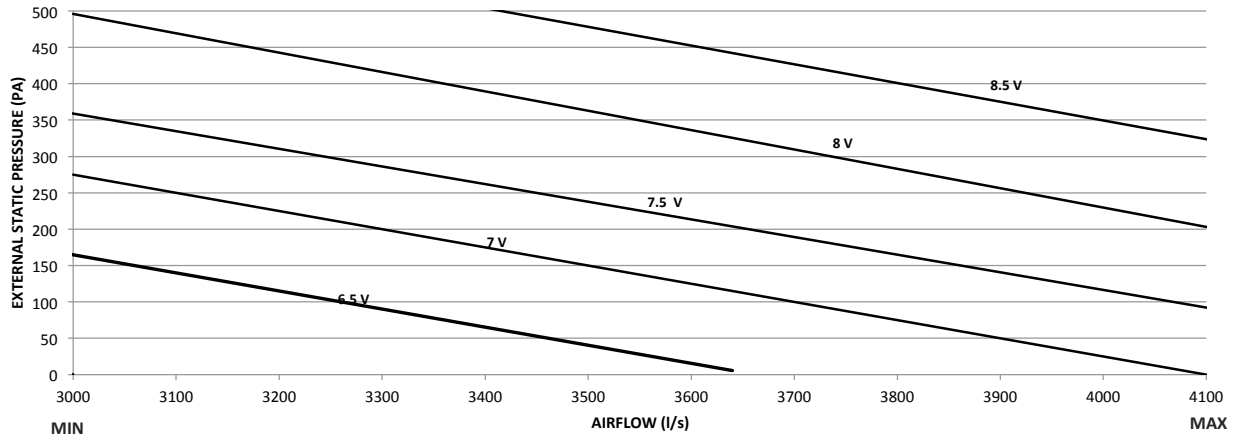

Note:

1. 5.5V, 6.5V, 7V, 7.5V, 8V and 8.5V represents potentiometer voltage. Potentiometer can be adjusted to achieve desired flowrates.
2. Potentiometer voltage can be varied infinitely between 0 to 10V.

Date	Document #	Approved By	Revision
29.05.18	FPC0039	CM	B

**NOTE: Due to continuous improvement Rinnai Australia Pty Ltd reserve the right to change details without notice.**



## **SOUND DATA**

**MODEL NUMBER**

**S065IHR3SA- / S065OVR3SA-**

### **Outdoor Fan**

Sound Power Level dB(A)	Octave band Centre Frequency (Hz), dB						
	125	250	500	1k	2k	4k	8k
71.5	73.9	68.9	66.5	64.6	65.7	62	58.4

### **Indoor Fan**

Sound Power Level dB(A)	Air Flow (l/s)	Octave band Centre Frequency (Hz), dB						
		125	250	500	1k	2k	4k	8k
82.8	3550	68.4	77.9	80.8	81.6	77.3	77	76.4

Date	Document #	Approved By	Revision
01.06.18	SD0025	CM	B

**NOTE: Due to continuous improvement Rinnai Australia Pty Ltd reserve the right to change details**

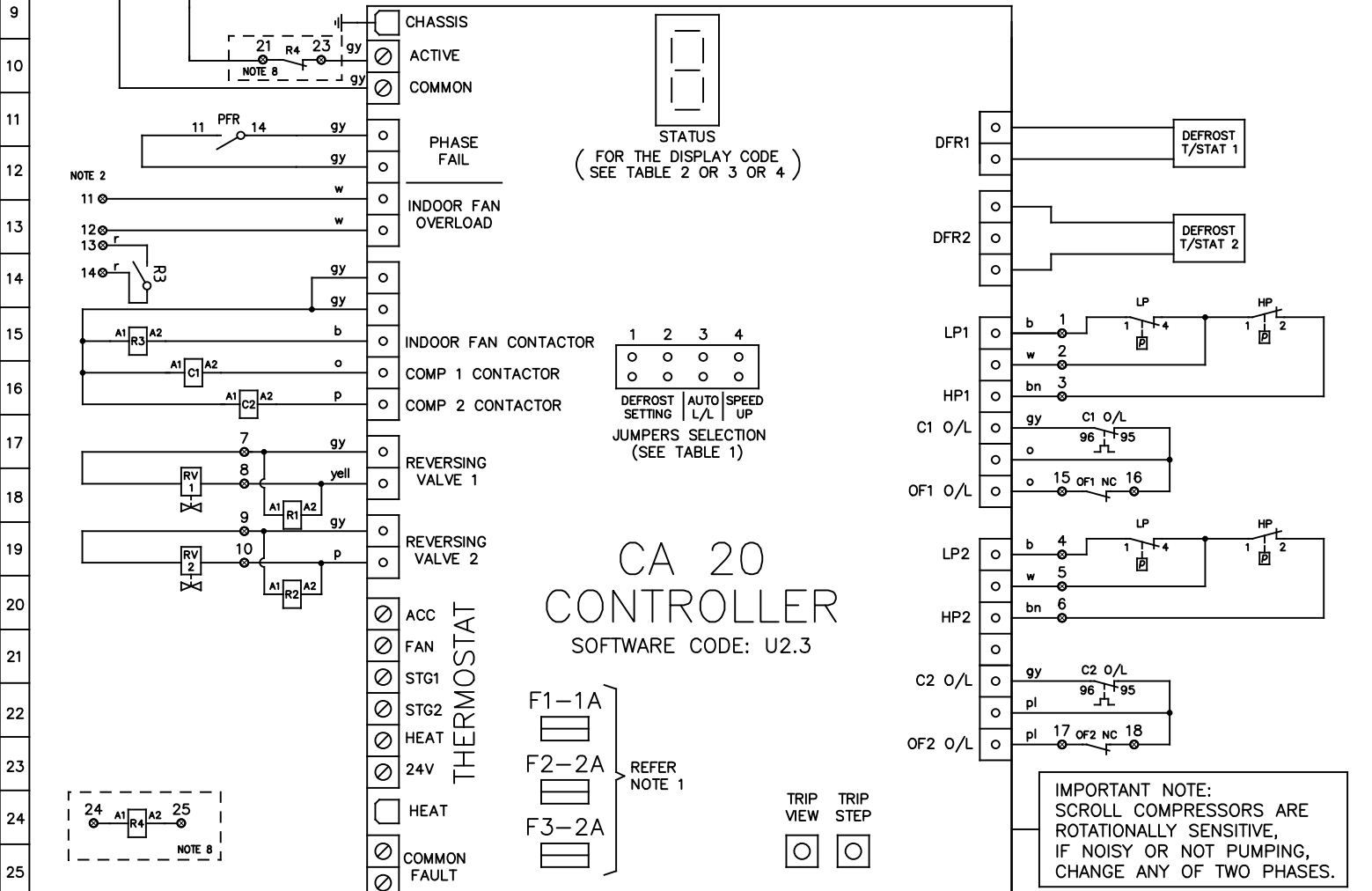
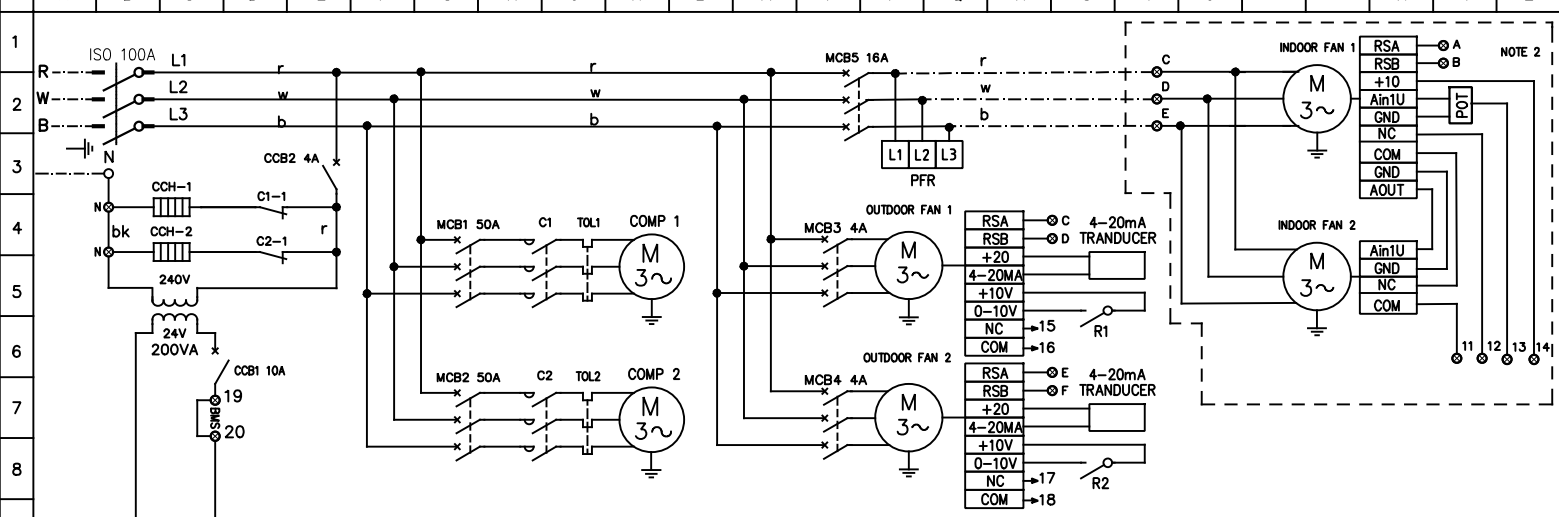

# CA 20 CONTROLLER

SOFTWARE CODE: U2.3

**IMPORTANT NOTE:**  
SCROLL COMPRESSORS ARE ROTATIONALLY SENSITIVE, IF NOISY OR NOT PUMPING, CHANGE ANY OF TWO PHASES.

**WARNING!** THE SOFTWARE OF THE CA20 CONTROLLER IS NOT DESIGNED TO FUNCTION AS A PRIMARY PERSONAL SAFETY DEVICE, AS CONNECTED EQUIPMENT CAN START AUTOMATICALLY WITHOUT WARNING. ALSO, OPENING THERMOSTAT CONTACTS MAY NOT CAUSE THE EQUIPMENT TO STOP. OUTDOOR FAN MOTORS HAVE INTERNAL OVERLOADS AND MAY RESTART AUTOMATICALLY.

- NOTES:**
- TIME DELAY GLASS FUSES ON THE PCB CONTROLLER ARE THE FOLLOWING:
    - F1 PROTECTS THE THERMOSTAT CIRCUIT.
    - F2 PROTECTS THE REVERSING VALVE CIRCUITS AND THE "HEAT" OUTPUT. THIS FUSE F2 ALSO SUPPLIES FUSE F1.
    - F3 PROTECTS BOTH COMPRESSOR CONTACTOR CIRCUITS AND THE INDOOR FAN CONTACTOR CIRCUIT.
  - FOR SPLIT SYSTEMS. OTHERS TO INSTALL ISOLATOR AND FIELD WIRING
  - HP CUT OUT , LP CUT OUT - AUTO RESET.
  - THERMAL OVERLOAD RELAYS - AUTO RESET, UNLESS OTHERWISE STATED.
  - DO NOT CONNECT ANY ADDITIONAL EQUIPMENT TO THE CONTROL TRANSFORMER OTHER THAN THE EQUIPMENT SHOWN ON THE ELECTRICAL DRAWING.
  - ALL FIELD WIRING IS THE RESPONSIBILITY OF THE INSTALLING CONTRACTOR AND MUST COMPLY WITH AS/NZS 3000 AND LOCAL RULES.
  - SOFTWARE CODE MUST BE CHECKED AFTER REPLACEMENT OF THE CA-20 CONTROLLER BY CHECKING THE DISPLAY CODE ON THE 7 SEGMENT DISPLAY AFTER THE CONTROLLER IS ACTIVATED.
  - OPTIONAL FIRE ALARM RELAY

JUMPERS SELECTION	DEFROST INTERVAL TIME SETTING	JUMPERS SELECTION	AUTO LEAD/LAG	JUMPERS SELECTION	SPEED UP
1 2 ○ ○	15 min	3 ○	OFF	4 ○	OFF
1 2 ● ○	FACTORY SETTING 30 min	3 ●	ON	4 ●	ON
1 2 ● ●	45 min	3 ●	ON	4 ●	ON

UNIT MUST BE SWITCHED OFF BEFORE CHANGING THE JUMPER SELECTION

LEGEND		LEGEND		COLOUR CODE		COMPRESSOR (EACH)		MODEL: S0650VR3SA-H	
○	TERMINAL SWITCHBOARD	TOL	THERMAL OVERLOAD RELAY	r	RED	KW		OPTIONS	
⊗	TERMINAL	R	RELAY	w	WHITE	7.83		DESCRIPTION	
- - -	FIELD WIRING	C	CONTACTOR	b	BLUE	RATED CURRENT		STANDARD	
- - -	CONTROL PARAMETER	COMP	COMPRESSOR	bk	BLACK	22.00		REF	
○	MAINS/CONTROL WIRING	ISO	ISOLATOR SWITCH	bn	BROWN	O/L SETTING		A	
○		MCB	MINIATURE CIRCUIT BREAKER	o	ORANGE	24.20			
CCH	CRANK CASE HEATER	CCB	CONTROL CIRCUIT BREAKER	p	PINK	FANS (EACH)	KW	FLA	
PFR	PHASE FAILURE RELAY	POT	POTENTIOMETER	pl	PURPLE	OUTDOOR	0.93	1.50	
RV	REVERSING VALVE			gy	GREY	INDOOR	2.73	4.20	
HP	HIGH PRESSURE SWITCH			yell	YELLOW				
LP	LOW PRESSURE SWITCH								

DATE: 24/06/2018  
 DWN: S.P    APPD: ENG  
 REV: A    GRID: B176  
 DWG No: EWS02157