



SDU HORIZONTAL HANDING CONFIRMATION

SO NUMBER (INTERNAL USE)		WO NUMBER (INTERNAL USE)	
------------------------------------	--	------------------------------------	--

SPLIT DUCTED UNITS (SDU IDH)

MODELS	S024-095IHR3SA-
GENERAL	This document details the airside configurations available on 024-095 models.
SOURCING	Standard configuration is Front Supply /Rear Return. Optional airside configurations to be specified at time of order.
HOW TO USE THIS DOCUMENT	<ol style="list-style-type: none"> 1. Circle the required supply air outlet. 2. Complete the information at the bottom of this document and return to your APAC representative.

FS/RR – FRONT SUPPLY / REAR RETURN	TS/RR – TOP SUPPLY / REAR RETURN
---	---

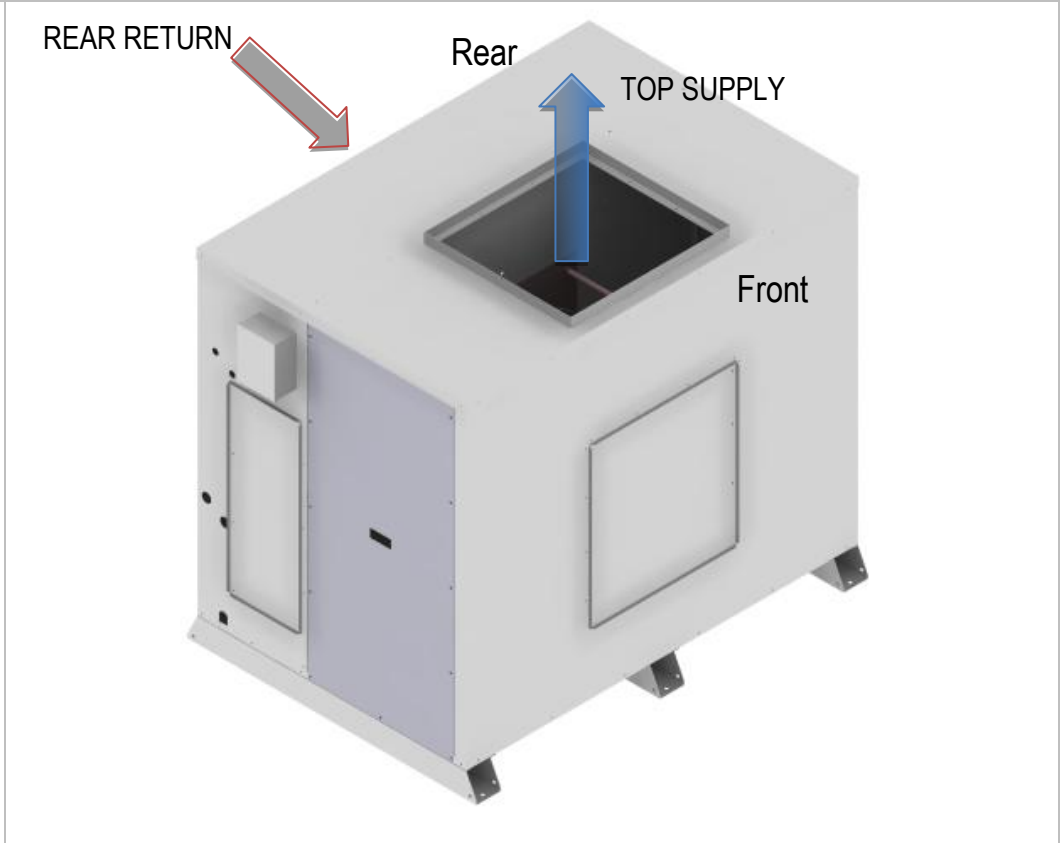
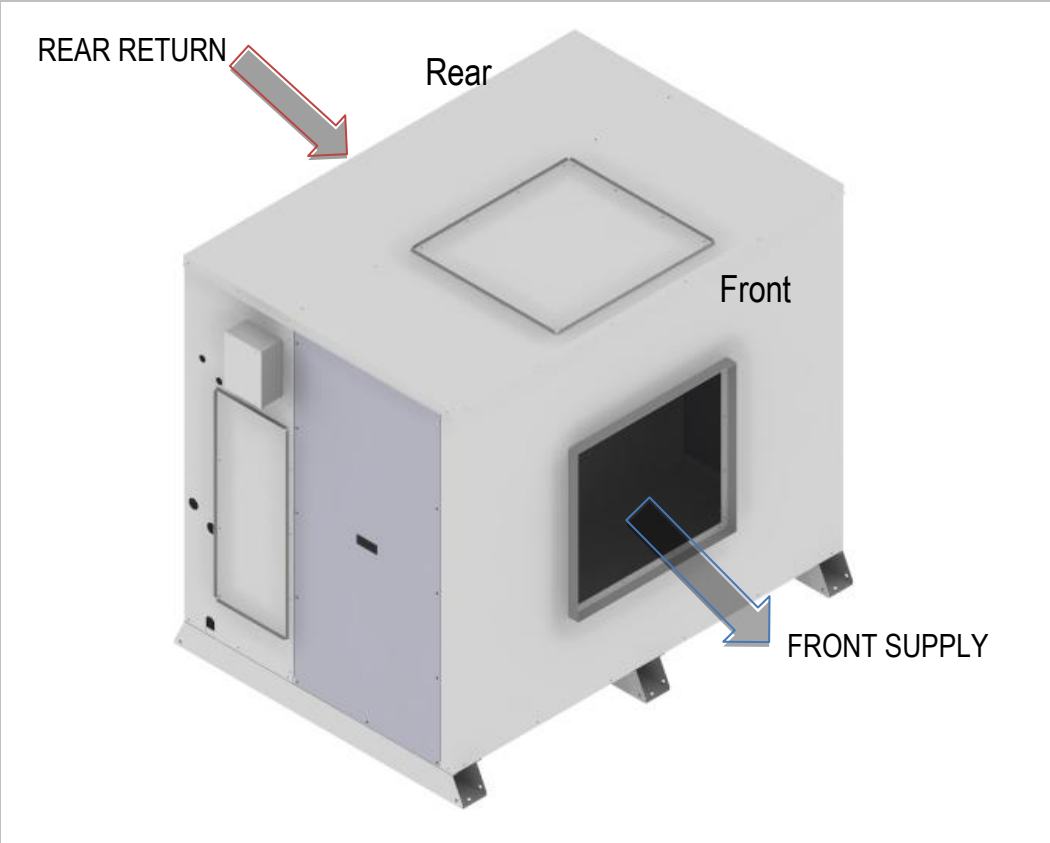

CUSTOMER TO COMPLETE AND RETURN

CUSTOMER	PROJECT	UNIT REF	NAME / SIGN	DATE

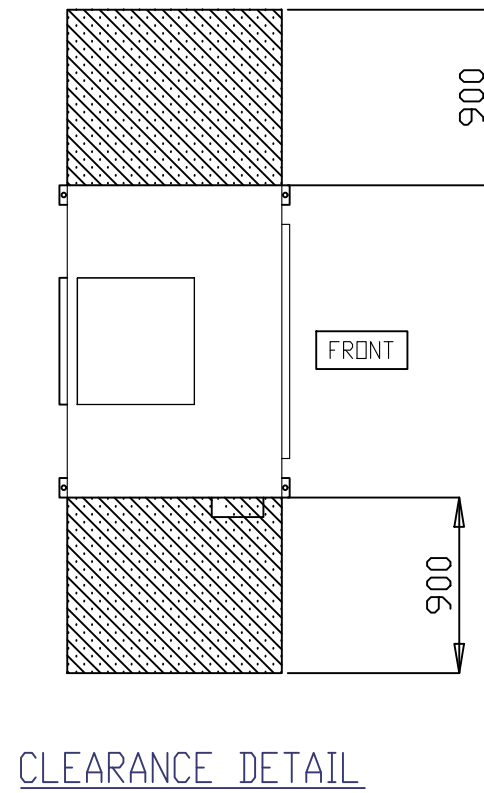
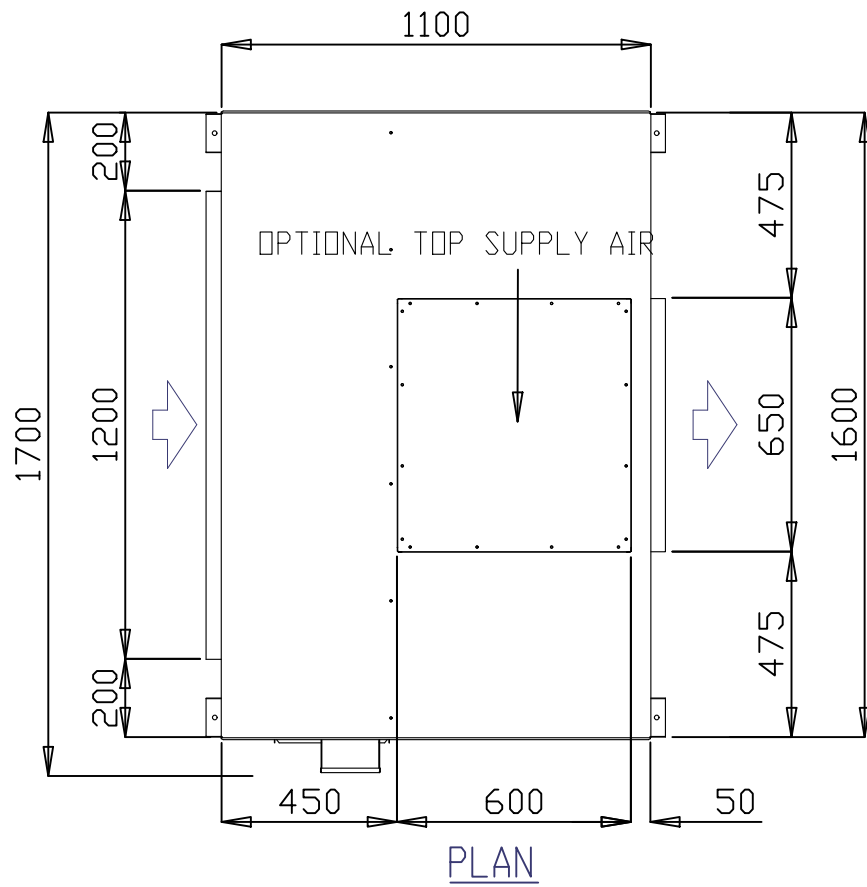

NOTES :

1. DRAWING REFLECTS A HORIZONTAL FAN COIL UNIT
2. GAS, DRAIN & ELECTRICAL CONNECTIONS ON SAME SIDE
3. ELECTRICAL CABLE ENTRY 25mm ϕ .
4. CONDENSATE DRAIN OUTLET 25.4mm ϕ
5. ACCESS DOORS ON BOTH SIDES
6. OPTIONAL TOP SUPPLY CONFIGURABLE ON SITE
7. REFER TO INSTALLATION AND OPERATIONAL MANUAL FOR PIPE SIZING

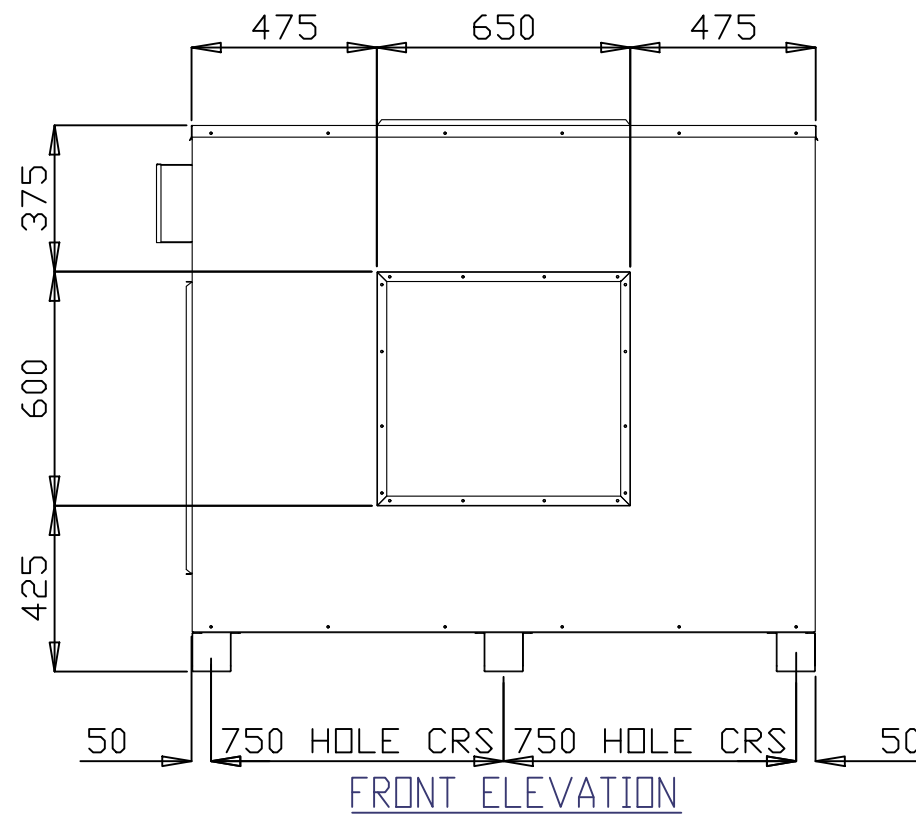
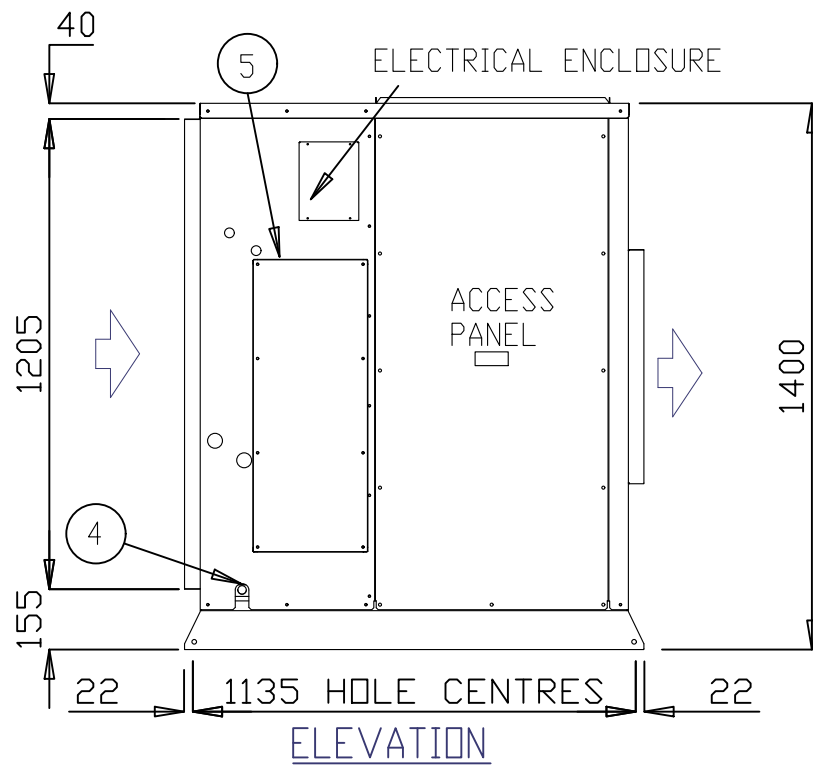

- ALL DIMENSIONS IN mm.
- GENERAL TOLERANCE ± 1 mm.
- DO NOT SCALE DRAWING.
- MASTER DRAWINGS ARE HELD ELECTRONICALLY. ANY COPY IS DEEMED UNCONTROLLED AND THEREFORE NOT NECESSARILY THE LATEST REVISION.
- ALL INFORMATION REMAINS THE PROPERTY OF THE COMPANY.

GENERAL ARRANGEMENT

S055IHR3SA-

www.apacair.com.au

ABN: 74 005 138 769

	REVISION					REVISED NAMEPLATE WITH APAC DETAILS				
		DRAWN	MT	DRAWING No.		A4				
		DATE	24.03.14	<p style="text-align: center;">GAD0016</p>						
		SCALE	N.T.S.							
	CHECKED	HA	APP'D.	CM	REV.	D				

- NOTES:
1. GENERAL ARRANGEMENT OF AN OUTDOOR SPLIT AIR COOLED VERTICAL UNIT
 2. POWER AND FIELD CABLE ENTRIES, 1 x 32 ϕ AND 2 x 25 ϕ
 3. ELECTRICAL PANEL LOCATED BEHIND SERVICE ACCESS
 4. FIELD PIPE CONNECTIONS
 5. UNIT BASE 4 x 16 ϕ FIXING POINTS
 6. UNIT HAS 4 x 20 ϕ LIFTING POINTS
 7. REFER TO INSTALLATION AND OPERATIONAL MANUAL FOR PIPE SIZING

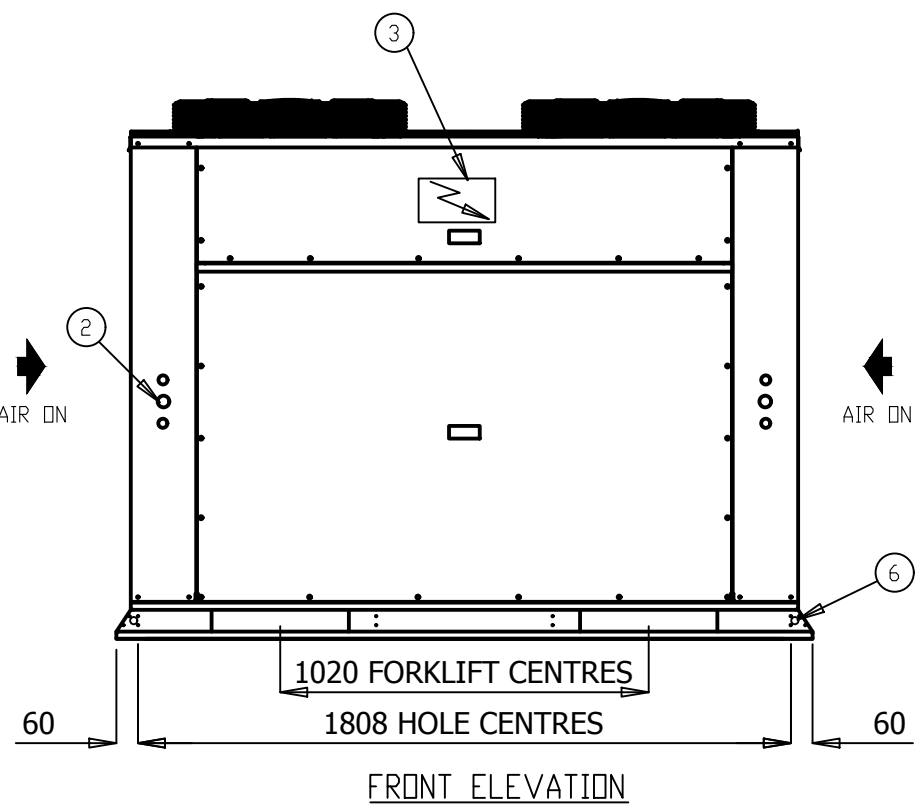
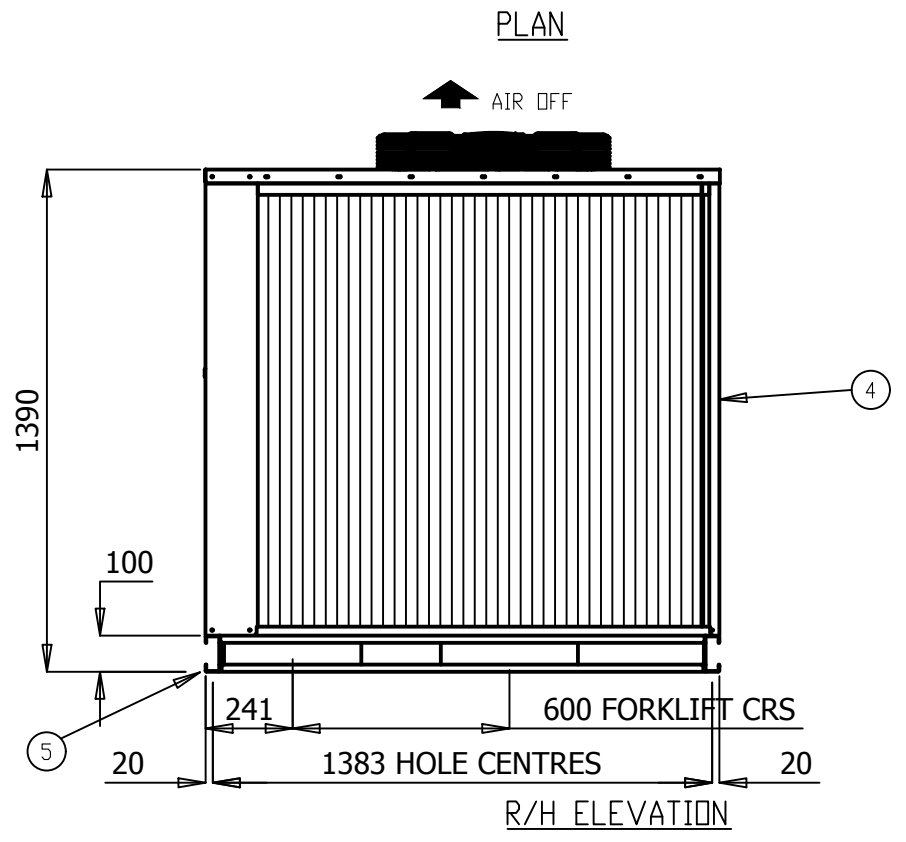
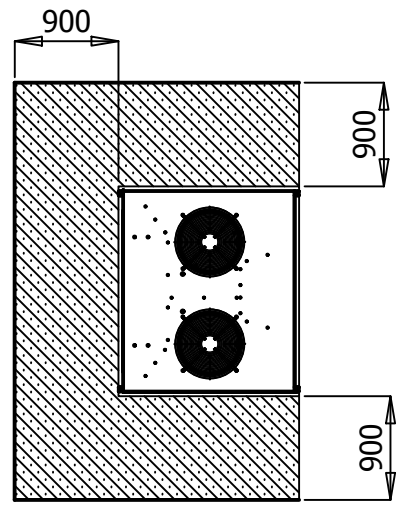
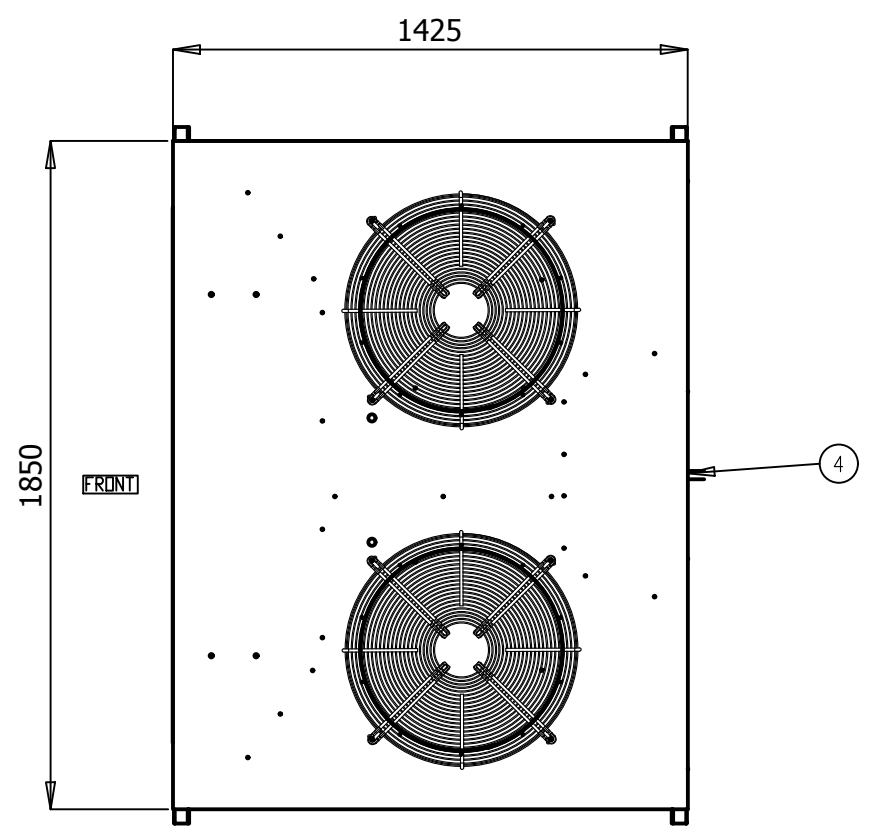

- ALL DIMENSIONS IN mm.
- GENERAL TOLERANCE ± 1 mm.
- DO NOT SCALE DRAWING.
- MASTER DRAWINGS ARE HELD ELECTRONICALLY. ANY COPY IS DEEMED UNCONTROLLED AND THEREFORE NOT NECESSARILY THE LATEST REVISION.
- ALL INFORMATION REMAINS THE PROPERTY OF THE COMPANY.

GENERAL ARRANGEMENT

S0550VR3SA-

www.apacair.com.au

ABN: 74 005 138 769

	REVISION					REVISED NAMEPLATE WITH APAC DETAILS				
	DRAWN		MT	DRAWING No.		A4				
	DATE		24.07.14	GAD0026						
	SCALE		N.T.S.							
CHECKED		HA	APP'D.	CM	REV.	C				

TECHNICAL DATA SHEET

MODEL NUMBER	Indoor	S055IHR3SA-	S065IHR3SA-	S075IHR3SA-	S085IHR3SA-	S095IHR3SA-	
	Outdoor	S055OVR3SA-	S065OVR3SA-	S075OVR3SA-	S085OVR3SA-	S095OVR3SA-	
MEPS REGISTRATION NUMBER		AAC3221	AAC3233	N/A	N/A	N/A	
OUTDOOR SECTION	CAPACITY						
	Cooling	kW TOTAL*	52.90	63.88	72.95	83.74	94.04
		kW SENSIBLE*	44.01	54.50	58.50	69.34	77.49
		EER (kW / ikW)*	3.07	3.28	3.49	3.47	3.24
	Heating	kW TOTAL	54.30	65.00	73.40	84.30	96.10
		COP	3.39	3.61	3.59	3.60	3.60
	CAPACITY STEPS (%)		50/100	50/100	50/100	50/100	50/100
	COMPRESSOR						
	TYPE		SCROLL	SCROLL	SCROLL	SCROLL	SCROLL
	STARTER TYPE		D.O.L (Opt Soft/Start)	D.O.L (Opt Soft/Start)	D.O.L (Opt Soft/Start)	D.O.L (Opt Soft/Start)	D.O.L (Opt Soft/Start)
	PHASE		3Ø	3Ø	3Ø	3Ø	3Ø
	No. OFF		2	2	2	2	2
	PROTECTION DEVICES HP SWITCH, LP SWITCH, MOTOR OVERLOAD'S						
	ALL COMPRESSORS HAVE SUMP HEATER						
	FAN						
	TYPE		EC AXIAL	EC AXIAL	EC AXIAL	EC AXIAL	EC AXIAL
	ikW (MAX INPUT)		0.97	0.93	0.93	0.93	0.93
	PHASE		3Ø	3Ø	3Ø	3Ø	3Ø
	No. OFF		2	2	2	2	2
	FAN SPEED CONTROL		VARIABLE SPEED	VARIABLE SPEED	VARIABLE SPEED	VARIABLE SPEED	VARIABLE SPEED
	HEAT EXCHANGER						
	TYPE		PLATE FIN COIL	PLATE FIN COIL	PLATE FIN COIL	PLATE FIN COIL	PLATE FIN COIL
	NOM. AIRFLOW l/s		-	-	-	-	-
	REFRIGERANT SYSTEM						
	TYPE		R410A				
FACTORY CHARGE PER CIRCUIT (KG)		5.75	6.75	9.5	11	10.8	
No. OF CIRCUITS		2	2	2	2	2	
REFRIGERANT CONTROL		TXV					
ALL SYSTEMS INCLUDE FILTER DRIERS							
DIMENSIONS							
H X W X D (mm)		1390 x 1850 x 1426	1595 x 2200 x 1425	1800 x 2200 x 1425			
WEIGHT							
OPERATING KG		510	600	610	761	783	
SHIPPING KG		515	605	615	766	788	
ELECTRICAL							
POWER SUPPLY		415v / 3Ø / 50hz					
RLA / FLA (Amps)		28.6/45.2	32.7/47	35.3/53	40.2/65	52.2/71	
INDOOR SECTION	FAN						
	TYPE		EC PLUG	EC PLUG	EC PLUG	EC PLUG	EC PLUG
	ikW (MAX INPUT)		3	2.73	2.73	2.82	2.82
	PHASE		3Ø	3Ø	3Ø	3Ø	3Ø
	No. OFF		1	2	2	2	2
	FAN SPEED CONTROL		VARIABLE SPEED	VARIABLE SPEED	VARIABLE SPEED	VARIABLE SPEED	VARIABLE SPEED
	HEAT EXCHANGER						
	TYPE		PLATE FIN COIL	PLATE FIN COIL	PLATE FIN COIL	PLATE FIN COIL	PLATE FIN COIL
	NOM. AIRFLOW l/s		2880	3550	3750	4400	4930
	EXT STATIC pa		100				
	DIMENSIONS						
	H X W X D (mm)		1400 x 1600 x 1100	1605 x 1600 x 1100	1805 x 1850 x 1100		
	WEIGHT						
	OPERATING KG		290	340	340	461	461
	SHIPPING KG		295	345	345	466	466
ELECTRICAL							
POWER SUPPLY		415v / 3Ø / 50hz					
RLA / FLA (Amps)		2.5/4.6	2.2/8.4	2.8/8.4	3.3/8.6	4.1/8.6	
COMBINED SECTIONS	ELECTRICAL						
	H.P. CUT OUT / IN kPa		4500 / 3450	4500 / 3450	4500 / 3450	4500 / 3450	4500 / 3450
	L.P. CUT OUT / IN kPa		175 / 345	175 / 345	175 / 345	175 / 345	175 / 345
	NOM. R.L.A. (TOTAL SYSTEM)		31.1	34.9	38.1	43.5	56.3
	MAX. F.L.A. (TOTAL SYSTEM)		49.8	55.4	61.4	73.6	79.6
	GENERAL						
	CABINET GALVANISED SHEET STEEL						
	INSULATION ALUMINIUM FOIL FACED POLYETHYLENE ACOUSTIC INSULATION						
	EXTERNAL FINISH POLYESTER POWDER COAT - COLOUR LIGHT GREY AS STANDARD - OPTIONS AVAILABLE						
	INDOOR AND OUTDOOR PIPE CONNECTION						
LIQUID mm (inch)		12.7 (1/2")	12.7 (1/2")	12.7 (1/2")	15.9 (5/8")	15.9 (5/8")	
GAS mm (inch)		28.6 (1-1/8")	28.6 (1-1/8")	28.6 (1-1/8")	28.6 (1-1/8")	28.6 (1-1/8")	
ADDITIONAL REFRIGERATION CHARGE AND FIELD PIPING CONNECTIONS							
REFER TO INSTALLATION AND OPERATION MANUAL							
NOISE LEVELS <small>[Based on condenser fan's sound data]</small>							
SOUND POWER db(A)		70.9	71.5	71.5	71.5	71.5	

Note:

*Performance excludes ikW of evaporator fan motor.

R.L.A - Run Load Amps are based on current drawn at nominal conditions

F.L.A - Full Load Amps are based on the overload settings [Max Current] of all Compressor and Fan Motor(s).

This TDS is also applicable to models: ASCE055HA3A-ASCC055VA3A; ASCE065HA3A-ASCC065VA3A; ASCE075HA3A-ASCC075HA3A; ASCE085HA3A-ASCC085VA3A; ASCE095HA3A-ASCC095VA3A.

Date	Document #	Approved By	Revision
1/6/18	TDS0023	CM	D

NOTE: Due to continuous improvement Rinnai Australia Pty Ltd reserve the right to change details without notice.

FAN PERFORMANCE CURVE

S055IHR3SA-

FAN PERFORMANCE CURVE S055IHR3SA-

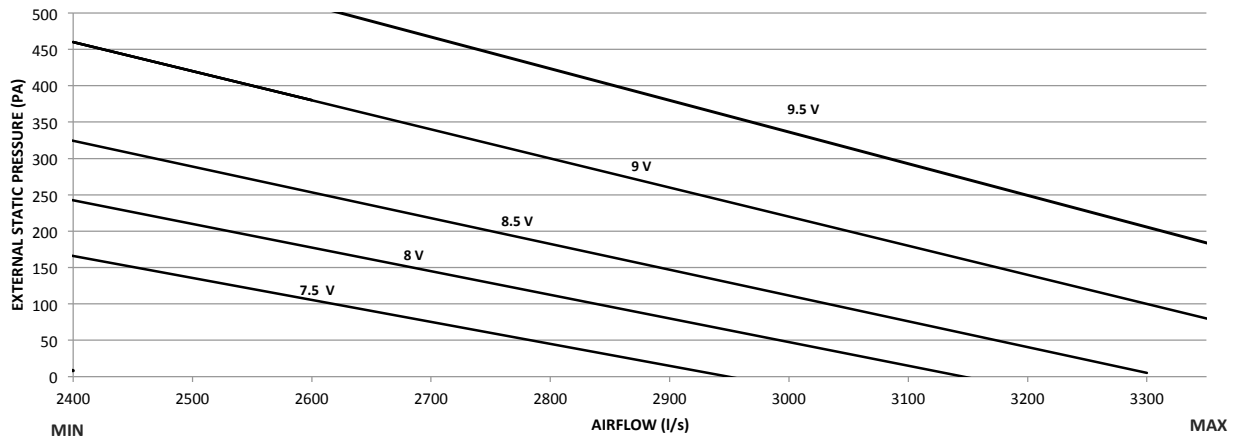

Note:

1. 7.5V, 8V, 8.5V, 9V and 9.5V represents potentiometer voltage. Potentiometer can be adjusted to achieve desired flowrates.
2. Potentiometer voltage can be varied infinitely between 0 to 10V.

Date	Document #	Approved By	Revision
29.05.18	FPC0038	CM	B

NOTE: Due to continuous improvement Rinnai Australia Pty Ltd reserve the right to change details without notice.



SOUND DATA

MODEL NUMBER

S055IHR3SA- / S055OVR3SA-

Outdoor Fan

Sound Power Level dB(A)	Octave band Centre Frequency (Hz), dB						
	125	250	500	1k	2k	4k	8k
70.9	74.1	66.2	67.9	65	63.1	61.4	58.2

Indoor Fan

Sound Power Level dB(A)	Air Flow (l/s)	Octave band Centre Frequency (Hz), dB						
		125	250	500	1k	2k	4k	8k
85.1	2880	73.8	78.4	81.1	79.2	79.7	73.4	72.8

Date	Document #	Approved By	Revision
01.06.18	SD0024	CM	B

NOTE: Due to continuous improvement Rinnai Australia Pty Ltd reserve the right to change details

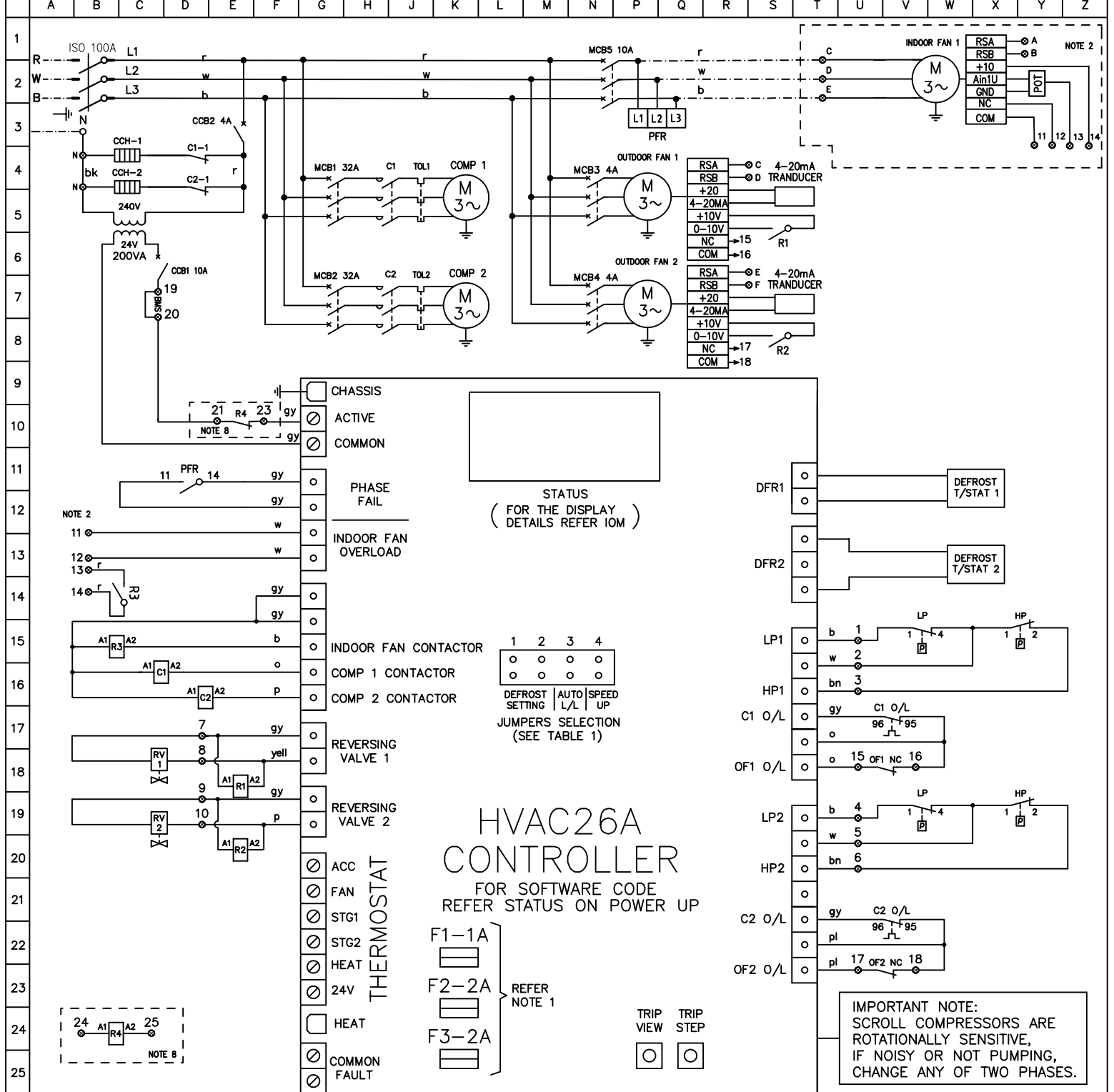

WARNING! THE SOFTWARE OF THE HVAC26A CONTROLLER IS NOT DESIGNED TO FUNCTION AS A PRIMARY PERSONAL SAFETY DEVICE AS CONNECTED EQUIPMENT CAN START AUTOMATICALLY WITHOUT WARNING. ALSO OPENING THE THERMOSTAT CONTACTS MAY NOT CAUSE THE EQUIPMENT TO STOP. OUTDOOR FAN MOTORS HAVE INTERNAL OVERLOADS AND MAY RESTART AUTOMATICALLY.

- NOTES:
- TIME DELAY GLASS FUSES ON THE PCB CONTROLLER ARE THE FOLLOWING:
 - F1 PROTECTS THE THERMOSTAT CIRCUIT.
 - F2 PROTECTS THE REVERSING VALVE CIRCUITS AND THE "HEAT" OUTPUT. THIS FUSE F2 ALSO SUPPLIES FUSE F1.
 - F3 PROTECTS BOTH COMPRESSOR CONTACTOR CIRCUITS.
 - FOR SPLIT SYSTEMS, OTHERS TO INSTALL ISOLATOR AND FIELD WIRING
 - HP CUT OUT , LP CUT OUT - AUTO RESET.
 - THERMAL OVERLOAD RELAYS - MANUAL RESET, UNLESS OTHERWISE STATED.
 - DO NOT CONNECT ANY ADDITIONAL EQUIPMENT TO THE CONTROL TRANSFORMER OTHER THAN THE EQUIPMENT SHOWN ON THE ELECTRICAL DRAWING.
 - ALL FIELD WIRING IS THE RESPONSIBILITY OF THE INSTALLING CONTRACTOR AND MUST COMPLY WITH AS/NZS 3000 AND LOCAL RULES.
 - SOFTWARE CODE MUST BE CHECKED AFTER REPLACEMENT OF THE HVAC26A CONTROLLER BY CHECKING THE DISPLAY CODE ON THE LCD DISPLAY AFTER THE CONTROLLER IS ACTIVATED.
 - OPTIONAL FIRE ALARM RELAY

TABLE 1

JUMPERS SELECTION	DEFROST INTERVAL TIME SETTING	JUMPERS SELECTION	AUTO LEAD/LAG	JUMPERS SELECTION	SPEED UP
1 2 ○ ○	15 min	3 ○ ○	OFF	4 ○ ○	OFF
1 2 ■ ○	FACTORY SETTING 30 min	3 ■ ○	ON	4 ■ ○	ON
1 2 ■ ■	45 min	3 ■ ■		4 ■ ■	

UNIT MUST BE SWITCHED OFF BEFORE CHANGING THE JUMPER SELECTION

LEGEND		LEGEND		COLOUR CODE		COMPRESSOR (EACH)		MODEL: S0550VR3SA-H		 DATE 08/11/2018 DWN N.J APPD C.M REV B GRID B172 DWG No. EWS02153
○	TERMINAL SWITCHBOARD	TOL	THERMAL OVERLOAD RELAY	r	RED	KW 6.74		OPTIONS		
⊙	TERMINAL	R	RELAY	w	WHITE	RATED CURRENT 21.00		DESCRIPTION		
---	FIELD WIRING	C	CONTACTOR	b	BLUE	O/L SETTING 23.10		STANDARD		
---	CONTROL PARAMETER	COMP	COMPRESSOR	bk	BLACK	FANS (EACH) KW FLA				
---	MAINS/CONTROL	ISO	ISOLATOR SWITCH	bn	BROWN	OUTDOOR 0.97 1.60				
---	WIRING	MCB	MINIATURE CIRCUIT BREAKER	o	ORANGE	INDOOR 2.86 4.30				
CCH	CRANK CASE HEATER	CCB	CONTROL CIRCUIT BREAKER	p	PINK					
PFR	PHASE FAILURE RELAY	O/L	OVERLOAD	pl	PURPLE					
RV	REVERSING VALVE	POT	POTENTIOMETER	gy	GREY					
HP	HIGH PRESSURE SWITCH			yell	YELLOW					
LP	LOW PRESSURE SWITCH									