

DIMENSION	S024-035	S040-045
A	1145	1600
B	700	245

NOTES:

1. GENERAL ARRANGEMENT OF A VERTICAL AIR COOLED PACKED UNIT
2. POWER AND FIELD CABLE ENTRIES, 1 x 32 ϕ AND 2 x 25 ϕ (BOTH SIDES)
3. ELECTRICAL PANEL LOCATED BEHIND SERVICE ACCESS
4. CONDENSATE OUTLET 25 ϕ
5. UNIT BASE 4 x 16 ϕ FIXING POINTS
6. UNIT CONFIGURATION IS TOP SUPPLY, REAR RETURN
7. REFRIGERANT PIPE CONNECTIONS

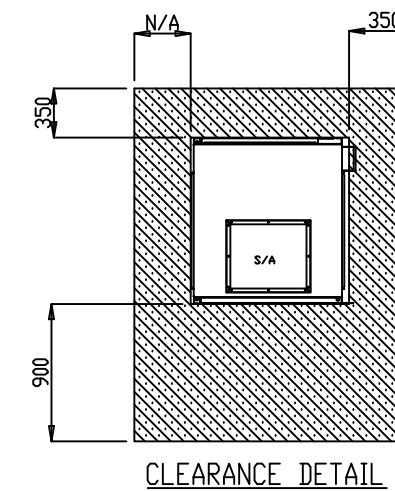
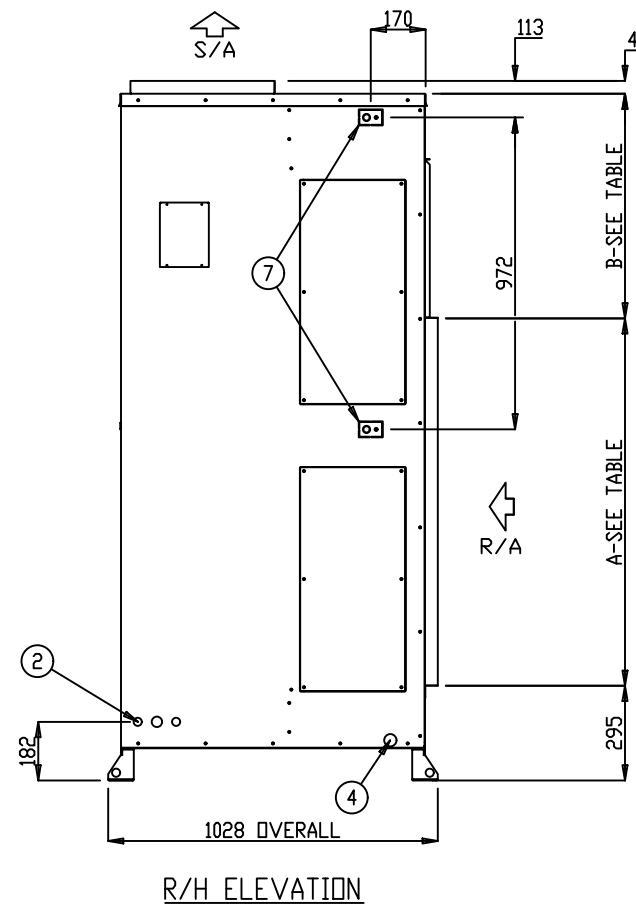
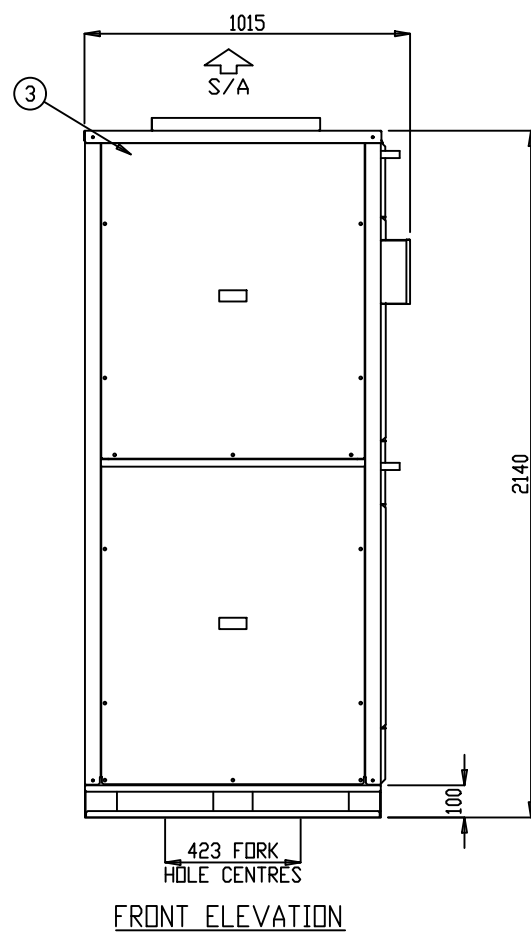

- ALL DIMENSIONS IN mm.
- GENERAL TOLERANCE ± 1 mm.
- DO NOT SCALE DRAWING.
- MASTER DRAWINGS ARE HELD ELECTRONICALLY. ANY COPY IS DEEMED UNCONTROLLED AND THEREFORE NOT NECESSARILY THE LATEST REVISION.
- ALL INFORMATION REMAINS THE PROPERTY OF THE COMPANY.

GENERAL ARRANGEMENT

S024IVR3SA- S030IVR3SA- S035IVR3SA- S040IVR3SA- S045IVR3SA-

www.apacair.com.au

ABN: 74 005 138 769

REVISION

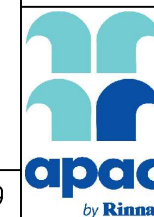

PIPE CONNECTIONS DIMENSIONED, QTY DOOR FASTENERS CORRECTED

DRAWN	HA	DRAWING No.	A4
DATE	08.07.19	GAD0024	
SCALE	N.T.S.		
CHECKED	HA	APP'D.	NJ
		REV.	E

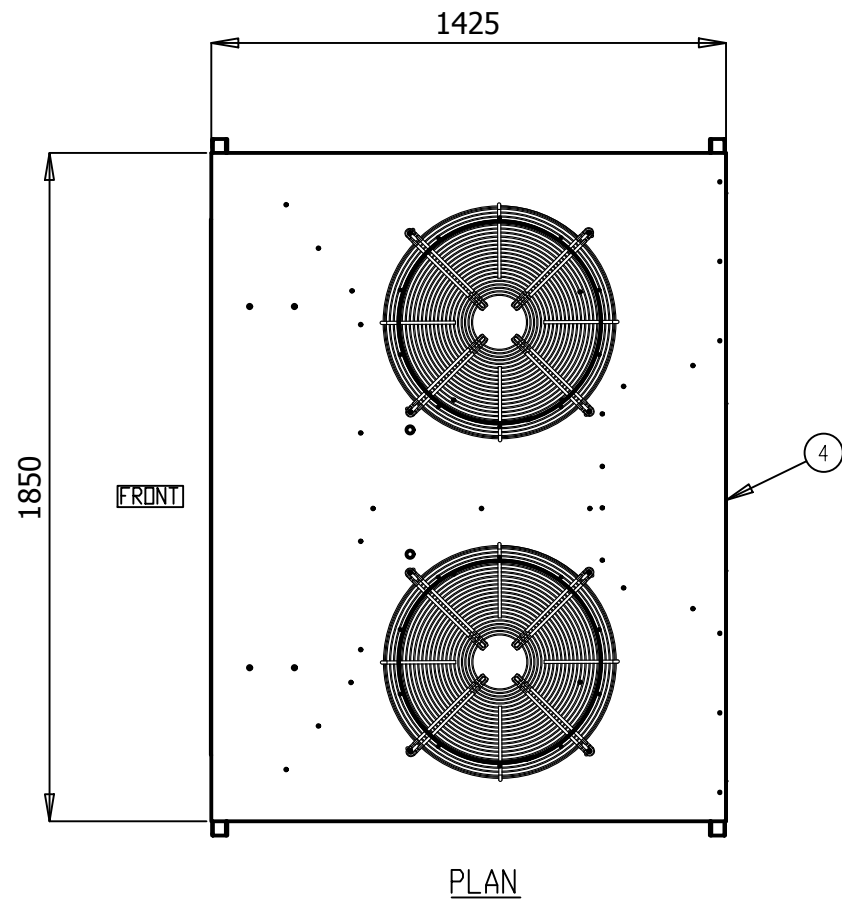

- NOTES:
1. GENERAL ARRANGEMENT OF A OUTDOOR SPLIT AIR COOLED VERTICAL UNIT
 2. POWER AND FIELD CABLE ENTRIES, 1 x 32 ϕ AND 2 x 25 ϕ
 3. ELECTRICAL PANEL LOCATED BEHIND SERVICE ACCESS
 4. FIELD PIPE CONNECTIONS
 5. UNIT BASE 4 x 16 ϕ FIXING POINTS
 6. UNIT HAS 4 x 20 ϕ LIFTING POINTS
 7. REFER TO INSTALLATION AND OPERATIONAL MANUAL FOR PIPE SIZING

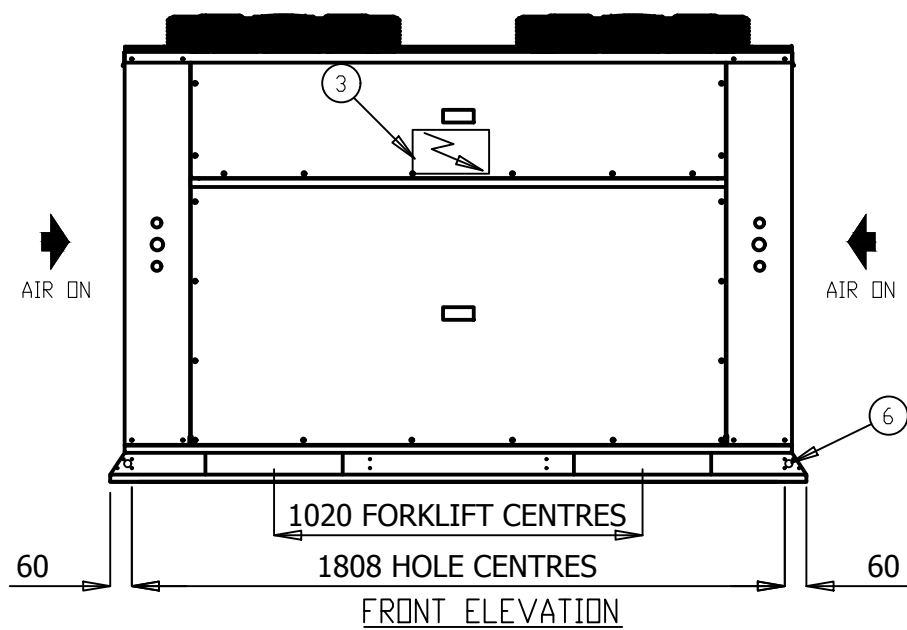
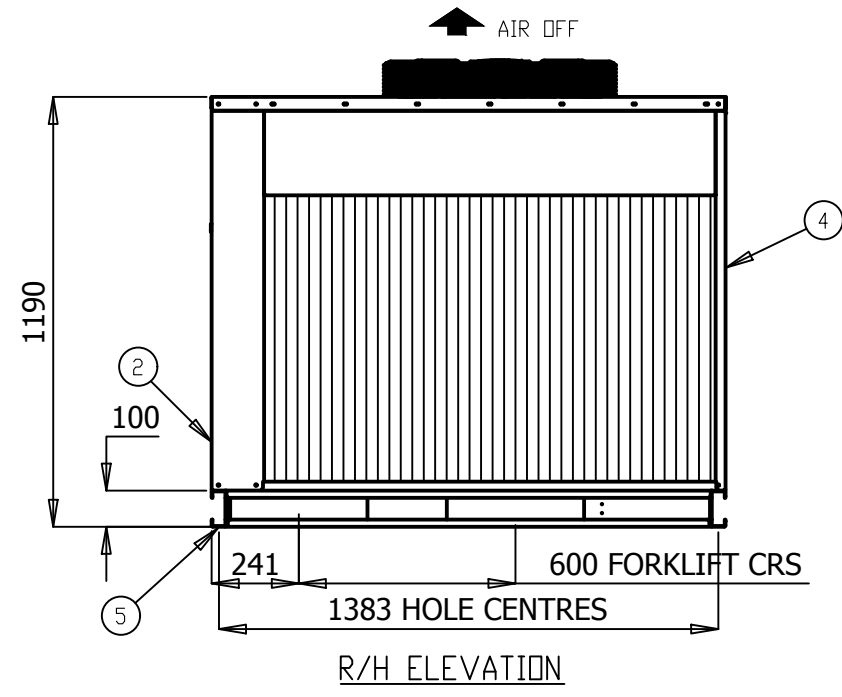
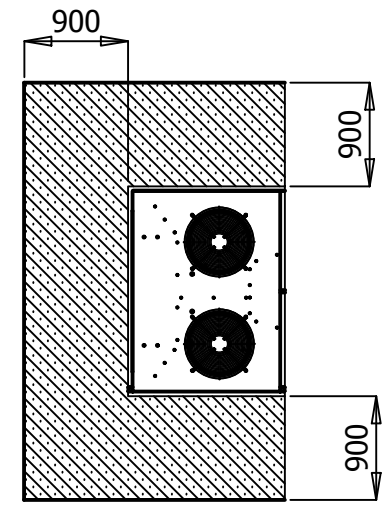

- ALL DIMENSIONS IN mm.
- GENERAL TOLERANCE ± 1 mm.
- DO NOT SCALE DRAWING.
- MASTER DRAWINGS ARE HELD ELECTRONICALLY. ANY COPY IS DEEMED UNCONTROLLED AND THEREFORE NOT NECESSARILY THE LATEST REVISION.
- ALL INFORMATION REMAINS THE PROPERTY OF THE COMPANY.

GENERAL ARRANGEMENT

S0240VR3SA- S0300VR3SA- S0350VR3SA- S0400VR3SA- S0450VR3SA-

www.apacair.com.au

ABN: 74 005 138 769

	REVISION					REVISED NAMEPLATE WITH APAC DETAILS				
	DRAWN		MT	DRAWING No.		A4				
	DATE		24.08.14	<h2>GAD0028</h2>						
	SCALE		N.T.S.							
CHECKED		HA	APP'D.	CM	REV.	D				

TECHNICAL DATA SHEET

MODEL NUMBER	Indoor	S024IVR3SA-	S030IVR3SA-	S035IVR3SA-	S040IVR3SA-	S045IVR3SA-	
	Outdoor	S024OVR3SA-	S030OVR3SA-	S035OVR3SA-	S040OVR3SA-	S045OVR3SA-	
MEPS REGISTRATION NUMBER		AAC3261	AAC3275	AAC3260	AAC3251	AAC3259	
OUTDOOR SECTION	CAPACITY						
	Cooling	kW TOTAL*	25.15	31.02	34.13	39.78	45.27
		kW SENSIBLE*	19.39	25.97	28.12	32.42	36.62
		EER (kW / ikW)*	3.59	3.60	3.44	3.40	3.27
	Heating	kW TOTAL	23.80	30.20	33.60	40.10	43.50
		COP	3.66	3.60	3.78	3.61	3.71
		CAPACITY STEPS (%)	50/100	50/100	50/100	50/100	50/100
	COMPRESSOR						
	TYPE	SCROLL					
	STARTER TYPE	D.O.L (Opt Soft/Start)					
	PHASE	3Ø					
	No. OFF	2					
	PROTECTION DEVICES	HP SWITCH, LP SWITCH, MOTOR OVERLOAD'S					
	ALL COMPRESSORS HAVE	CRANKCASE HEATER					
	FAN						
	TYPE	AXIAL					
	ikW (MAX INPUT)	0.39					
	PHASE	1Ø					
	No. OFF	2					
	FAN SPEED CONTROL	VARIABLE SPEED					
	HEAT EXCHANGER						
	TYPE	PLATE FIN COIL					
	NOM. AIRFLOW l/s	-					
	REFRIGERANT SYSTEM						
	TYPE	R410A					
FACTORY CHARGE PER CIRCUIT (KG)	3.95						
No. OF CIRCUITS	2						
REFRIGERANT CONTROL	TXV						
ALL SYSTEMS INCLUDE	DRIERS & SIGHT GLASSES						
DIMENSIONS							
H X W X D (mm)	1190 x 1850 x 1425						
WEIGHT							
OPERATING KG	362						
SHIPPING KG	366						
ELECTRICAL							
POWER SUPPLY	415v / 3Ø / 50hz						
FLA / RLA (Amps)	19.6 / 12.8						
INDOOR SECTION							
FAN							
TYPE	CENTRIFUGAL						
ikW (MAX INPUT)	2.73						
PHASE	3Ø						
No. OFF	1						
FAN SPEED CONTROL	VARIABLE SPEED						
HEAT EXCHANGER							
TYPE	PLATE FIN COIL						
NOM. AIRFLOW l/s	1250						
EXT STATIC pa	100						
DIMENSIONS							
H X W X D (mm)	2140 x 925 x 950						
WEIGHT							
OPERATING KG	192						
SHIPPING KG	195						
ELECTRICAL							
POWER SUPPLY	415v / 3Ø / 50hz						
FLA / RLA (Amps)	4.2 / 1.1						
COMBINED SECTIONS							
ELECTRICAL							
H.P. CUT OUT / IN kPa	4500 / 3450						
L.P. CUT OUT / IN kPa	175 / 345						
NOM. R.L.A. (TOTAL SYSTEM)	13.6						
MAX. F.L.A. (TOTAL SYSTEM)	23.8						
GENERAL							
CABINET	GALVANISED SHEET STEEL						
INSULATION	ALUMINIUM FOIL FACED POLYETHYLENE ACOUSTIC INSULATION						
EXTERNAL FINISH	POLYESTER POWDER COAT - COLOUR LIGHT GREY AS STANDARD - OPTIONS AVAILABLE						
INDOOR AND OUTDOOR PIPE CONNECTION							
LIQUID mm (inch)	9.5 (3/8")						
GAS mm (inch)	15.9 (5/8")						
ADDITIONAL REFRIGERATION CHARGE AND FIELD PIPING CONNECTIONS							
REFER TO INSTALLATION AND OPERATION MANUAL							
NOISE LEVELS [Based on condenser fan's sound data]							
SOUND POWER db(A)	66.5						

Note:

*Performance excludes ikW of evaporator fan motor.

R.L.A - Run Load Amps are based on current drawn at nominal conditions

F.L.A - Full Load Amps are based on the overload settings [Max Current] of all Compressor and Fan Motor(s).

Date	Document #	Approved By	Revision
1/6/18	TDS0044	CM	B

NOTE: Due to continuous improvement Rinnai Australia Pty Ltd reserve the right to change details without notice.

FAN PERFORMANCE CURVE

S040IVR3SA-

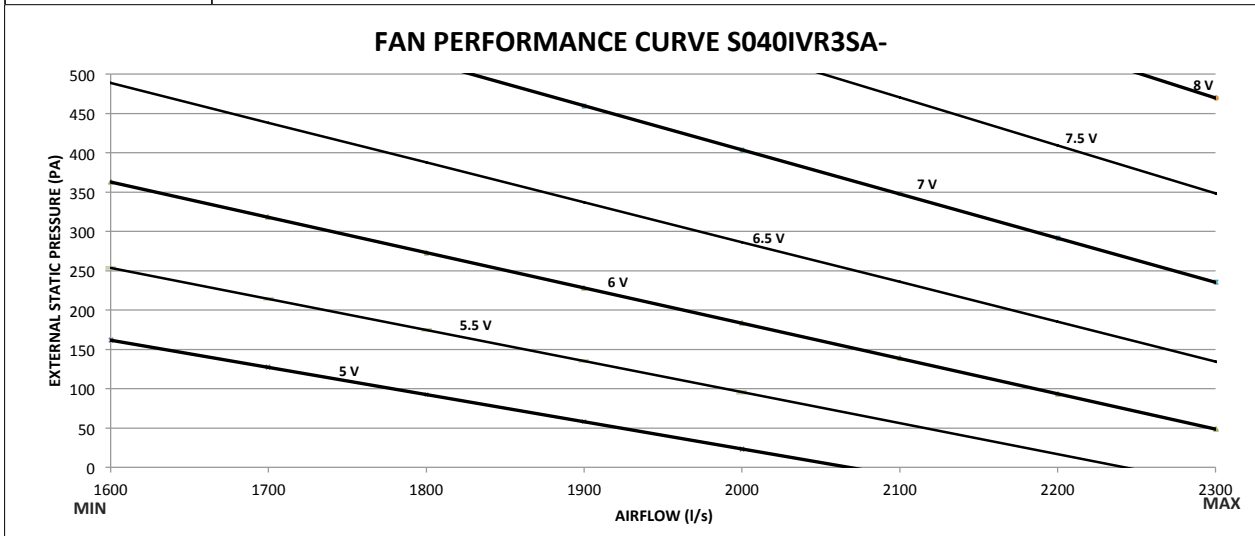

Note:

1. 5V, 5.5V, 6V, 6.5V, 7V, 7.5V and 8V represents potentiometer voltage. Potentiometer can be adjusted to achieve desired flowrates.
2. Potentiometer voltage can be varied infinitely between 0 to 10V.

Date	Document #	Approved By	Revision
29.05.18	FPC0045	CM	B

NOTE: Due to continuous improvement Rinnai Australia Pty Ltd reserve the right to change details without notice.



SOUND DATA

MODEL NUMBER

S040IVR3SA- / S040OVR3SA-

Outdoor Fan

Sound Power Level dB(A)	Octave band Centre Frequency (Hz), dB						
	125	250	500	1k	2k	4k	8k
68.7	75.6	63.7	64.1	63.2	61.4	58.2	52.3

Indoor Fan

Sound Power Level dB(A)	Air Flow (l/s)	Octave band Centre Frequency (Hz), dB						
		125	250	500	1k	2k	4k	8k
82.8	1984	64.9	71.9	75	78.5	75.7	74.5	73.4

Date	Document #	Approved By	Revision
07.06.18	SD0060	CM	B

NOTE: Due to continuous improvement Rinnai Australia Pty Ltd reserve the right to change details

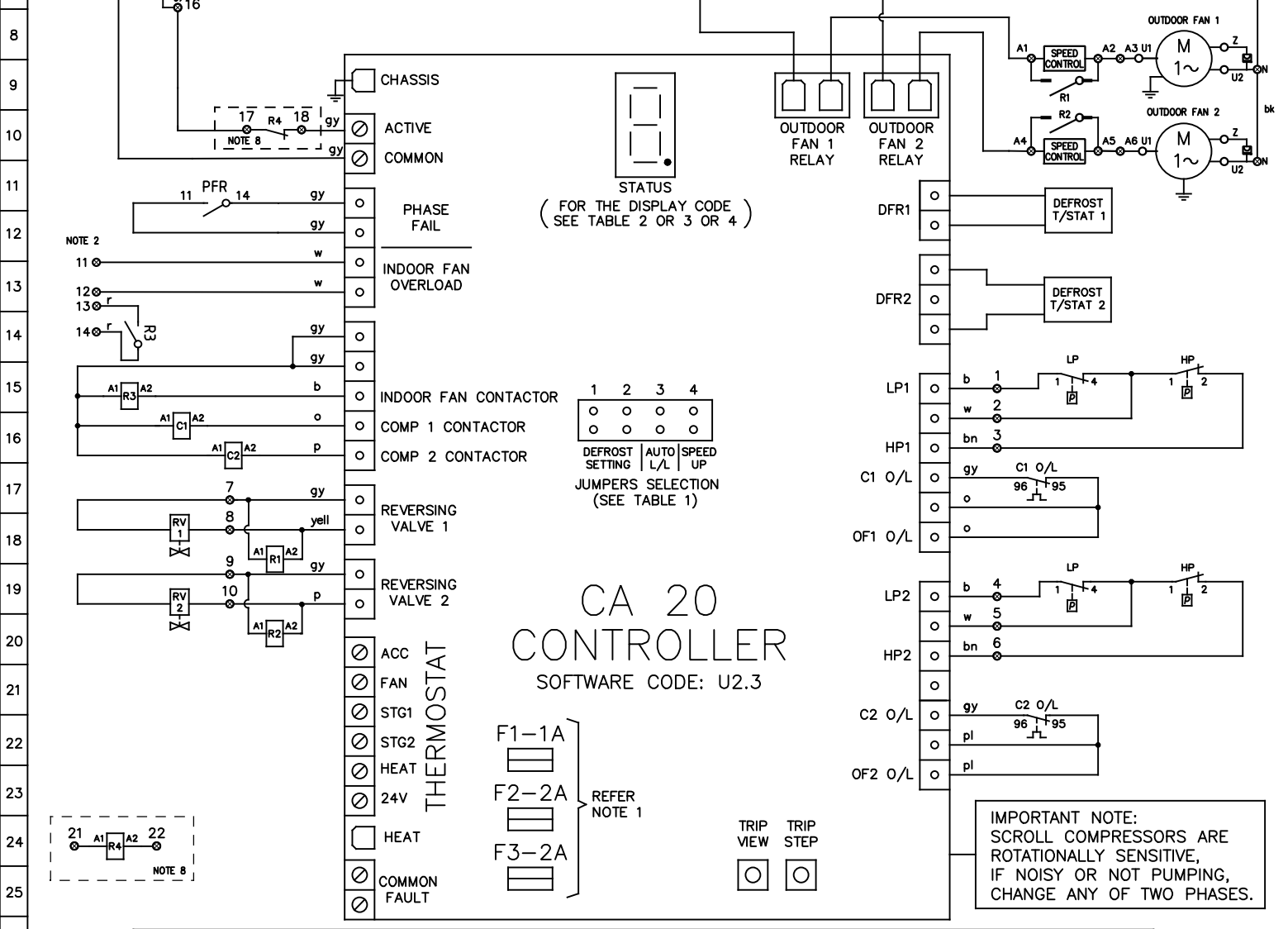
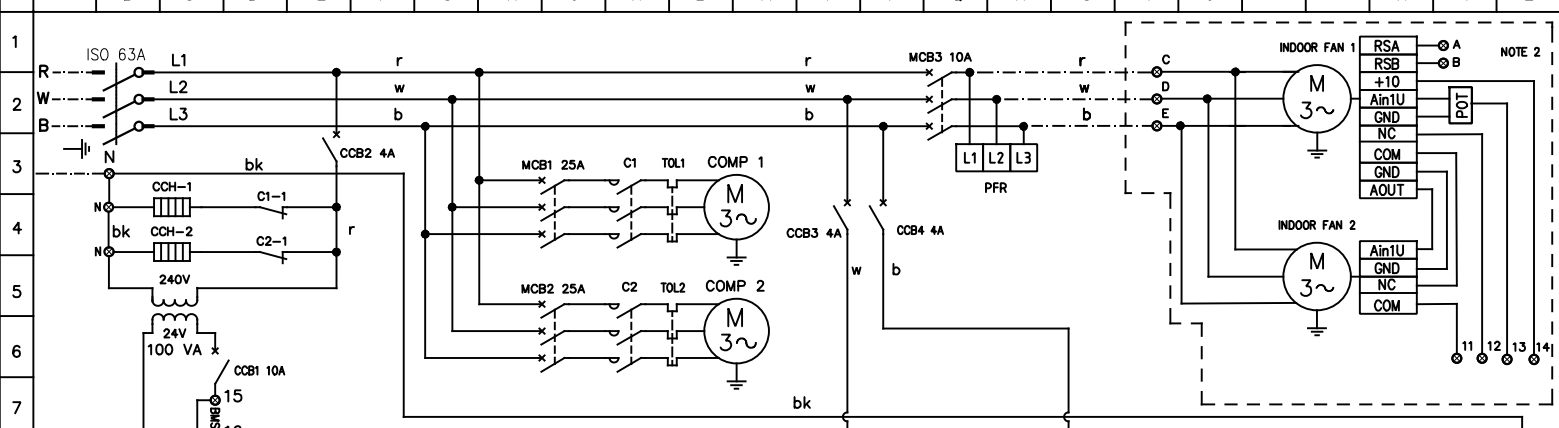

CA 20 CONTROLLER

SOFTWARE CODE: U2.3

IMPORTANT NOTE:
SCROLL COMPRESSORS ARE ROTATIONALLY SENSITIVE, IF NOISY OR NOT PUMPING, CHANGE ANY OF TWO PHASES.

WARNING! THE SOFTWARE OF THE CA20 CONTROLLER IS NOT DESIGNED TO FUNCTION AS A PRIMARY PERSONAL SAFETY DEVICE, AS CONNECTED EQUIPMENT CAN START AUTOMATICALLY WITHOUT WARNING. ALSO, OPENING THERMOSTAT CONTACTS MAY NOT CAUSE THE EQUIPMENT TO STOP. OUTDOOR FAN MOTORS HAVE INTERNAL OVERLOADS AND MAY RESTART AUTOMATICALLY.

- NOTES:
- TIME DELAY GLASS FUSES ON THE PCB CONTROLLER ARE THE FOLLOWING:
 - F1 PROTECTS THE THERMOSTAT CIRCUIT.
 - F2 PROTECTS THE REVERSING VALVE CIRCUITS AND THE "HEAT" OUTPUT. THIS FUSE F2 ALSO SUPPLIES FUSE F1.
 - F3 PROTECTS BOTH COMPRESSOR CONTACTOR CIRCUITS AND THE INDOOR FAN CONTACTOR CIRCUIT.
 - FOR SPLIT SYSTEMS. OTHERS TO INSTALL ISOLATOR AND FIELD WIRING
 - HP CUT OUT & LP CUT OUT - AUTO RESET.
 - THERMAL OVERLOAD RELAYS - AUTO RESET, UNLESS OTHERWISE STATED.
 - DO NOT CONNECT ANY ADDITIONAL EQUIPMENT TO THE CONTROL TRANSFORMER OTHER THAN THE EQUIPMENT SHOWN ON THE ELECTRICAL DRAWING.
 - ALL FIELD WIRING IS THE RESPONSIBILITY OF THE INSTALLING CONTRACTOR AND MUST COMPLY WITH AS/NZS 3000 AND LOCAL RULES.
 - SOFTWARE CODE MUST BE CHECKED AFTER REPLACEMENT OF THE CA-20 CONTROLLER BY CHECKING THE DISPLAY CODE ON THE 7 SEGMENT DISPLAY AFTER THE CONTROLLER IS ACTIVATED.
 - OPTIONAL FIRE ALARM RELAY

JUMPERS SELECTION	DEFROST INTERVAL TIME SETTING	JUMPERS SELECTION	AUTO LEAD/LAG	JUMPERS SELECTION	SPEED UP										
<table border="1"> <tr><td>1</td><td>2</td></tr> <tr><td>○</td><td>○</td></tr> <tr><td>○</td><td>○</td></tr> </table>	1	2	○	○	○	○	15 min	<table border="1"> <tr><td>3</td></tr> <tr><td>○</td></tr> </table>	3	○	OFF	<table border="1"> <tr><td>4</td></tr> <tr><td>○</td></tr> </table>	4	○	OFF
1	2														
○	○														
○	○														
3															
○															
4															
○															
<table border="1"> <tr><td>1</td><td>2</td></tr> <tr><td>○</td><td>○</td></tr> <tr><td>○</td><td>○</td></tr> </table>	1	2	○	○	○	○	FACTORY SETTING 30 min	<table border="1"> <tr><td>3</td></tr> <tr><td>○</td></tr> </table>	3	○	ON	<table border="1"> <tr><td>4</td></tr> <tr><td>○</td></tr> </table>	4	○	ON
1	2														
○	○														
○	○														
3															
○															
4															
○															
<table border="1"> <tr><td>1</td><td>2</td></tr> <tr><td>○</td><td>○</td></tr> <tr><td>○</td><td>○</td></tr> </table>	1	2	○	○	○	○	45 min	<table border="1"> <tr><td>3</td></tr> <tr><td>○</td></tr> </table>	3	○	ON	<table border="1"> <tr><td>4</td></tr> <tr><td>○</td></tr> </table>	4	○	ON
1	2														
○	○														
○	○														
3															
○															
4															
○															

UNIT MUST BE SWITCHED OFF BEFORE CHANGING THE JUMPER SELECTION

LEGEND		LEGEND		COLOUR CODE		COMPRESSOR (EACH)		MODEL: S0400VR3SA-V					
○	TERMINAL SWITCHBOARD	TOL	THERMAL OVERLOAD RELAY	r	RED	KW	4.86	OPTIONS DESCRIPTION					
⊗	TERMINAL	R	RELAY	w	WHITE	RATED CURRENT	15.00						
- - -	FIELD WIRING	C	CONTACTOR	b	BLUE	O/L SETTING	16.50	STANDARD					
- - -	CONTROL PARAMETER	COMP	COMPRESSOR	bk	BLACK	FANS (EACH) KW	FLA						
- - -	ISO	MCB	MINIATURE CIRCUIT BREAKER	bn	BROWN	OUTDOOR	0.60	2.62					
- - -	MAINS/CONTROL WIRING	CCB	CONTROL CIRCUIT BREAKER	o	ORANGE	INDOOR	1.70	2.60					
CCH	CRANK CASE HEATER	O/L	OVERLOAD	p	PINK	DATE 17/06/2018							
PFR	PHASE FAILURE RELAY	POT	POTENTIOMETER	pl	PURPLE					DWN S.P APPD ENG			
RV	REVERSING VALVE			gy	GREY								
HP	HIGH PRESSURE SWITCH			ye	YELLOW	DWG No. EWS02205							
LP	LOW PRESSURE SWITCH												



apac
by Rianni

DATE 17/06/2018

DWN S.P APPD ENG

REV A GRID B227

DWG No. EWS02205