

PLAN

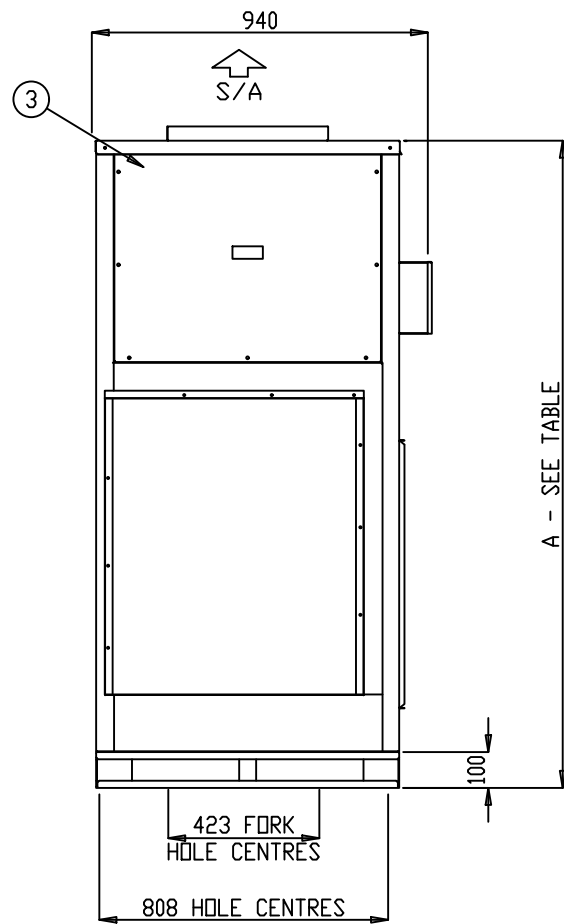

FRONT ELEVATION

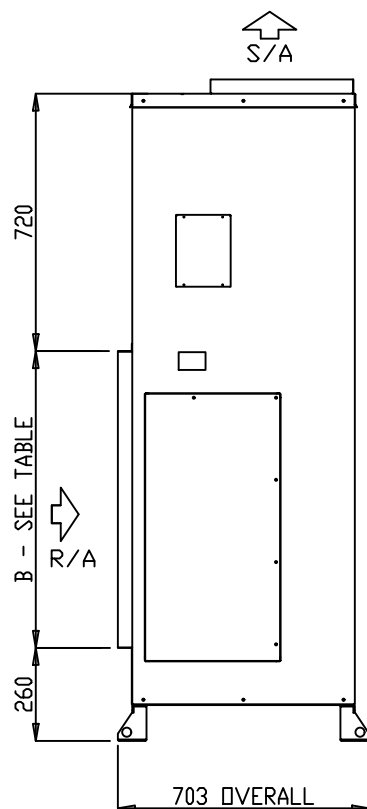

R/H ELEVATION

NOTES:

1. GENERAL ARRANGEMENT OF A SPLIT DUCTED INDOOR VERTICAL UNIT
2. POWER AND FIELD CABLE ENTRIES, 1 x 32Ø AND 2 x 25Ø (RIGHT HAND SIDE)
3. FIELD PIPE CONNECTIONS (RIGHT HAND SIDE)
4. CONDENSATE OUTLET 25Ø
5. UNIT BASE 4 x 16Ø FIXING POINTS
6. UNIT CONFIGURATION IS TOP SUPPLY, FRONT RETURN

DIMENSION	S012-018	S020-023
A	1580	1810
B	600	830

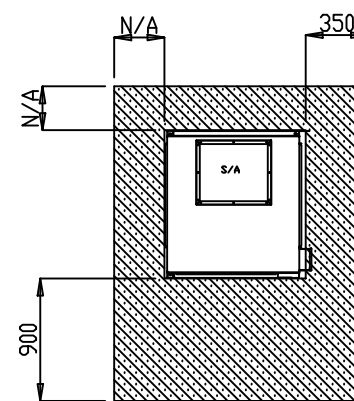

CLEARANCE DETAIL

- ALL DIMENSIONS IN mm.
- GENERAL TOLERANCE ±1mm.
- DO NOT SCALE DRAWING.
- MASTER DRAWINGS ARE HELD ELECTRONICALLY. ANY COPY IS DEEMED UNCONTROLLED AND THEREFORE NOT NECESSARILY THE LATEST REVISION.
- ALL INFORMATION REMAINS THE PROPERTY OF THE COMPANY.

GENERAL ARRANGEMENT

S012IVR3SA- S015IVR3SA- S018IVR3SA- S020IVR3SA- S023IVR3SA-

www.apacair.com.au

ABN: 74 005 138 769

REVISION

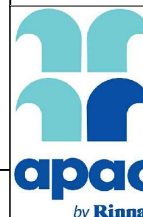

REVISED NAMEPLATE WITH APAC DETAILS

DRAWN	MT	DRAWING No.	A4
DATE	30.09.16	GAD0068	
SCALE	N.T.S.	APP'D.	CM
CHECKED	HA	REV.	B

ATLANTIC DR.
KEYSBOROUGH
VIC 3173
1300 555 545

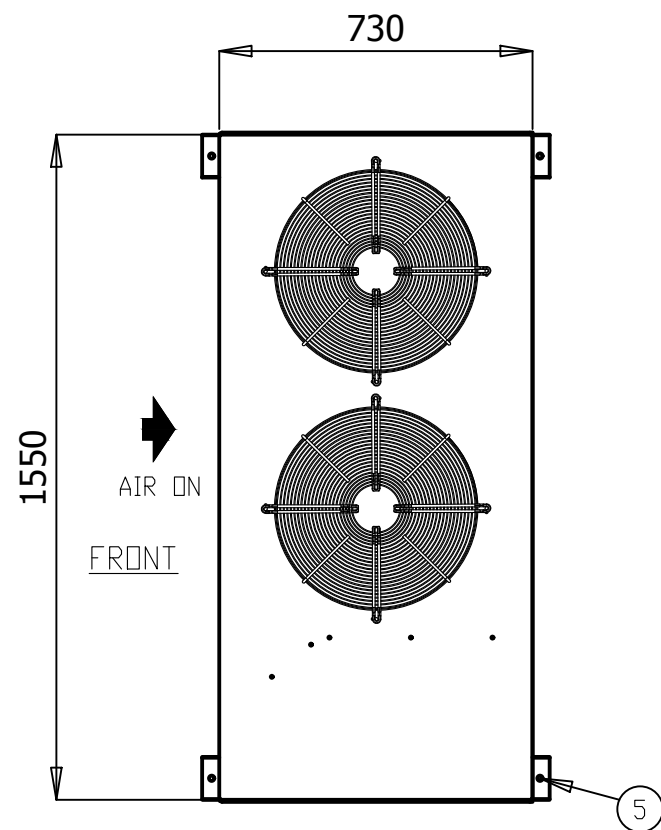

PLAN VIEW

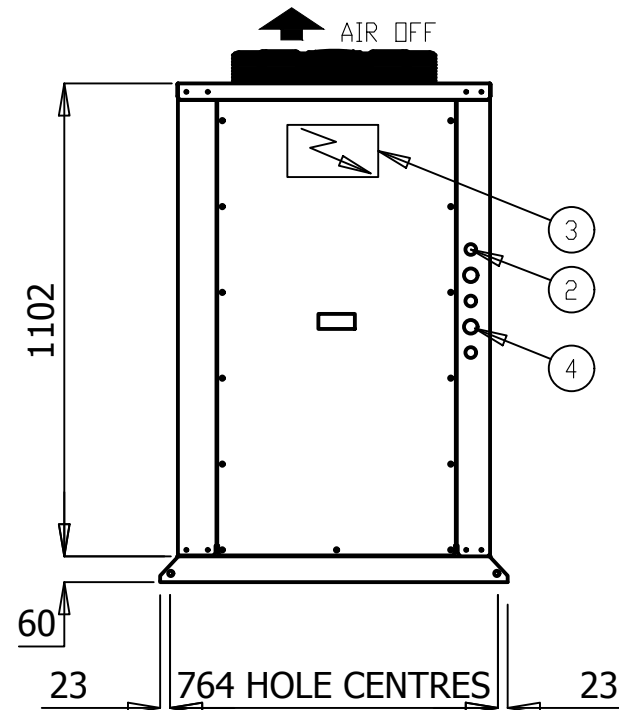

RH ELEVATION

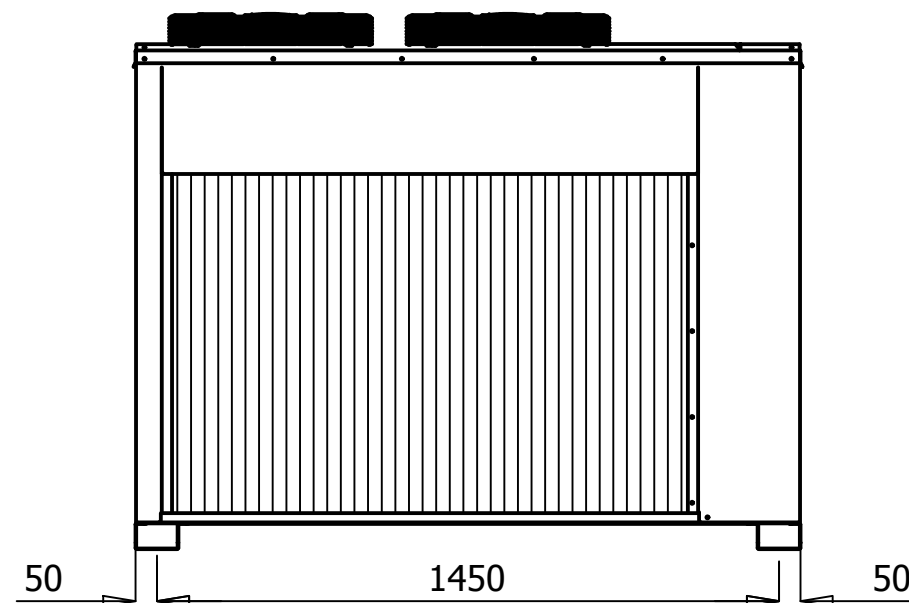

FRONT VIEW

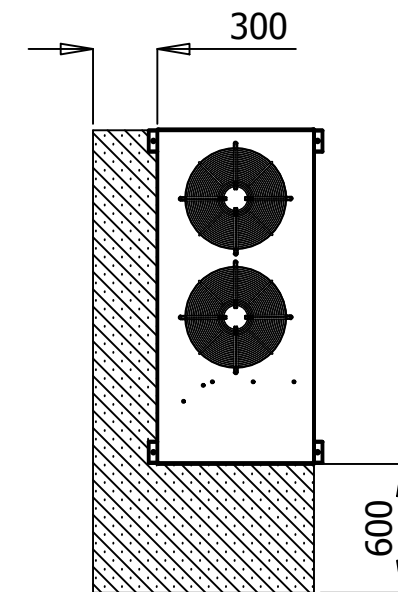

NOTES:

1. GENERAL ARRANGEMENT OF A OUTDOOR SPLIT AIR COOLED VERTICAL UNIT
2. POWER AND FIELD CABLE ENTRIES, 1 x 32 ϕ AND 2 x 25 ϕ
3. ELECTRICAL PANEL LOCATED BEHIND SERVICE ACCESS
4. FIELD PIPE CONNECTIONS
5. UNIT BASE 4 x 16 ϕ FIXING POINTS
6. REFER TO INSTALLATION AND OPERATIONAL MANUAL FOR PIPE SIZING

- ALL DIMENSIONS IN mm.
- GENERAL TOLERANCE ± 1 mm.
- DO NOT SCALE DRAWING.
- MASTER DRAWINGS ARE HELD ELECTRONICALLY. ANY COPY IS DEEMED UNCONTROLLED AND THEREFORE NOT NECESSARILY THE LATEST REVISION.
- ALL INFORMATION REMAINS THE PROPERTY OF THE COMPANY.

GENERAL ARRANGEMENT

S0120VR3SA- S0150VR3SA- S0180VR3SA- S0200VR3SA- S0230VR3SA-

www.apacair.com.au

ABN: 74 005 138 769

	REVISION					REVISED NAMEPLATE WITH APAC DETAILS				
	DRAWN		MT	DRAWING No.		A4				
	DATE		19.07.14	GAD0025						
	SCALE		N.T.S.							
CHECKED		HA	APP'D.	CM	REV.	B				

TECHNICAL DATA SHEET

MODEL NUMBER	Indoor	S012IVR3SA-	S015IVR3SA-	S018IVR3SA-	S020IVR3SA-	S023IVR3SA-	
	Outdoor	S012OVR3SA-	S015OVR3SA-	S018OVR3SA-	S020OVR3SA-	S023OVR3SA-	
MEPS REGISTRATION NUMBER							
		-	-	-	-	-	
OUTDOOR SECTION	CAPACITY						
	Cooling	kW TOTAL*	12.30	15.50	17.50	20.00	22.80
		kW SENSIBLE*	9.42	12.50	13.50	15.30	17.50
		EER (kW / ikW)*	3.52	3.60	3.43	3.39	3.28
	Heating	kW TOTAL	11.90	14.70	16.70	20.60	22.50
		COP	3.66	3.87	3.71	3.81	3.63
	CAPACITY STEPS (%)		0/100	0/100	0/100	0/100	0/100
	COMPRESSOR						
	TYPE		SCROLL	SCROLL	SCROLL	SCROLL	SCROLL
	STARTER TYPE		D.O.L (Opt Soft/Start)	D.O.L (Opt Soft/Start)	D.O.L (Opt Soft/Start)	D.O.L (Opt Soft/Start)	D.O.L (Opt Soft/Start)
	PHASE		3∅	3∅	3∅	3∅	3∅
	No. OFF		1	1	1	1	1
	PROTECTION DEVICES						
	HP SWITCH, LP SWITCH, MOTOR OVERLOAD'S						
	ALL COMPRESSORS HAVE						
	CRANKCASE HEATER						
	FAN						
	TYPE		AXIAL	AXIAL	AXIAL	AXIAL	AXIAL
	ikW (MAX INPUT)		0.19	0.19	0.19	0.27	0.27
	PHASE		1∅	1∅	1∅	1∅	1∅
	No. OFF		2	2	2	2	2
	FAN SPEED CONTROL		VARIABLE SPEED	VARIABLE SPEED	VARIABLE SPEED	VARIABLE SPEED	VARIABLE SPEED
	HEAT EXCHANGER						
	TYPE		PLATE FIN COIL	PLATE FIN COIL	PLATE FIN COIL	PLATE FIN COIL	PLATE FIN COIL
	NOM. AIRFLOW l/s		-	-	-	-	-
REFRIGERANT SYSTEM							
TYPE		R410A					
FACTORY CHARGE PER CIRCUIT (KG)		3.95	5.3	5.7	7.3	6.8	
No. OF CIRCUITS		1	1	1	1	1	
REFRIGERANT CONTROL		TXV					
ALL SYSTEMS INCLUDE							
DRIERS & SIGHT GLASSES							
DIMENSIONS							
H X W X D (mm)		1162 x 730 x 1550					
WEIGHT							
OPERATING KG		211	214	217	220	223	
SHIPPING KG		216	219	222	225	228	
ELECTRICAL							
POWER SUPPLY		415v / 3∅ / 50hz					
FLA / RLA (Amps)		9.7 / 6.5	12 / 7.5	13.5 / 9.1	17.4 / 9.4	17.4 / 10.3	
INDOOR SECTION	FAN						
	TYPE		CENTRIFUGAL	CENTRIFUGAL	CENTRIFUGAL	CENTRIFUGAL	CENTRIFUGAL
	ikW (MAX INPUT)		1.7	1.7	1.7	1.7	1.7
	PHASE		3∅	3∅	3∅	3∅	3∅
	No. OFF		1	1	1	1	1
	FAN SPEED CONTROL		VARIABLE SPEED	VARIABLE SPEED	VARIABLE SPEED	VARIABLE SPEED	VARIABLE SPEED
	HEAT EXCHANGER						
	TYPE		PLATE FIN COIL	PLATE FIN COIL	PLATE FIN COIL	PLATE FIN COIL	PLATE FIN COIL
	NOM. AIRFLOW l/s		625	835	875	990	1120
	EXT STATIC pa		100				
	DIMENSIONS						
	H X W X D (mm)		1580 x 850 x 625			1810 x 850 x 625	
	WEIGHT						
	OPERATING KG		127	131	131	147	147
	SHIPPING KG		130	134	134	150	150
ELECTRICAL							
POWER SUPPLY		415v / 3∅ / 50hz					
FLA / RLA (Amps)		2.6 / 0.5	2.6 / 0.9	2.6 / 0.9	2.6 / 1.0	2.6 / 1.3	
COMBINED SECTIONS	ELECTRICAL						
	H.P. CUT OUT / IN kPa		4500 / 3450	4500 / 3450	4500 / 3450	4500 / 3450	4500 / 3450
	L.P. CUT OUT / IN kPa		175 / 345	175 / 345	175 / 345	175 / 345	175 / 345
	NOM. R.L.A. (TOTAL SYSTEM)		7.0	8.3	10.0	10.4	11.6
	MAX. F.L.A. (TOTAL SYSTEM)		12.3	14.6	16.1	20.0	20.0
	GENERAL						
	CABINET GALVANISED SHEET STEEL						
	INSULATION ALUMINIUM FOIL FACED POLYETHYLENE ACOUSTIC INSULATION						
	EXTERNAL FINISH POLYESTER POWDER COAT - COLOUR LIGHT GREY AS STANDARD - OPTIONS AVAILABLE						
	INDOOR AND OUTDOOR PIPE CONNECTION						
LIQUID mm (inch)		9.5 (3/8")	9.5 (3/8")	9.5 (3/8")	9.5 (3/8")	9.5 (3/8")	
GAS mm (inch)		15.9 (5/8")	19.1 (3/4")	19.1 (3/4")	22.2 (7/8")	22.2 (7/8")	
ADDITIONAL REFRIGERATION CHARGE AND FIELD PIPING CONNECTIONS							
REFER TO INSTALLATION AND OPERATION MANUAL							
NOISE LEVELS <small>[Based on condenser fan's sound data]</small>							
SOUND POWER db(A)		61.7	61.7	61.7	66.6	66.6	

Note:

*Performance excludes ikW of evaporator fan motor.

R.L.A - Run Load Amps are based on current drawn at nominal conditions

F.L.A - Full Load Amps are based on the overload settings [Max Current] of all Compressor and Fan Motor(s).

Date	Document #	Approved By	Revision
1/6/18	TDS0047	CM	B

NOTE: Due to continuous improvement Rinnai Australia Pty Ltd reserve the right to change details without notice.

FAN PERFORMANCE CURVE

S012IVR3SA-

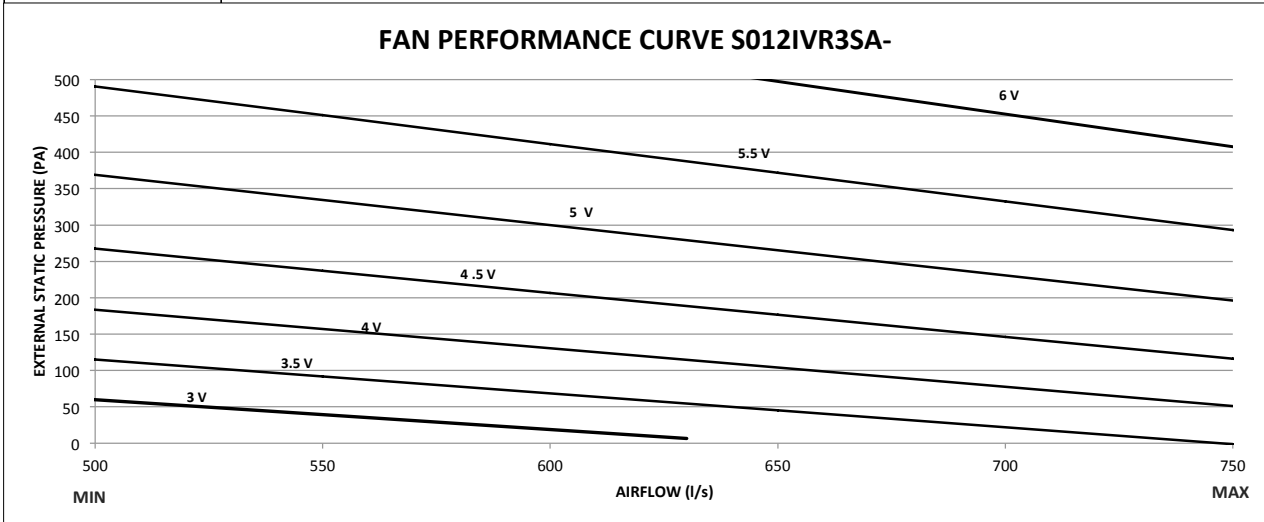

Note:

1. 3V, 3.5V, 4V, 4.5V, 5V, 5.5V and 6V represents potentiometer voltage. Potentiometer can be adjusted to achieve desired flowrates.
2. Potentiometer voltage can be varied infinitely between 0 to 10V.

Date	Document #	Approved By	Revision
30.05.18	FPC0076	CM	B

NOTE: Due to continuous improvement Rinnai Australia Pty Ltd reserve the right to change details without notice.



**HIGH EFFICIENCY
SPLIT DUCTED INDOOR VERTICAL
R410A REFRIGERANT**

SOUND DATA

MODEL NUMBER

S012IVR3SA- / S012OVR3SA-

Outdoor Fan

Sound Power Level dB(A)	Octave band Centre Frequency (hz), dB						
	125	250	500	1k	2k	4k	8k
63.5	69.2	58.6	58.9	58.8	56.8	49.9	47.1

Indoor Fan

Sound Power Level dB(A)	Air Flow (l/s)	Octave band Centre Frequency (hz), dB						
		125	250	500	1k	2k	4k	8k
72.2	625	56.2	65.7	64.5	67.7	66.1	63.3	60.4

Date	Document #	Approved By	Revision
07.06.18	SD0072	CM	B

NOTE: Due to continuous improvement Rinnai Australia Pty Ltd reserve the right to change details without notice.

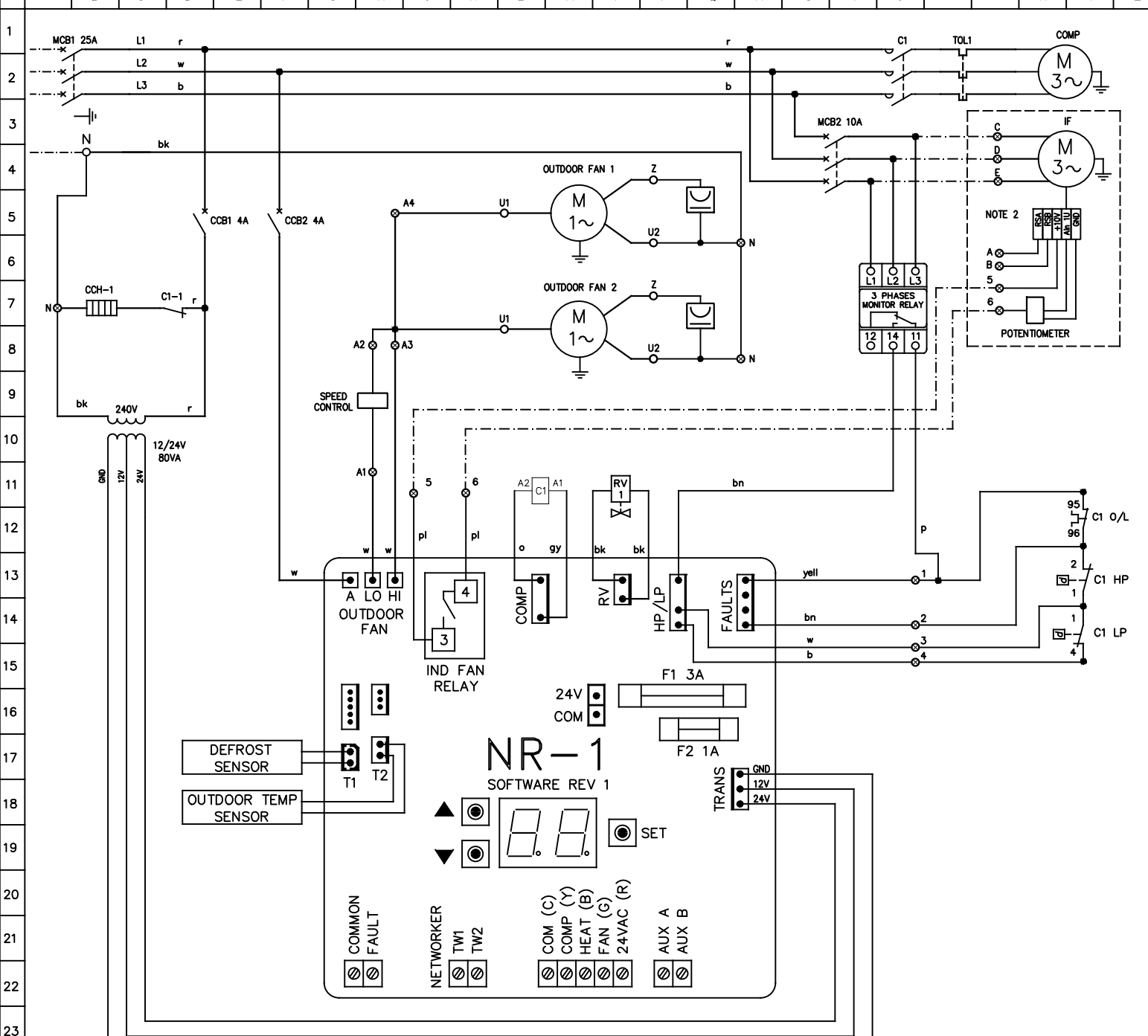

	TYPE	ID	SETTING	
INDOOR FAN OPERATION DURING DEFROST PARAMETER SETTING	INSTALLER	5	1	UPON COMPLETION OF SETTING THE PARAMETERS, SYSTEM (SAFETY SWITCHES, OVERLOADS, LOCKOUT) MUST BE TESTED TO ENSURE CORRECT OPERATION.
		11	1	
FAULT INPUT PARAMETER SETTING	SERVICE	12	0	
		13	0	
		14	1	

- NOTES: 1. THERMAL OVERLOAD RELAYS, HP SWITCH AND LP SWITCH ARE AUTO RESET, UNLESS OTHERWISE STATED.
 2. FOR SPLIT SYSTEMS, OTHERS TO INSTALL ISOLATOR AND FIELD WIRING FOR INDOOR FAN TO INDOOR FAN MOTOR RELAY IN OUTDOOR SECTION.
 3. ALL FIELD WIRING IS THE RESPONSIBILITY OF THE INSTALLING CONTRACTOR, AND MUST COMPLY WITH AS/NZS 3000 AND LOCAL RULES.

WARNING: THE SOFTWARE OF THE NR-1 CONTROLLER IS NOT DESIGNED TO FUNCTION AS A PRIMARY PERSONAL SAFETY DEVICE, AS CONNECTED EQUIPMENT CAN START AUTOMATICALLY WITHOUT WARNING. ALSO OPENING THERMOSTAT CONTACTS OR SWITCHING OFF ON THE NC4 NETWORKER MAY NOT CAUSE THE EQUIPMENT TO STOP. THE ELECTRONIC CONTROLLER HAS A BUILT IN AUTOMATIC RESET FAULT LOCKOUT FUNCTION AND MAY RESTART THE SYSTEM AUTOMATICALLY WITHOUT WARNING.
 OUTDOOR FAN MOTORS HAVE INTERNAL OVERLOADS AND MAY RESTART AUTOMATICALLY.

IMPORTANT NOTE: THE SCROLL COMPRESSOR IS ROTATIONALLY SENSITIVE, IF NOISY OR NOT PUMPING, CHANGE ANY OF TWO PHASES.

LEGEND		LEGEND		COLOUR CODE	COMPRESSOR (EACH)	MODEL: S0120VR3SA-V	
COMP	COMPRESSOR CONTACTOR	---	FIELD WIRING	r	kW 2.83	OPTIONS	
O/L	THERMAL OVERLOAD	---	MAINS/CONTROL WIRING	w			RATED CURRENT 8.00
TOL	CRANK CASE HEATER	---	CONTROL PARAMETER	b	O/L SETTING 8.80	A	
CCH	REVERSING VALVE	⊗	SWITCHBOARD TERMINAL	bk	FANS (EACH)	STANDARD	
RV1	HIGH PRESSURE SWITCH	○	TERMINAL	bn	kW	FLA	
HP	LOW PRESSURE SWITCH			o	OUTDOOR	0.19	0.86
LP	MINIATURE CIRCUIT BREAKER			p	INDOOR	1.70	2.60
MCB	CONTROL CIRCUIT BREAKER			pl			
CCB	CONTROL CIRCUIT BREAKER			gy			
				yell			

apac
by Rimini

DATE	17/06/2018		
DWN	S.P	APPD	ENG
REV	A	GRID	B195
DWG No.	EWS02173		