



**HPU HANDING CONFIRMATION**

<b>SO NUMBER</b> (INTERNAL USE)		<b>WO NUMBER</b> (INTERNAL USE)	
------------------------------------	--	------------------------------------	--

**ROOF TOP PACKAGED UNITS (RTU)**

<b>MODELS</b>	All
<b>GENERAL</b>	This document details the airside configurations available on all HPU models.
<b>SOURCING</b>	Standard configuration is detailed in the unit general arrangement drawings. Optional airside configurations to be specified at time of order.
<b>HOW TO USE THIS DOCUMENT</b>	<ol style="list-style-type: none"> <li>1. Choose if the supply air fan position is required on the left or right.</li> <li>2. Circle the required supply air outlet.</li> <li>3. Circle the required return air inlet.</li> <li>4. Complete the information at the bottom of this document and return to your APAC representative.</li> </ol>

LEFT HAND SUPPLY AIR (STANDARD)	RIGHT HAND SUPPLY AIR (OPTIONAL)
---------------------------------	----------------------------------

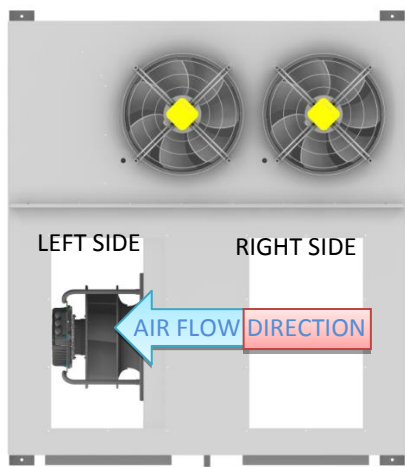

Fig1. Left hand unit from the top view

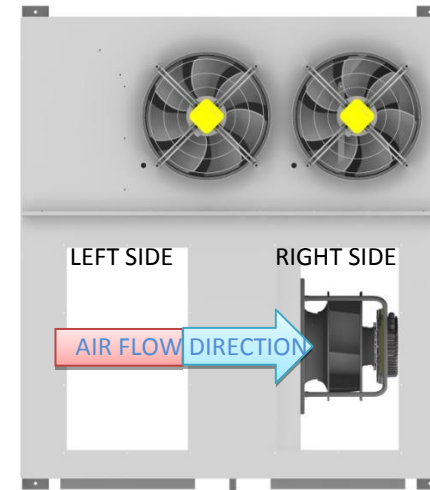

Fig3. Right hand unit from top view

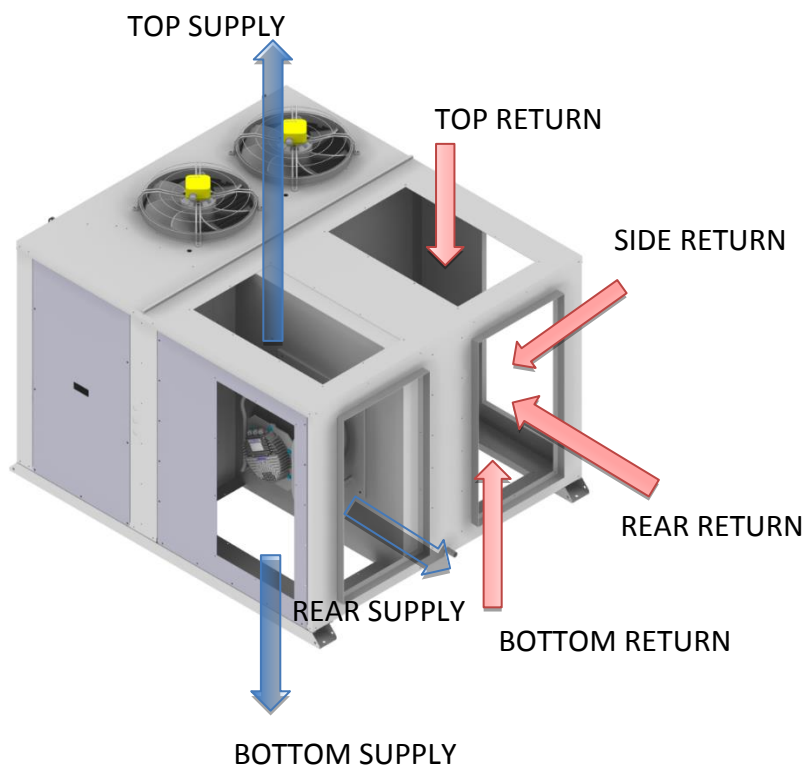

Fig2. Air flow schematic of the left hand unit

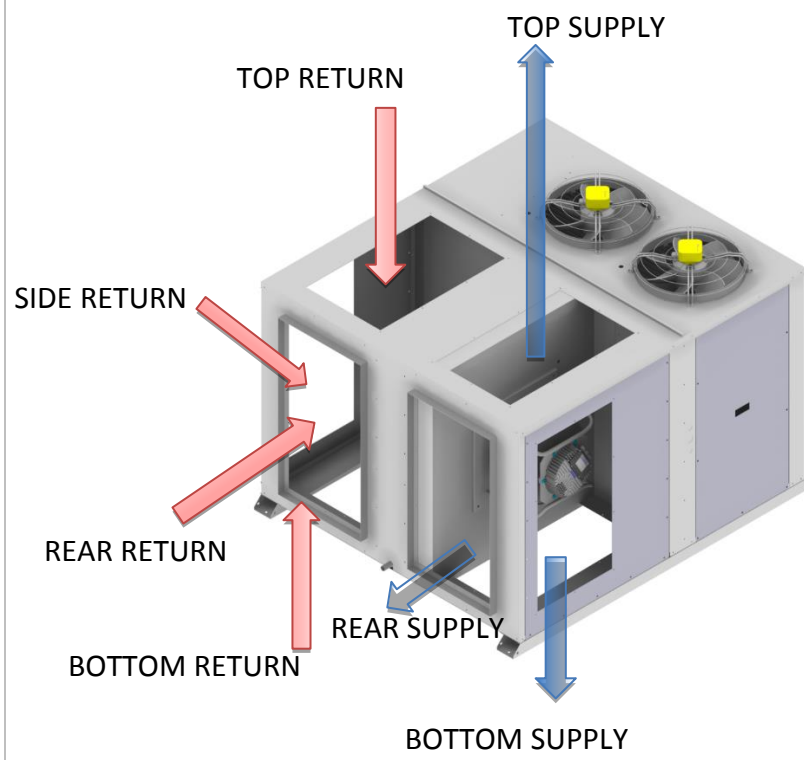
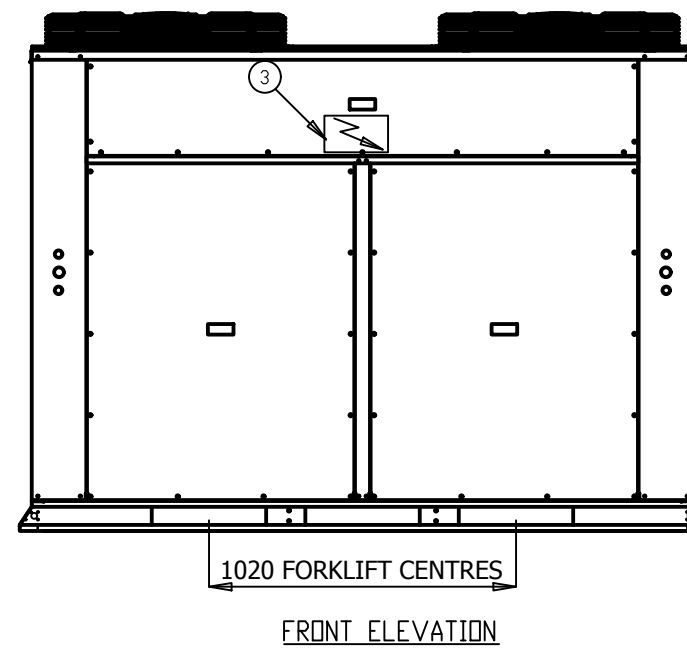
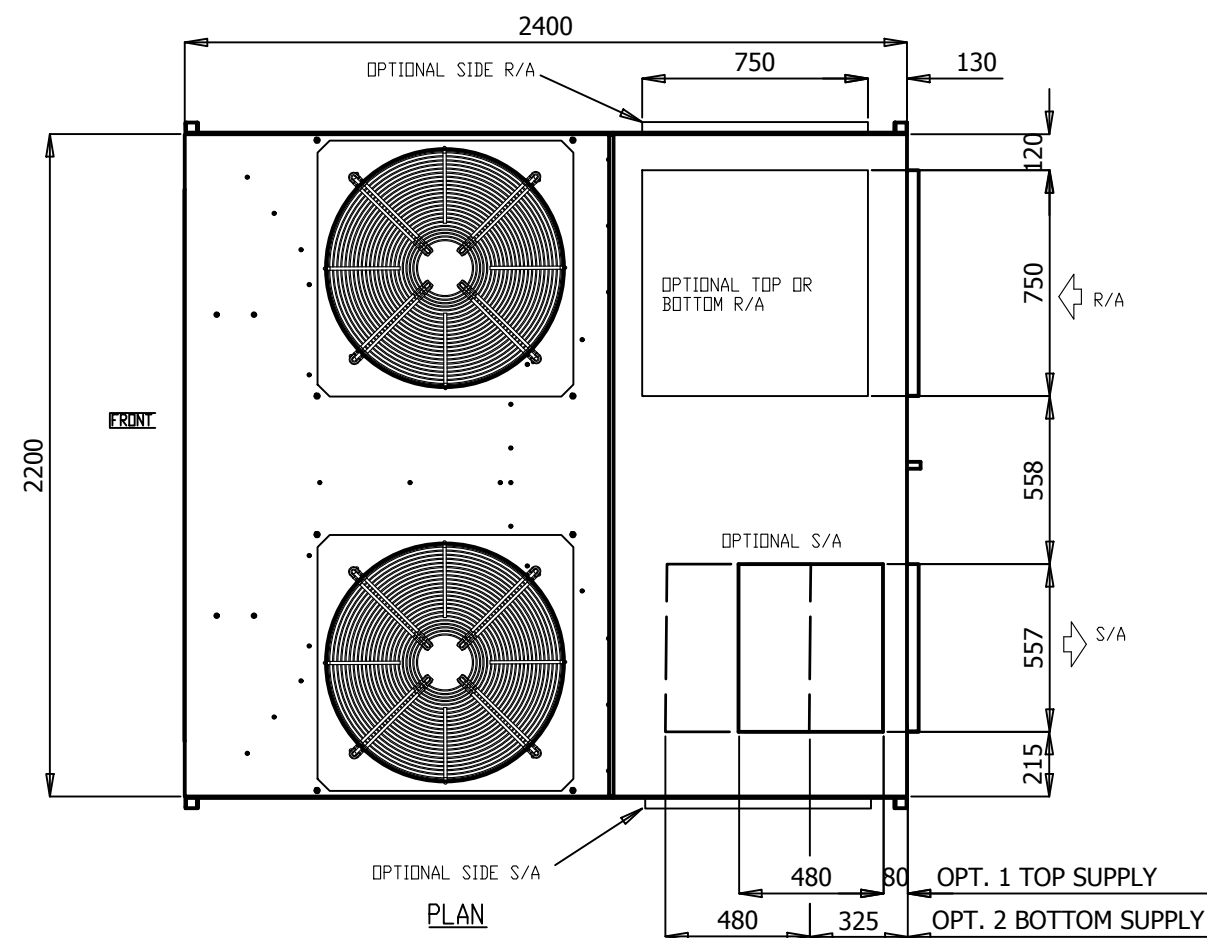

Fig 4. Air flow schematic of the right hand unit

**CUSTOMER TO COMPLETE AND RETURN**

CUSTOMER	PROJECT	UNIT REF	NAME / SIGN	DATE



**NOTES:**

1. GENERAL ARRANGEMENT OF A HORIZONTAL AIR COOLED PACKED UNIT
2. POWER AND FIELD CABLE ENTRIES, 1 x 32 $\phi$  AND 2 x 25 $\phi$
3. ELECTRICAL PANEL LOCATED BEHIND SERVICE ACCESS
4. CONDENSATE OUTLET 25 $\phi$
5. UNIT BASE 4 x 16 $\phi$  FIXING POINTS
6. UNIT HAS 4 x 20 $\phi$  LIFTING POINTS
7. UNIT CONFIGURATION AS STANDARD IS REAR LEFT SUPPLY, REAR RIGHT RETURN, OTHER CONFIGURATIONS AVAILABLE.
8. UNIT CONFIGURATION CAN BE CONVERTED IN FIELD WITH OPTIONAL ACCESSORIES.

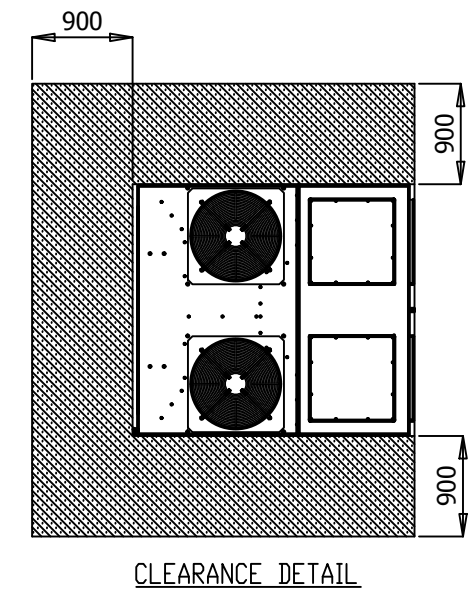
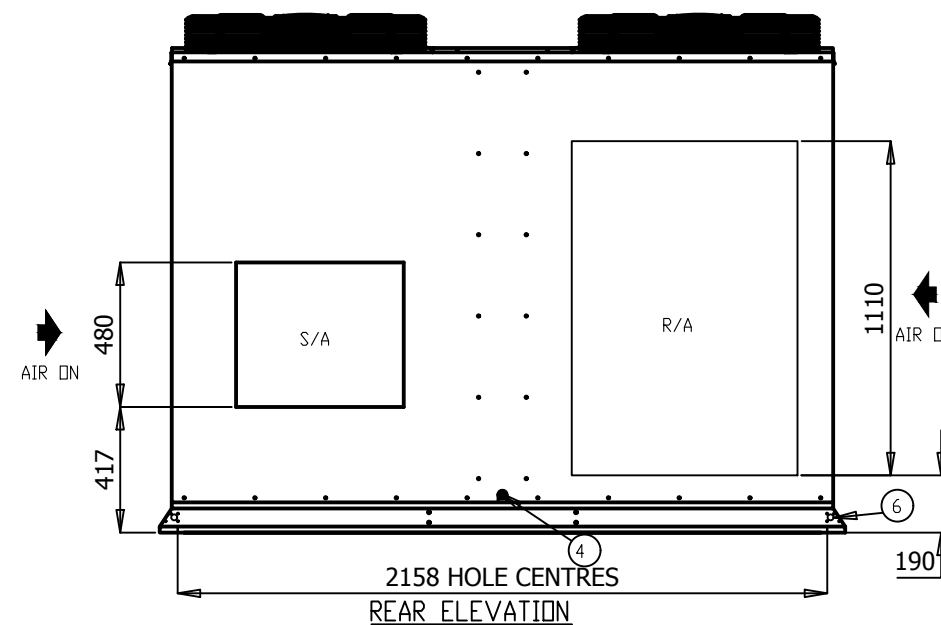
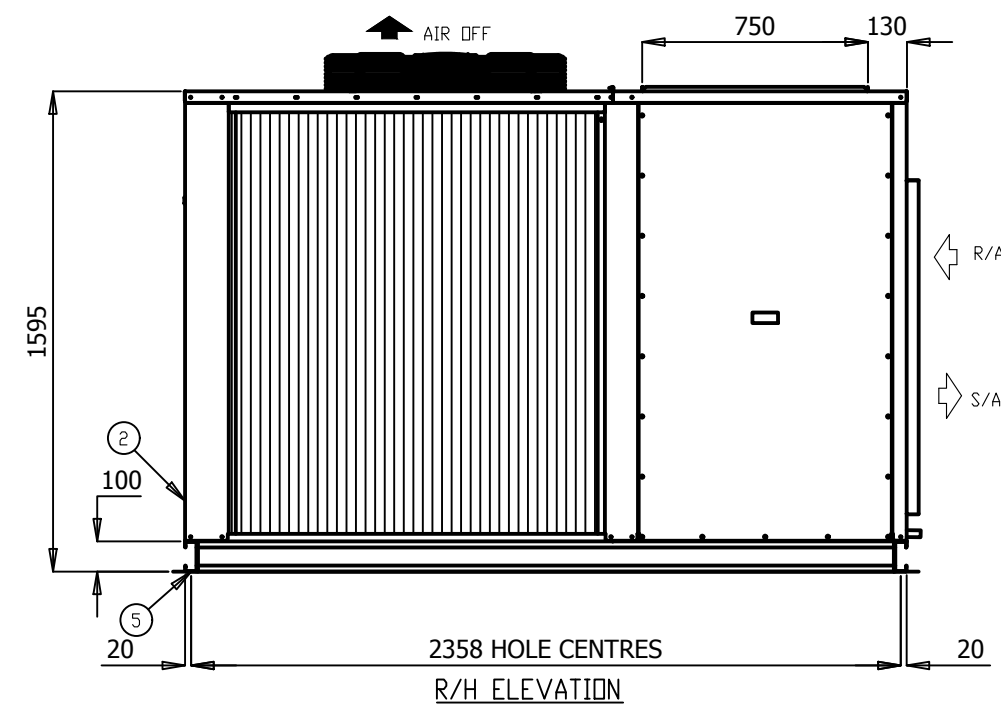

- ALL DIMENSIONS IN mm.
- GENERAL TOLERANCE  $\pm 1$ mm.
- DO NOT SCALE DRAWING.
- MASTER DRAWINGS ARE HELD ELECTRONICALLY. ANY COPY IS DEEMED UNCONTROLLED AND THEREFORE NOT NECESSARILY THE LATEST REVISION.
- ALL INFORMATION REMAINS THE PROPERTY OF THE COMPANY.

**GENERAL ARRANGEMENT**

P065AHR3SA-

www.apacair.com.au

ABN: 74 005 138 769

**REVISION**



**REVISED NAMEPLATE WITH APAC DETAILS**

DRAWN	MT	DRAWING No.	A4
DATE	13.07.17	<b>GAD0086</b>	
SCALE	N.T.S.	APP'D.	CM
CHECKED	HA	REV.	B

# TECHNICAL DATA SHEET

MODEL NUMBER		P055AHR3SA-	P065AHR3SA-	P075AHR3SA-	P085AHR3SA-	P095AHR3SA-	
MEPS REGISTRATION NUMBER		AAC3206	AAC3215	N/A	N/A	N/A	
<b>CONDENSER SECTION</b>	<b>CAPACITY</b>						
	<b>Cooling</b>	kW TOTAL*	52.98	63.89	72.95	83.74	94.04
		kW SENSIBLE*	44.29	54.50	58.51	69.34	77.49
		EER (kW / ikW)*	3.06	3.28	3.49	3.47	3.24
	<b>Heating</b>	kW TOTAL	54.40	65.00	73.40	84.30	96.08
		COP	3.40	3.61	3.59	3.60	3.60
	CAPACITY STEPS (%)		50/100	50/100	50/100	50/100	50/100
	<b>COMPRESSOR</b>						
	TYPE		SCROLL	SCROLL	SCROLL	SCROLL	SCROLL
	STARTER TYPE		D.O.L (Opt Soft/Start)	D.O.L (Opt Soft/Start)	D.O.L (Opt Soft/Start)	D.O.L (Opt Soft/Start)	D.O.L (Opt Soft/Start)
	PHASE		3Ø	3Ø	3Ø	3Ø	3Ø
	No. OFF		2	2	2	2	2
	PROTECTION DEVICES		HP SWITCH, LP SWITCH, MOTOR OVERLOAD'S				
	ALL COMPRESSORS HAVE		CRANKCASE HEATER				
	<b>FAN</b>						
	TYPE		AXIAL	AXIAL	AXIAL	AXIAL	AXIAL
	ikW (MAX INPUT)		0.97	0.93	0.93	0.93	0.93
	PHASE		3Ø	3Ø	3Ø	3Ø	3Ø
	No. OFF		2	2	2	2	2
	FAN SPEED CONTROL		VARIABLE SPEED	VARIABLE SPEED	VARIABLE SPEED	VARIABLE SPEED	VARIABLE SPEED
<b>HEAT EXCHANGER</b>							
TYPE		PLATE FIN COIL	PLATE FIN COIL	PLATE FIN COIL	PLATE FIN COIL	PLATE FIN COIL	
NOM. AIRFLOW l/s		-	-	-	-	-	
<b>REFRIGERANT SYSTEM</b>							
TYPE		<b>R410A</b>					
CHARGE PER CIRCUIT (KG)		5.75	6.75	9.5	11	10.8	
No. OF CIRCUITS		2	2	2	2	2	
REFRIGERANT CONTROL		TXV					
ALL SYSTEMS INCLUDE		DRIERS & SIGHT GLASSES					
<b>EVAPORATOR SECTION</b>	<b>FAN</b>						
	TYPE		CENTRIFUGAL	CENTRIFUGAL	CENTRIFUGAL	CENTRIFUGAL	CENTRIFUGAL
	ikW (MAX INPUT)		3	2.73	2.73	2.82	2.82
	PHASE		3Ø	3Ø	3Ø	3Ø	3Ø
	No. OFF		1	2	2	2	2
	FAN SPEED CONTROL		VARIABLE SPEED	VARIABLE SPEED	VARIABLE SPEED	VARIABLE SPEED	VARIABLE SPEED
	<b>HEAT EXCHANGER</b>						
TYPE		PLATE FIN COIL	PLATE FIN COIL	PLATE FIN COIL	PLATE FIN COIL	PLATE FIN COIL	
NOM. AIRFLOW l/s		2880	3550	3750	4400	4930	
EXT STATIC pa		100					
<b>COMBINED SECTIONS</b>	<b>ELECTRICAL</b>						
	MAINS POWER		415v / 3Ø / 50hz	415v / 3Ø / 50hz	415v / 3Ø / 50hz	415v / 3Ø / 50hz	415v / 3Ø / 50hz
	H.P. CUT OUT / IN kPa		4500 / 3450	4500 / 3450	4500 / 3450	4500 / 3450	4500 / 3450
	L.P. CUT OUT / IN kPa		175 / 345	175 / 345	175 / 345	175 / 345	175 / 345
	NOM. R.L.A. (TOTAL SYSTEM)		31.1	35.5	38.1	43.6	56.4
	MAX. F.L.A. (TOTAL SYSTEM)		49.8	55.4	61.4	73.6	79.6
	<b>GENERAL</b>						
	CABINET		GALVANISED SHEET STEEL				
	INSULATION		ALUMINIUM FOIL FACED POLYETHYLENE ACOUSTIC INSULATION				
	EXTERNAL FINISH		POLYESTER POWDER COAT - COLOUR LIGHT GREY AS STANDARD - OPTIONS AVAILABLE				
	<b>DIMENSIONS</b>						
	H X W X D (mm)		1390 x 1850 x 2400	1595 x 2200 x 2400		1800 x 2200 x 2750	
	<b>WEIGHT</b>						
OPERATING KG		730	900	920	1060	1070	
SHIPPING KG		735	905	925	1065	1075	
<b>NOISE LEVELS [Based on condenser fan's sound data]</b>							
Sound Power db(A)		70.9	71.5	71.5	71.5	71.5	

**Note:** Rated in accordance with Australian standard AS/NZS 3823.1:2012  
Performance excludes ikW of evaporator fan motor.  
R.L.A - Run Load Amps are based on current drawn at nominal conditions  
F.L.A - Full Load Amps are based on the overload settings [Max Current] of all Compressor and Fan Motor(s).

Date	Document #	Approved By	Revision
31/05/18	TDS0018	CM	D

**NOTE:** Due to continuous improvement Rinnai Australia Pty Ltd reserve the right to change details without notice.

## FAN PERFORMANCE CURVE

**P065AHR3SA-**

**FAN PERFORMANCE CURVE P065AHR3SA-**

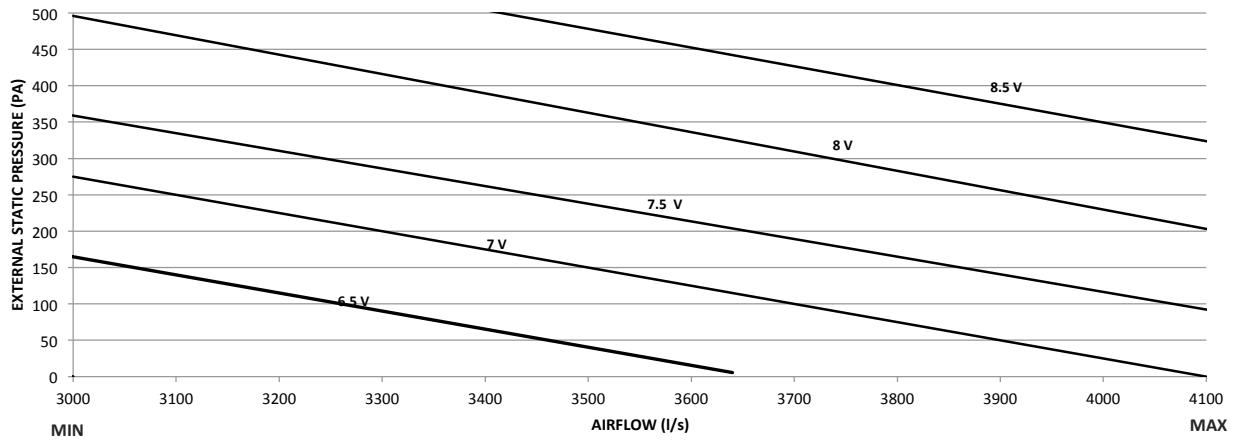

Note:

1. 5.5V, 6.5V, 7V, 7.5V, 8V and 8.5V represents potentiometer voltage. Potentiometer can be adjusted to achieve desired flowrates.
2. Potentiometer voltage can be varied infinitely between 0 to 10V.

Date	Document #	Approved By	Revision
28.05.18	FPC0019	CM	D

**NOTE: Due to continuous improvement Rinnai Australia Pty Ltd reserve the right to change details without notice.**



## **SOUND DATA**

**MODEL NUMBER**

**P065AHR3SA-**

### **Outdoor Fan**

Sound Power Level dB(A)	Octave band Centre Frequency (Hz), dB						
	125	250	500	1k	2k	4k	8k
71.5	73.9	68.9	66.5	64.6	65.7	62	58.4

### **Indoor Fan**

Sound Power Level dB(A)	Air Flow (l/s)	Octave band Centre Frequency (Hz), dB						
		125	250	500	1k	2k	4k	8k
82.8	3550	65.4	74.9	77.8	78.6	74.3	74	73.4

Date	Document #	Approved By	Revision
31.05.18	SD0010	CM	B

**NOTE: Due to continuous improvement Rinnai Australia Pty Ltd reserve the right to change details**

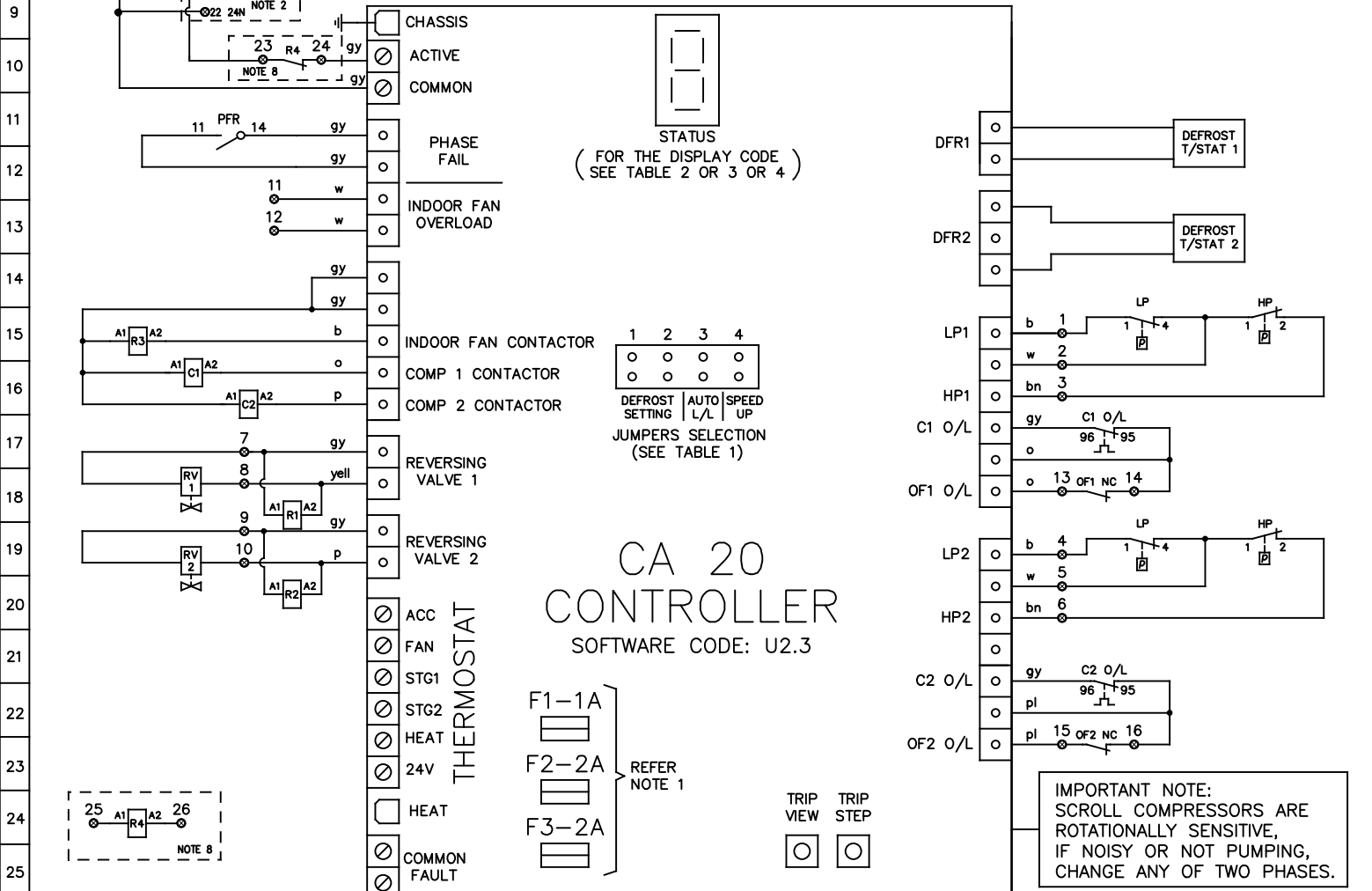
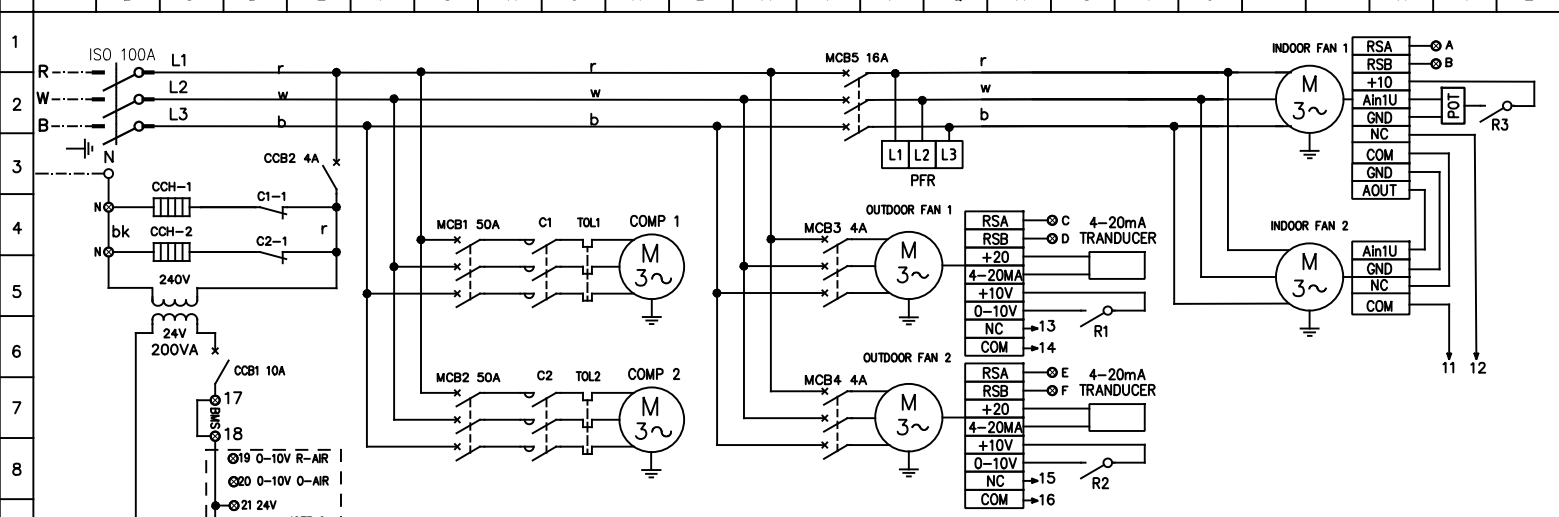

**WARNING!** THE SOFTWARE OF THE CA20 CONTROLLER IS NOT DESIGNED TO FUNCTION AS A PRIMARY PERSONAL SAFETY DEVICE, AS CONNECTED EQUIPMENT CAN START AUTOMATICALLY WITHOUT WARNING. ALSO, OPENING THERMOSTAT CONTACTS MAY NOT CAUSE THE EQUIPMENT TO STOP. OUTDOOR FAN MOTORS HAVE INTERNAL OVERLOADS AND MAY RESTART AUTOMATICALLY.

NOTES:

- TIME DELAY GLASS FUSES ON THE PCB CONTROLLER ARE THE FOLLOWING:
  - F1 PROTECTS THE THERMOSTAT CIRCUIT.
  - F2 PROTECTS THE REVERSING VALVE CIRCUITS AND THE "HEAT" OUTPUT. THIS FUSE F2 ALSO SUPPLIES FUSE F1.
  - F3 PROTECTS BOTH COMPRESSOR CONTACTOR CIRCUITS AND THE INDOOR FAN CONTACTOR CIRCUIT.
- OPTIONAL 24VAC POWER SUPPLY AND 0-10V TERMINALS FOR ECONOMY CYCLE DAMPER MOTORS
- HP CUT OUT , LP CUT OUT - AUTO RESET.
- THERMAL OVERLOAD RELAYS - AUTO RESET, UNLESS OTHERWISE STATED.
- DO NOT CONNECT ANY ADDITIONAL EQUIPMENT TO THE CONTROL TRANSFORMER OTHER THAN THE EQUIPMENT SHOWN ON THE ELECTRICAL DRAWING.
- ALL FIELD WIRING IS THE RESPONSIBILITY OF THE INSTALLING CONTRACTOR AND MUST COMPLY WITH AS/NZS 3000 AND LOCAL RULES.
- SOFTWARE CODE MUST BE CHECKED AFTER REPLACEMENT OF THE CA-20 CONTROLLER BY CHECKING THE DISPLAY CODE ON THE 7 SEGMENT DISPLAY AFTER THE CONTROLLER IS ACTIVATED.
- OPTIONAL FIRE ALARM RELAY

JUMPERS SELECTION	DEFROST INTERVAL TIME SETTING	JUMPERS SELECTION	AUTO LEAD/LAG	JUMPERS SELECTION	SPEED UP
1 2 ○ ○	15 min	3 ○	OFF	4 ○	OFF
1 2 ■ ○	FACTORY SETTING 30 min	3 ■	ON	4 ■	ON
1 2 ■ ■	45 min	3 ■	ON	4 ■	ON

UNIT MUST BE SWITCHED OFF BEFORE CHANGING THE JUMPER SELECTION

LEGEND		LEGEND		COLOUR CODE	COMPRESSOR (EACH)		MODEL: P065AHR3SA
○	TERMINAL SWITCHBOARD	TOL	THERMAL OVERLOAD RELAY	r	RED	KW	7.83
⊗	TERMINAL	R	RELAY	w	WHITE	RATED CURRENT	22.00
- - -	FIELD WIRING	C	CONTACTOR	b	BLUE	O/L SETTING	24.20
- - -	CONTROL PARAMETER	COMP	COMPRESSOR	bk	BLACK	FANS (EACH) KW	FLA
- - -	MAINS/CONTROL WIRING	ISO	ISOLATOR SWITCH	bn	BROWN	OUTDOOR	0.93
- - -	WIRING	MCB	MINIATURE CIRCUIT BREAKER	o	ORANGE	INDOOR	1.50
CCH	CRANK CASE HEATER	CCB	CONTROL CIRCUIT BREAKER	p	PINK		
PFR	PHASE FAILURE RELAY	CCB	CONTROL CIRCUIT BREAKER	pl	PURPLE		
RV	REVERSING VALVE	O/L	OVERLOAD	gy	GREY		
HP	HIGH PRESSURE SWITCH	POT	POTENTIOMETER	yell	YELLOW		
LP	LOW PRESSURE SWITCH						

**apac**  
by Riinnai

DATE: 7/07/2018

DWN: S.P APPD ENG

REV: A GRID B68

DWG No. EWS02065