



VPU HANDING CONFIRMATION

DO NUMBER (INTERNAL USE)	WO NUMBER (INTERNAL USE)
-----------------------------	-----------------------------

VERTICAL PACKAGED UNITS (VPU)

MODELS	P024-045AVR3SA-
GENERAL	This document details the airside configurations available on 024-045 VPU models.
SOURCING	Standard configuration is LTR. Optional airside configurations to be specified at time of order.
HOW TO USE THIS DOCUMENT	<ol style="list-style-type: none"> 1. Choose if the supply air fan position is required on the left or right. 2. Circle the required supply air outlet. 3. Circle the required return air inlet. 4. Complete the information at the bottom of this document and return to your APAC representative.

LTR – TOP LEFT SUPPLY / REAR LEFT RETURN
(REPLACEMENT FOR FRIGIPOL & APAC S25, 30, 35, 45)

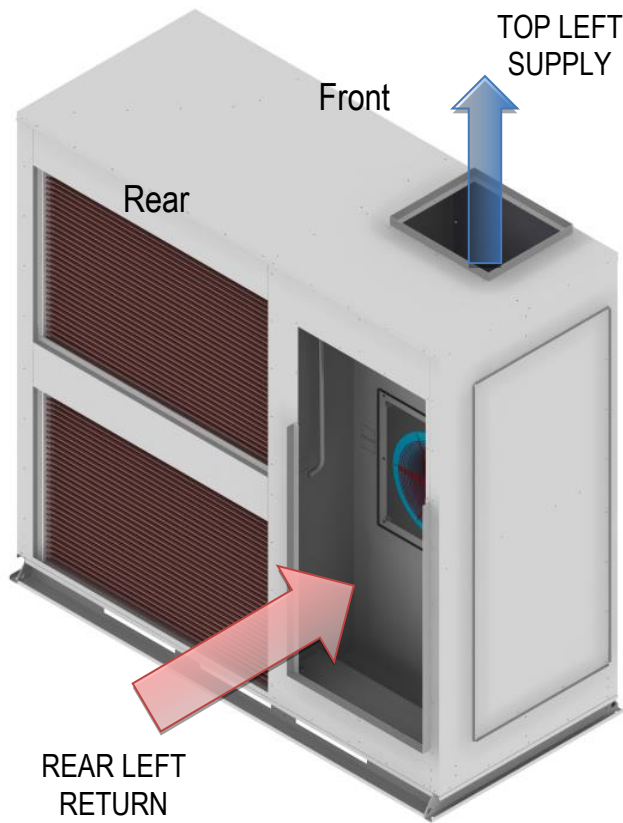

RTR – TOP RIGHT SUPPLY / REAR RIGHT RETURN
(REPLACEMENT FOR FRIGIPOL & APAC S25, 30, 35, 45)

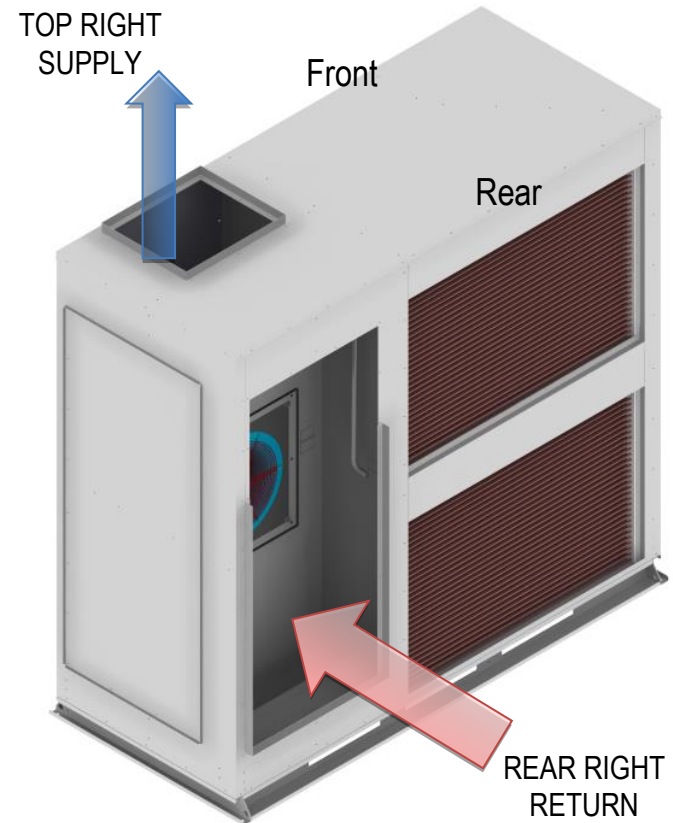

LTS – TOP LEFT SUPPLY / SIDE LEFT RETURN
(REPLACEMENT FOR FRIGIPOL & APAC S25, 30, 35, 45)

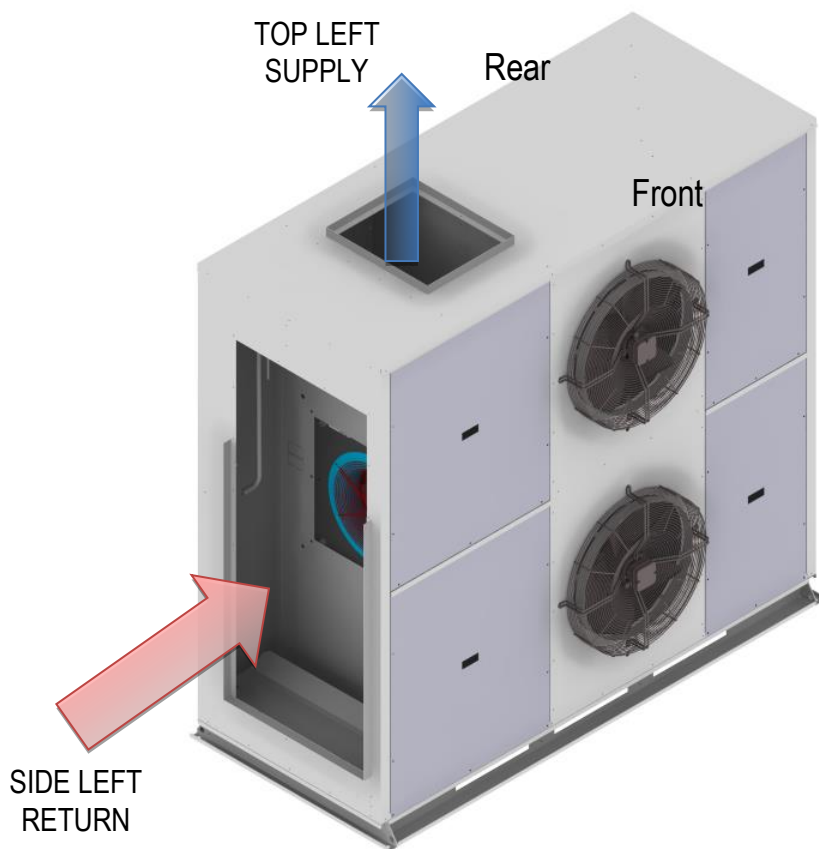

RTS – TOP RIGHT SUPPLY / SIDE RIGHT RETURN
(REPLACEMENT FOR FRIGIPOL & APAC S25, 30, 35, 45)

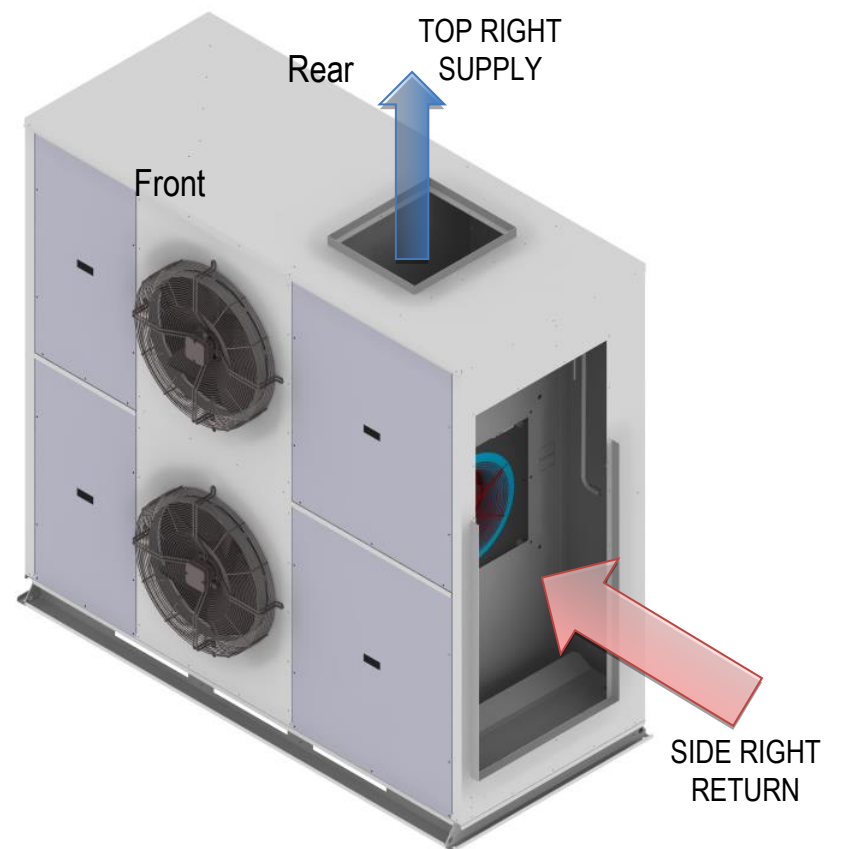

CUSTOMER TO COMPLETE AND RETURN

CUSTOMER	PROJECT	UNIT REF	NAME / SIGN	DATE

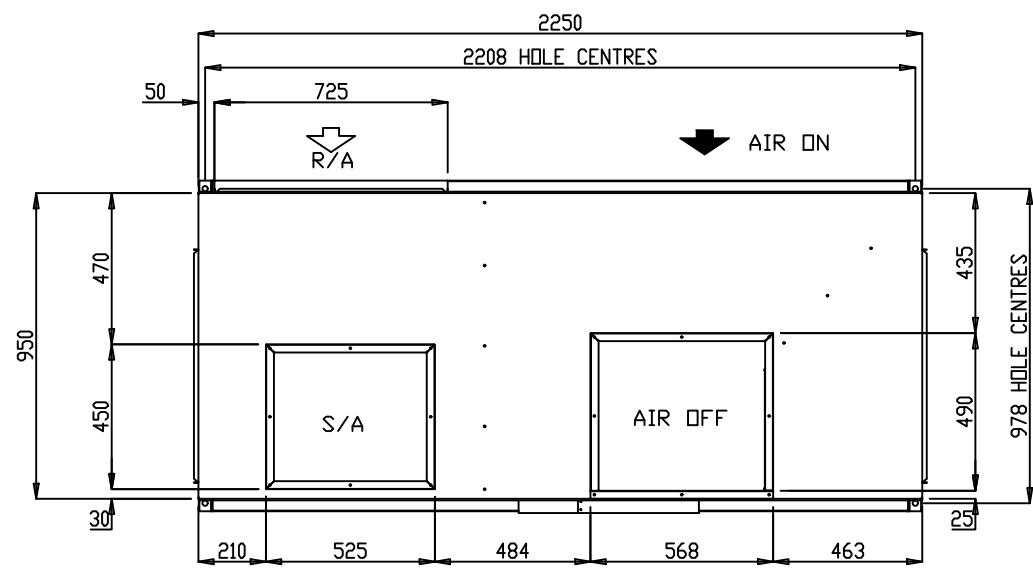

PLAN

DIMENSION	P024-035	P040-045
A	1145	1600
B	700	245

- NOTES:**
1. GENERAL ARRANGEMENT OF A VERTICAL AIR COOLED PACKED UNIT
 2. POWER AND FIELD CABLE ENTRIES, 1 x 32 ϕ AND 2 x 25 ϕ (BOTH SIDES)
 3. ELECTRICAL PANEL LOCATED BEHIND SERVICE ACCESS
 4. CONDENSATE OUTLET 25 ϕ
 5. UNIT BASE 4 x 16 ϕ FIXING POINTS
 6. UNIT HAS 4 x 25.4 ϕ LIFTING POINTS
 7. UNIT CONFIGURATION IS TOP LEFT SUPPLY, REAR LEFT RETURN.

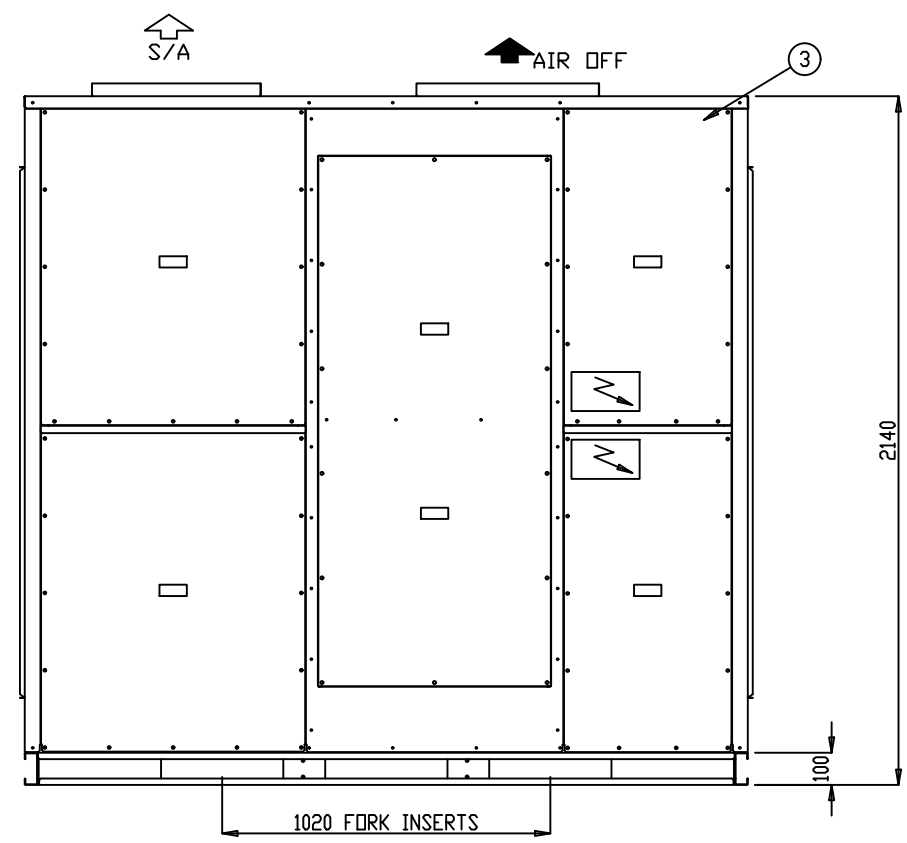

FRONT ELEVATION

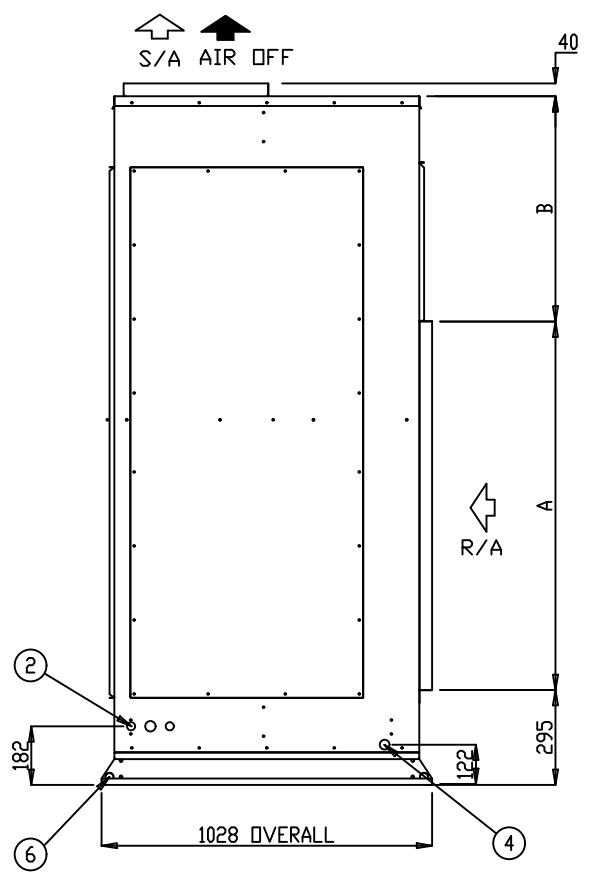

R/H ELEVATION

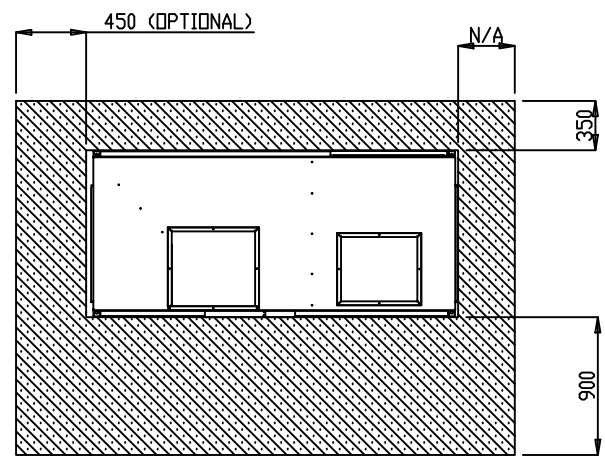

CLEARANCE DETAIL

- ALL DIMENSIONS IN mm.
- GENERAL TOLERANCE ± 1 mm.
- DO NOT SCALE DRAWING.
- MASTER DRAWINGS ARE HELD ELECTRONICALLY. ANY COPY IS DEEMED UNCONTROLLED AND THEREFORE NOT NECESSARILY THE LATEST REVISION.
- ALL INFORMATION REMAINS THE PROPERTY OF THE COMPANY.

GENERAL ARRANGEMENT

P024AVR3SA-LTR-U P030AVR3SA-LTR-U
 P035AVR3SA-LTR-U P040AVR3SA-LTR-U
 P045AVR3SA-LTR-U

www.apacair.com.au

ABN: 74 005 138 769

REVISION	REVISED NAMEPLATE WITH APAC DETAILS				
 ATLANTIC DR. KEYSBOROUGH VIC 3173 1300 555 545 by Rinnai	DRAWN	MT	DRAWING No.	A4	
	DATE	07.03.14	GAD0014		
	SCALE	N.T.S.			
	CHECKED	HA	APP'D.	CM	REV.

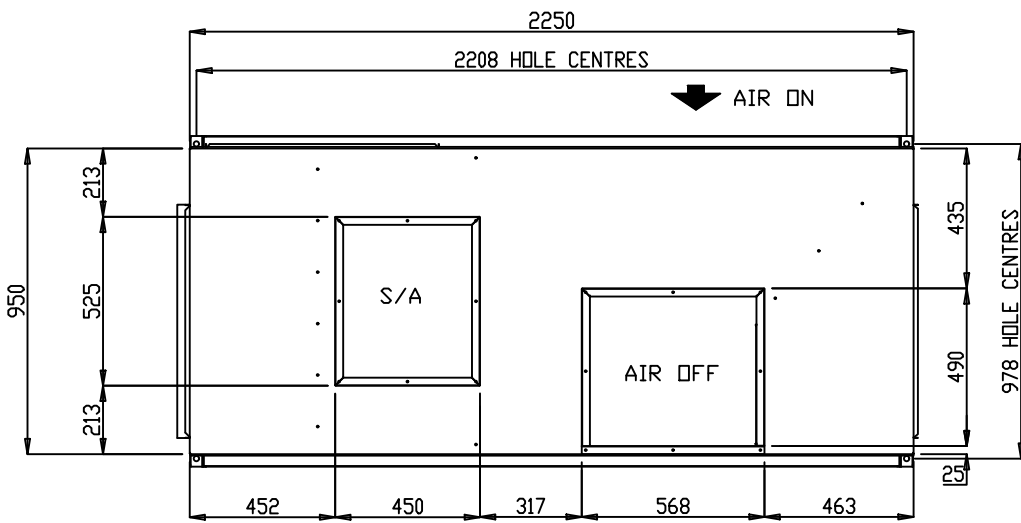

FRONT
PLAN

DIMENSION	APH024-035	APH040-045
A	1145	1600
B	700	245

- NOTES:
1. GENERAL ARRANGEMENT OF A VERTICAL AIR COOLED PACKED UNIT
 2. POWER AND FIELD CABLE ENTRIES, 1 x 32 ϕ AND 2 x 25 ϕ (BOTH SIDES)
 3. ELECTRICAL PANEL LOCATED BEHIND SERVICE ACCESS
 4. CONDENSATE OUTLET 25 ϕ
 5. UNIT BASE 4 x 16 ϕ FIXING POINTS
 6. UNIT HAS 4 x 25.4 ϕ LIFTING POINTS
 7. UNIT CONFIGURATION IS TOP LEFT SUPPLY, SIDE LEFT RETURN.

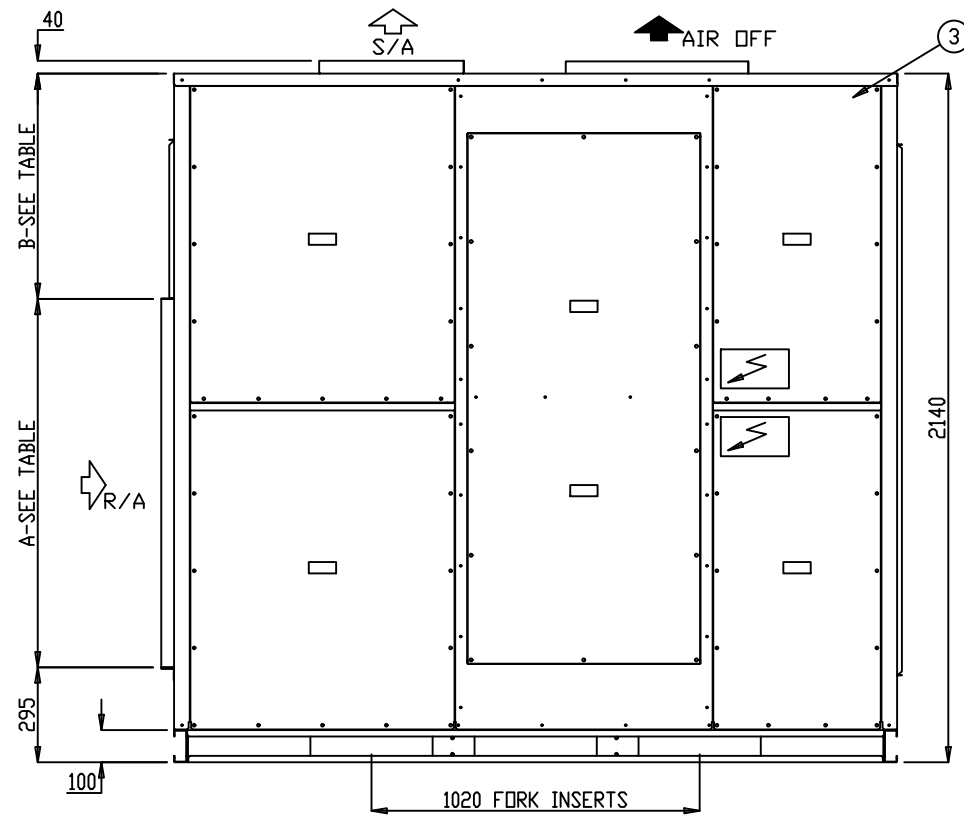

FRONT ELEVATION

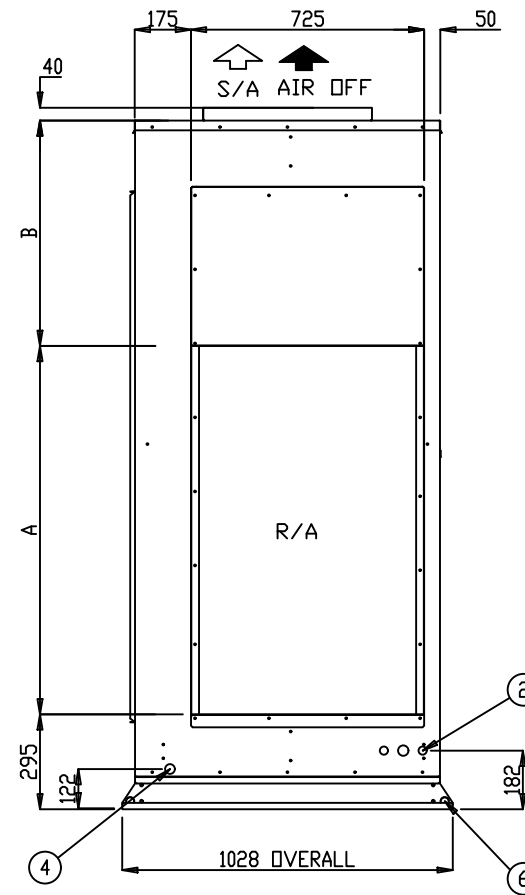

L/H ELEVATION

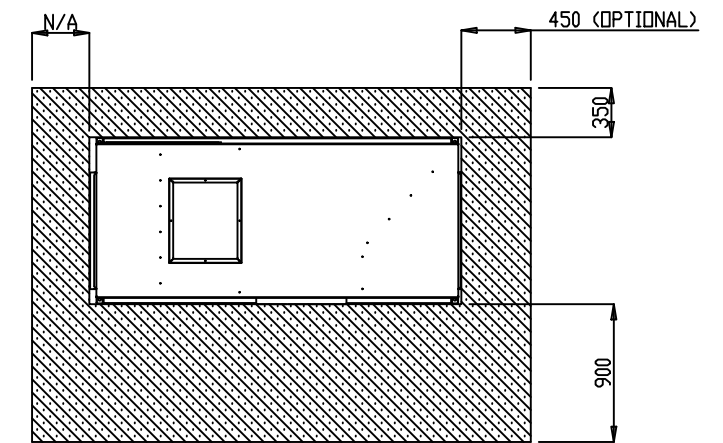

CLEARANCE DETAIL

- ALL DIMENSIONS IN mm.
- GENERAL TOLERANCE ± 1 mm.
- DO NOT SCALE DRAWING.
- MASTER DRAWINGS ARE HELD ELECTRONICALLY. ANY COPY IS DEEMED UNCONTROLLED AND THEREFORE NOT NECESSARILY THE LATEST REVISION.
- ALL INFORMATION REMAINS THE PROPERTY OF THE COMPANY.

GENERAL ARRANGEMENT

P024AVR3SA-LTS-U P030AVR3SA-LTS-U
 P035AVR3SA-LTS-U P040AVR3SA-LTS-U
 P045AVR3SA-LTS-U

www.apacair.com.au

ABN: 74 005 138 769

REVISION	REVISED NAMEPLATE WITH APAC DETAILS				
 ATLANTIC DR. KEYSBOROUGH VIC 3173 1300 555 545 by Rinnai	DRAWN	MT	DRAWING No.		A4
	DATE	11.03.14	GAD0015		
	SCALE	N.T.S.			
	CHECKED	HA	APP'D.	CM	REV.

NOTES:

1. GENERAL ARRANGEMENT OF A VERTICAL AIR COOLED PACKED UNIT
2. POWER AND FIELD CABLE ENTRIES, 1 x 32 ϕ AND 2 x 25 ϕ (BOTH SIDES)
3. ELECTRICAL PANEL LOCATED BEHIND SERVICE ACCESS
4. CONDENSATE OUTLET 25 ϕ
5. UNIT BASE 4 x 16 ϕ FIXING POINTS
6. UNIT HAS 4 x 25.4 ϕ LIFTING POINTS
7. UNIT CONFIGURATION IS TOP RIGHT SUPPLY, REAR RIGHT RETURN.

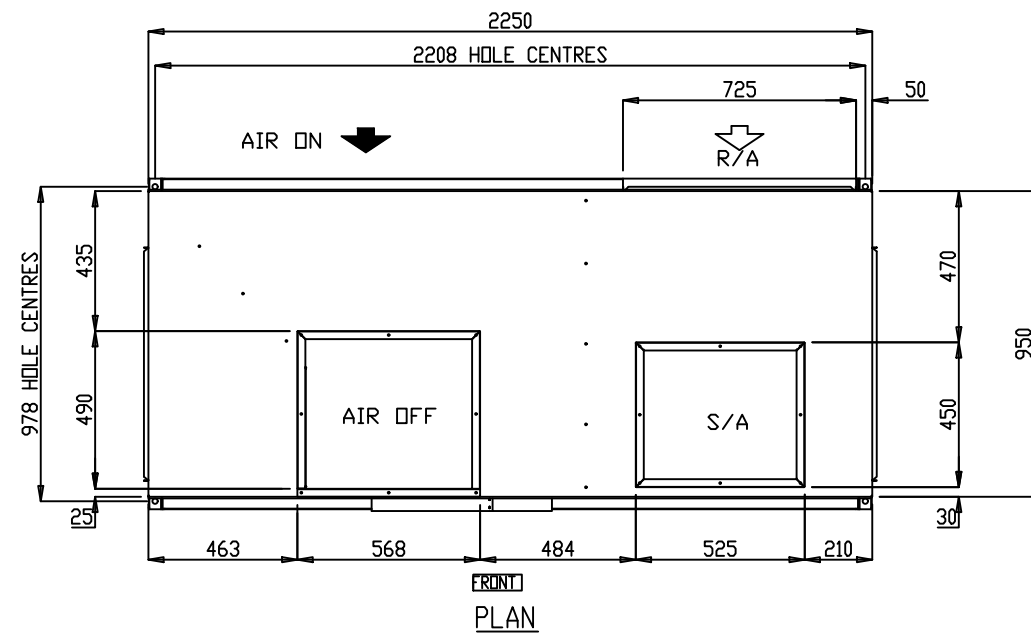

DIMENSION	P024-035	P040-045
A	1145	1600
B	700	245

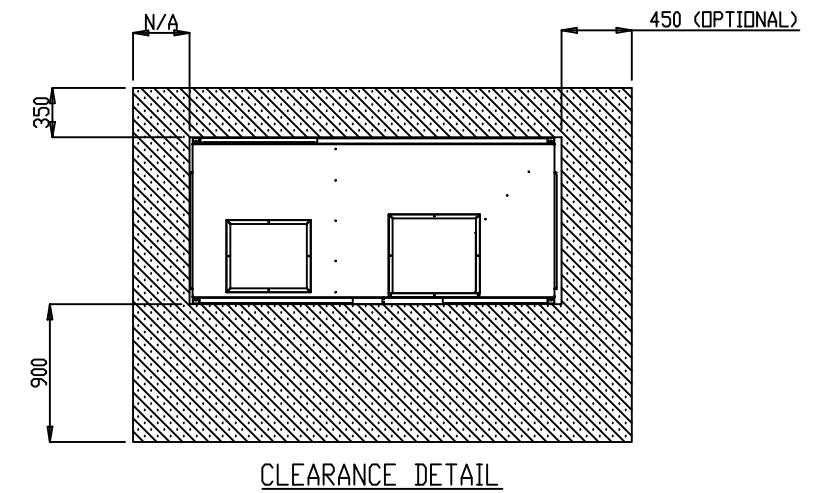
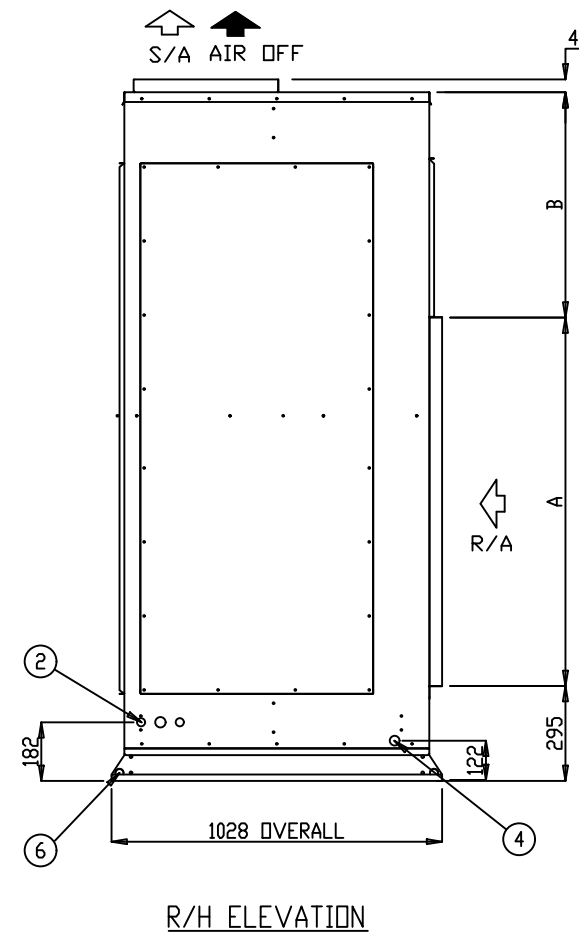
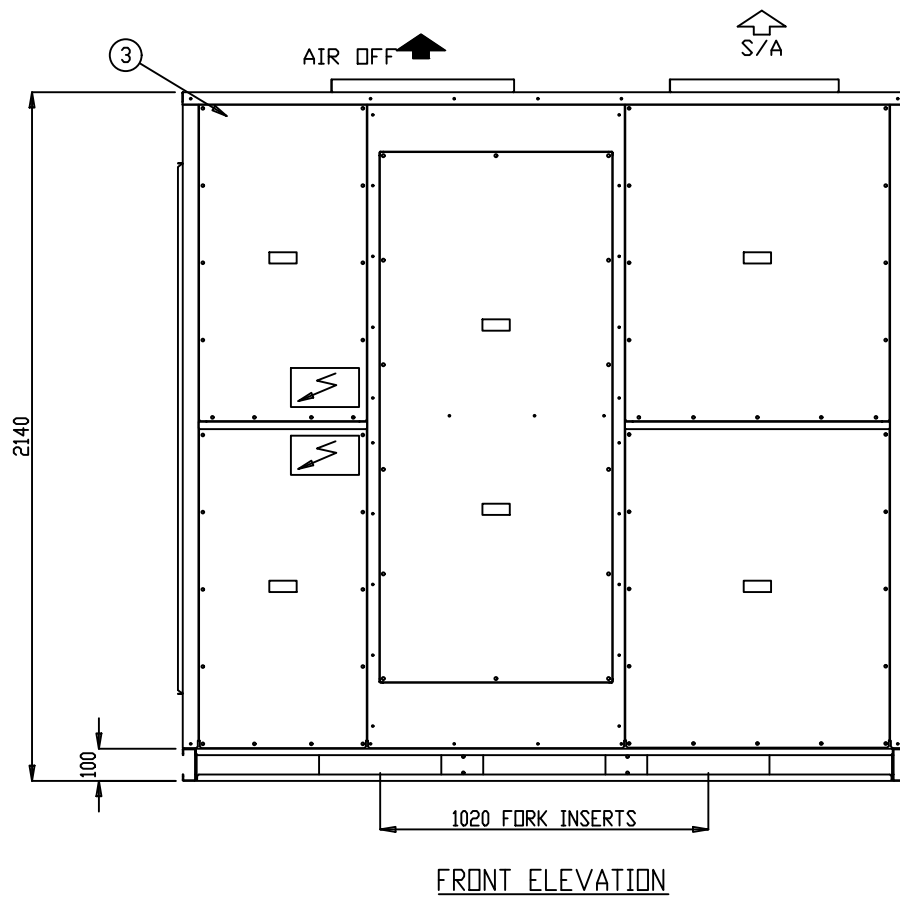

- ALL DIMENSIONS IN mm.
- GENERAL TOLERANCE ± 1 mm.
- DO NOT SCALE DRAWING.
- MASTER DRAWINGS ARE HELD ELECTRONICALLY. ANY COPY IS DEEMED UNCONTROLLED AND THEREFORE NOT NECESSARILY THE LATEST REVISION.
- ALL INFORMATION REMAINS THE PROPERTY OF THE COMPANY.

GENERAL ARRANGEMENT

P024AVR3SA-RTR-U P030AVR3SA-RTR-U
 P035AVR3SA-RTR-U P040AVR3SA-RTR-U
 P045AVR3SA-RTR-U

www.apacair.com.au

ABN: 74 005 138 769

REVISION	REVISED NAMEPLATE WITH APAC DETAILS				
 ATLANTIC DR. KEYSBOROUGH VIC 3173 1300 555 545	DRAWN	MT	DRAWING No.	A4	
	DATE	07.03.14	GAD0045		
	SCALE	N.T.S.			
	CHECKED	HA	APP'D.	CM	REV.

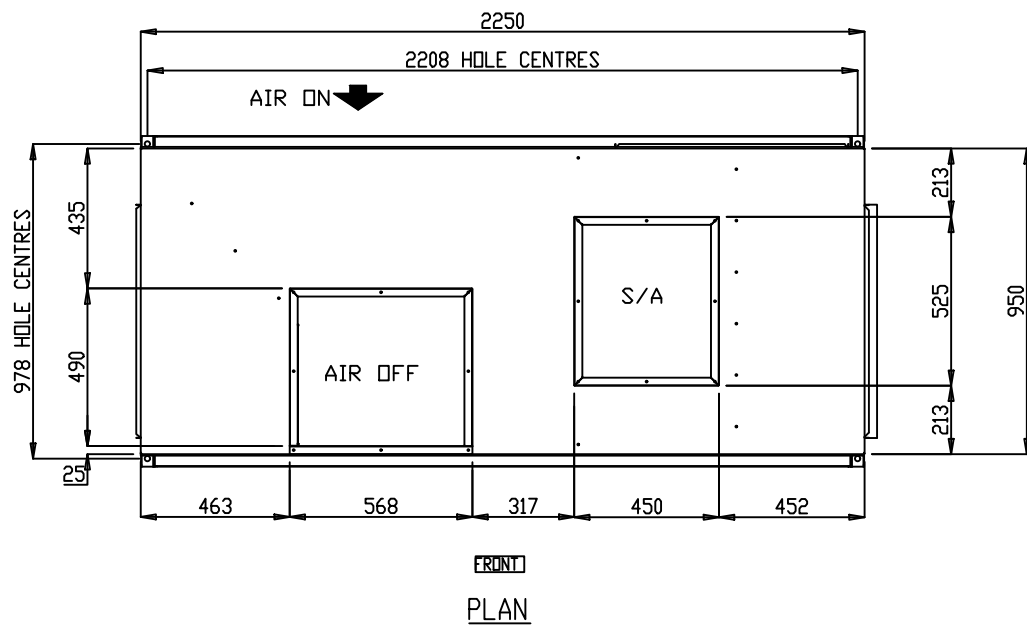

DIMENSION	P024-035	P040-045
A	1145	1600
B	700	245

- NOTES:**
1. GENERAL ARRANGEMENT OF A VERTICAL AIR COOLED PACKED UNIT
 2. POWER AND FIELD CABLE ENTRIES, 1 x 32 ϕ AND 2 x 25 ϕ (BOTH SIDES)
 3. ELECTRICAL PANEL LOCATED BEHIND SERVICE ACCESS
 4. CONDENSATE OUTLET 25 ϕ
 5. UNIT BASE 4 x 16 ϕ FIXING POINTS
 6. UNIT HAS 4 x 25.4 ϕ LIFTING POINTS
 7. UNIT CONFIGURATION IS TOP RIGHT SUPPLY, SIDE RIGHT RETURN.

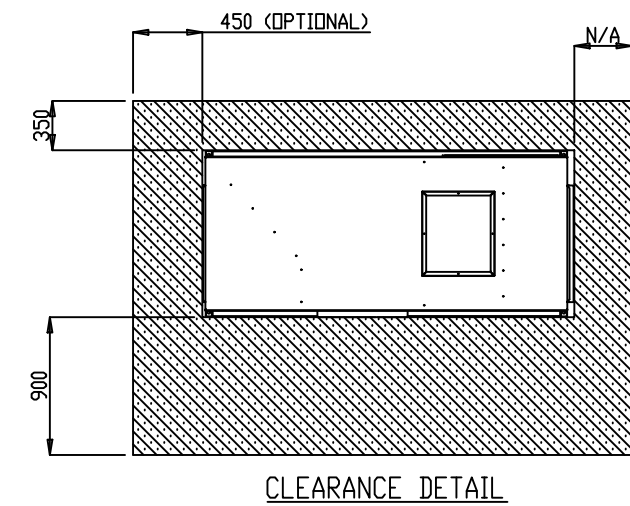
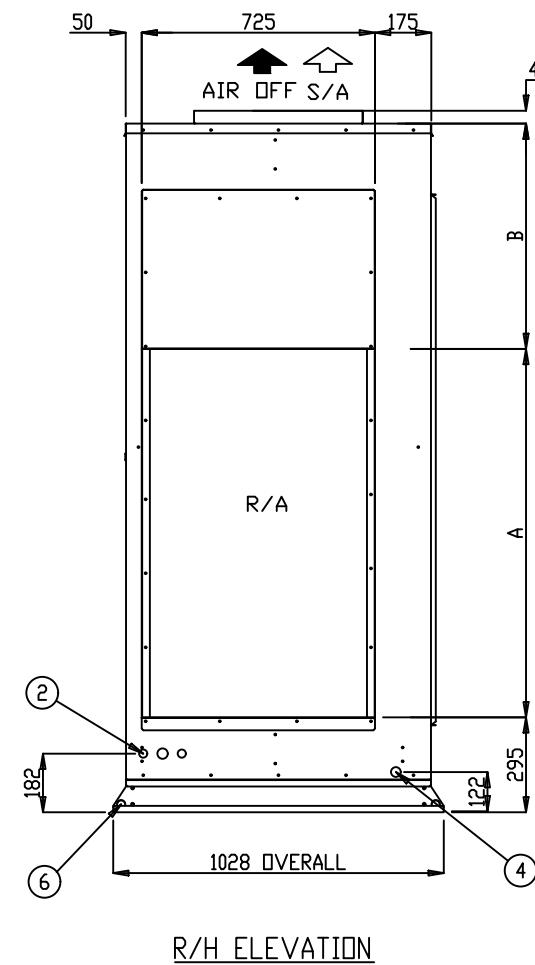
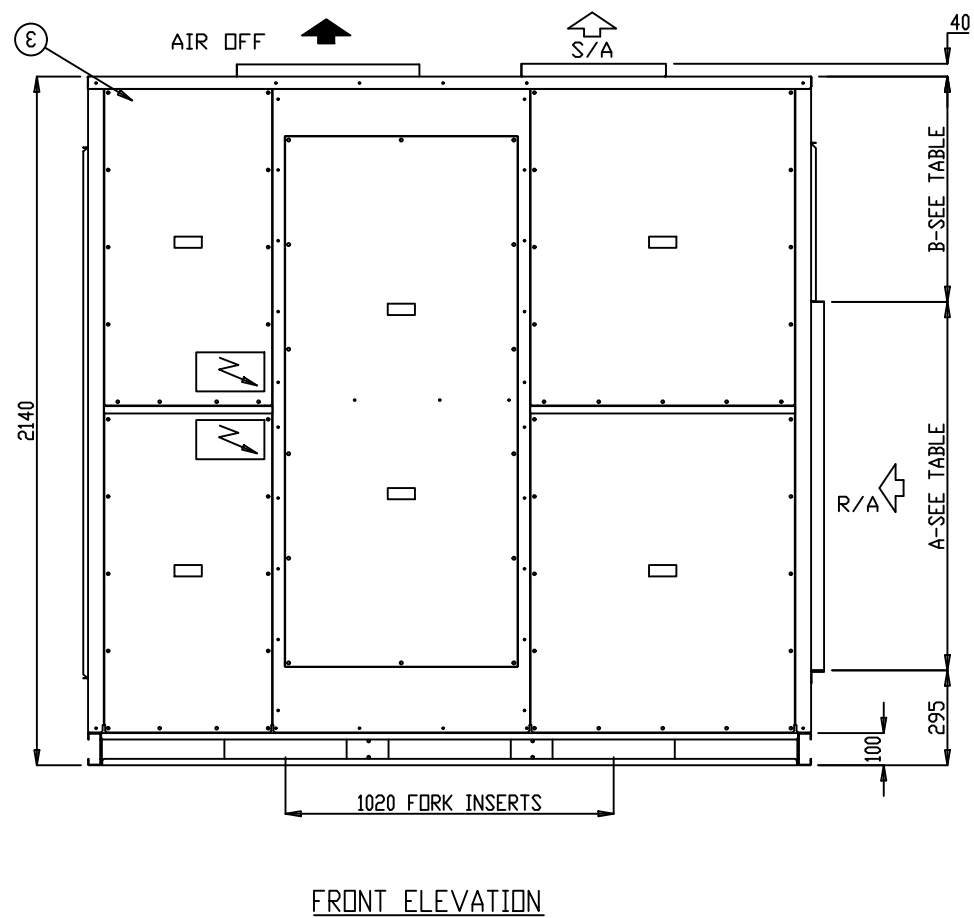

- ALL DIMENSIONS IN mm.
- GENERAL TOLERANCE ± 1 mm.
- DO NOT SCALE DRAWING.
- MASTER DRAWINGS ARE HELD ELECTRONICALLY. ANY COPY IS DEEMED UNCONTROLLED AND THEREFORE NOT NECESSARILY THE LATEST REVISION.
- ALL INFORMATION REMAINS THE PROPERTY OF THE COMPANY.

GENERAL ARRANGEMENT

P024AVR3SA-RTS-U P030AVR3SA-RTS-U
P035AVR3SA-RTS-U P040AVR3SA-RTS-U
P045AVR3SA-RTS-U

www.apacair.com.au

ABN: 74 005 138 769

REVISION		REVISED NAMEPLATE WITH APAC DETAILS			
 ATLANTIC DR. KEYSBOROUGH VIC 3173 1300 555 545 by Rinnai		DRAWN	MT	DRAWING No.	A4
		DATE	11.03.14	GAD0046	
		SCALE	N.T.S.		
		CHECKED	HA	APP'D.	CM

TECHNICAL DATA SHEET

MODEL NUMBER	P024AVR3SA-	P030AVR3SA-	P035AVR3SA-	P040AVR3SA-	P045AVR3SA-		
MEPS REGISTRATION NUMBER	AAC3283	AAC3285	AAC3278	AAC3284	AAC3279		
CONDENSER SECTION	CAPACITY						
	Cooling	kW TOTAL*	25.14	31.00	34.13	39.78	45.27
		kW SENSIBLE*	18.86	25.25	27.06	31.25	35.00
		EER (kW / ikW)*	3.59	3.60	3.44	3.40	3.27
	Heating	kW TOTAL	23.80	30.20	34.25	40.09	43.53
		COP	3.66	3.60	3.85	3.61	3.71
	CAPACITY STEPS (%)		50/100	50/100	50/100	50/100	50/100
	COMPRESSOR						
	TYPE	SCROLL	SCROLL	SCROLL	SCROLL	SCROLL	
	STARTER TYPE	D.O.L (Opt Soft/Start)	D.O.L (Opt Soft/Start)	D.O.L (Opt Soft/Start)	D.O.L (Opt Soft/Start)	D.O.L (Opt Soft/Start)	
	PHASE	3Ø	3Ø	3Ø	3Ø	3Ø	
	No. OFF	2	2	2	2	2	
	PROTECTION DEVICES	HP SWITCH, LP SWITCH, MOTOR OVERLOAD'S					
	ALL COMPRESSORS HAVE	CRANKCASE HEATER					
	FAN						
	TYPE	AXIAL	AXIAL	AXIAL	AXIAL	AXIAL	
	ikW (MAX INPUT)	0.39	0.39	0.39	0.60	0.60	
	PHASE	1Ø	1Ø	1Ø	1Ø	1Ø	
	No. OFF	2	2	2	2	2	
	FAN SPEED CONTROL	VARIABLE SPEED	VARIABLE SPEED	VARIABLE SPEED	VARIABLE SPEED	VARIABLE SPEED	
	HEAT EXCHANGER						
	TYPE	PLATE FIN COIL	PLATE FIN COIL	PLATE FIN COIL	PLATE FIN COIL	PLATE FIN COIL	
	NOM. AIRFLOW l/s	-	-	-	-	-	
	REFRIGERANT SYSTEM						
TYPE	R410A						
CHARGE PER CIRCUIT (KG)	3.95	5.3	5.7	7.3	6.8		
No. OF CIRCUITS	2	2	2	2	2		
REFRIGERANT CONTROL	TXV						
ALL SYSTEMS INCLUDE	DRIERS & SIGHT GLASSES						
EVAPORATOR SECTION	FAN						
	TYPE	CENTRIFUGAL	CENTRIFUGAL	CENTRIFUGAL	CENTRIFUGAL	CENTRIFUGAL	
	ikW (MAX INPUT)	2.73	2.73	2.73	1.7	1.7	
	PHASE	3Ø	3Ø	3Ø	3Ø	3Ø	
	No. OFF	1	1	1	2	2	
	FAN SPEED CONTROL	VARIABLE SPEED	VARIABLE SPEED	VARIABLE SPEED	VARIABLE SPEED	VARIABLE SPEED	
	HEAT EXCHANGER						
	TYPE	PLATE FIN COIL	PLATE FIN COIL	PLATE FIN COIL	PLATE FIN COIL	PLATE FIN COIL	
NOM. AIRFLOW l/s	1250	1670	1750	1985	2235		
EXT STATIC pa	100						
COMBINED SECTIONS	ELECTRICAL						
	MAINS POWER	415v / 3Ø / 50hz	415v / 3Ø / 50hz	415v / 3Ø / 50hz	415v / 3Ø / 50hz	415v / 3Ø / 50hz	
	H.P. CUT OUT / IN kPa	4500 / 3450	4500 / 3450	4500 / 3450	4500 / 3450	4500 / 3450	
	L.P. CUT OUT / IN kPa	175 / 345	175 / 345	175 / 345	175 / 345	175 / 345	
	NOM. R.L.A. (TOTAL SYSTEM)	13.9	16.1	19.8	21.2	23.5	
	MAX. F.L.A. (TOTAL SYSTEM)	23.8	28.4	31.4	40.5	40.5	
	GENERAL						
	CABINET	GALVANISED SHEET STEEL					
	INSULATION	ALUMINIUM FOIL FACED POLYETHYLENE ACOUSTIC INSULATION					
	EXTERNAL FINISH	POLYESTER POWDER COAT - COLOUR LIGHT GREY AS STANDARD - OPTIONS AVAILABLE					
	DIMENSIONS						
	H X W X D (mm)	2140 X 2250 X 950					
	WEIGHT						
	OPERATING KG	570	580	590	610	620	
SHIPPING KG	575	585	595	615	625		
NOISE LEVELS (Based on condenser fan's sound data)							
Sound Power db(A)	66.5	66.5	66.5	68.7	68.7		

Note: Tested in accordance with AS/NZS3823.1.2

*Performance excludes ikW of evaporator fan motor.

R.L.A - Run Load Amps are based on current drawn at nominal conditions

F.L.A - Full Load Amps are based on the overload settings [Max Current] of all Compressor and Fan Motor(s).

Date	Document #	Approved By	Revision
31/5/18	TDS0015	CM	F

NOTE: Due to continuous improvement Rinnai Australia Pty Ltd reserve the right to change details without notice.



TECHNICAL DATA SHEET						
FACTORY OPTION U - DUCTABLE AIR OFF EXHAUST						
MODEL NUMBER	P024AVR3SA-	P030AVR3SA-	P035AVR3SA-	P040AVR3SA-	P045AVR3SA-	
CONDENSER SECTION	FAN					
	TYPE	EC PLUG FAN	EC PLUG FAN	EC PLUG FAN	EC PLUG FAN	EC PLUG FAN
	ikW (MAX INPUT)	2.73	2.73	2.73	2.73	2.73
	PHASE	3∅	3∅	3∅	3∅	3∅
	No. OFF	2	2	2	2	2
	FAN SPEED CONTROL	VARIABLE SPEED	VARIABLE SPEED	VARIABLE SPEED	VARIABLE SPEED	VARIABLE SPEED
	External Static Pressure					
	Pa	0 -100				
	Air Flow Rate					
	l/s	3620	3620	3620	5000	5000
	ELECTRICAL					
	NOM. R.L.A. (TOTAL SYSTEM)	12.5	14.8	18.5	20.8	23.1
	MAX. F.L.A. (TOTAL SYSTEM)	23.4	28.0	31.0	38.4	38.4
	TOTAL P.I (kW)	7.6	9.2	10.5	13.4	15.5
	NOISE LEVELS [Based on condenser fan's sound data]					
	Sound Power db(A)	87.5	87.5	87.5	95.4	95.4

Note: The technical data sheet is for high static outdoor fan (ductable) option. This should be read in conjunction with TDS0015. The Electrical is assumed for 75Pa of External Static Pressure, this may change depending on ductwork.

Date	Document #	Approved By	Revision
1/6/18	TDS0040	CM	C

NOTE: Due to continuous improvement Rinnai Australia Pty Ltd reserve the right to change details without notice.

FAN PERFORMANCE CURVE

P045AVR3SA-

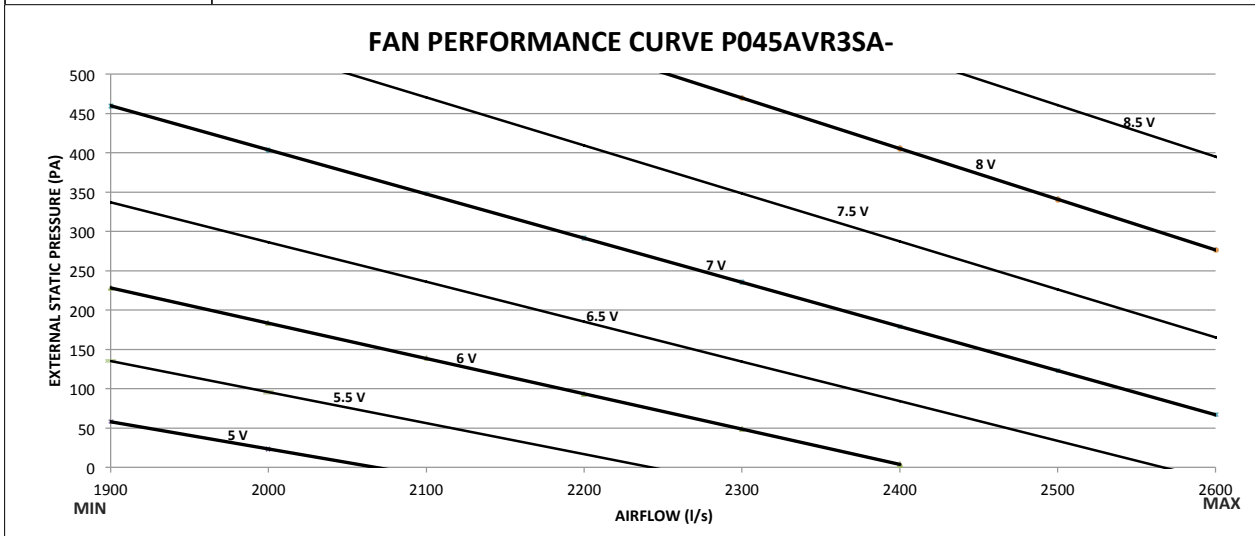

Note:

1. 5V, 5.5 V, 6V, 6.5V, 7V, 7.5V, 8V and 8.5V represents potentiometer voltage. Potentiometer can be adjusted to achieve desired flowrates.
2. Potentiometer voltage can be varied infinitely between 0 to 10V.

Date	Document #	Approved By	Revision
29.05.18	FPC0057	CM	B

NOTE: Due to continuous improvement Rinnai Australia Pty Ltd reserve the right to change details without notice.



SOUND DATA

MODEL NUMBER

P045AVR3SA-

Outdoor Fan

Sound Power Level dB(A)	Octave band Centre Frequency (Hz), dB						
	125	250	500	1k	2k	4k	8k
68.7	75.6	63.7	64.1	63.2	61.4	58.2	55.3

Indoor Fan

Sound Power Level dB(A)	Air Flow (l/s)	Octave band Centre Frequency (Hz), dB						
		125	250	500	1k	2k	4k	8k
85.6	2236	67	74.3	77.5	81.1	78.4	77.8	76.5

Date	Document #	Approved By	Revision
02.06.18	SD0048	CM	B

NOTE: Due to continuous improvement Rinnai Australia Pty Ltd reserve the right to change details

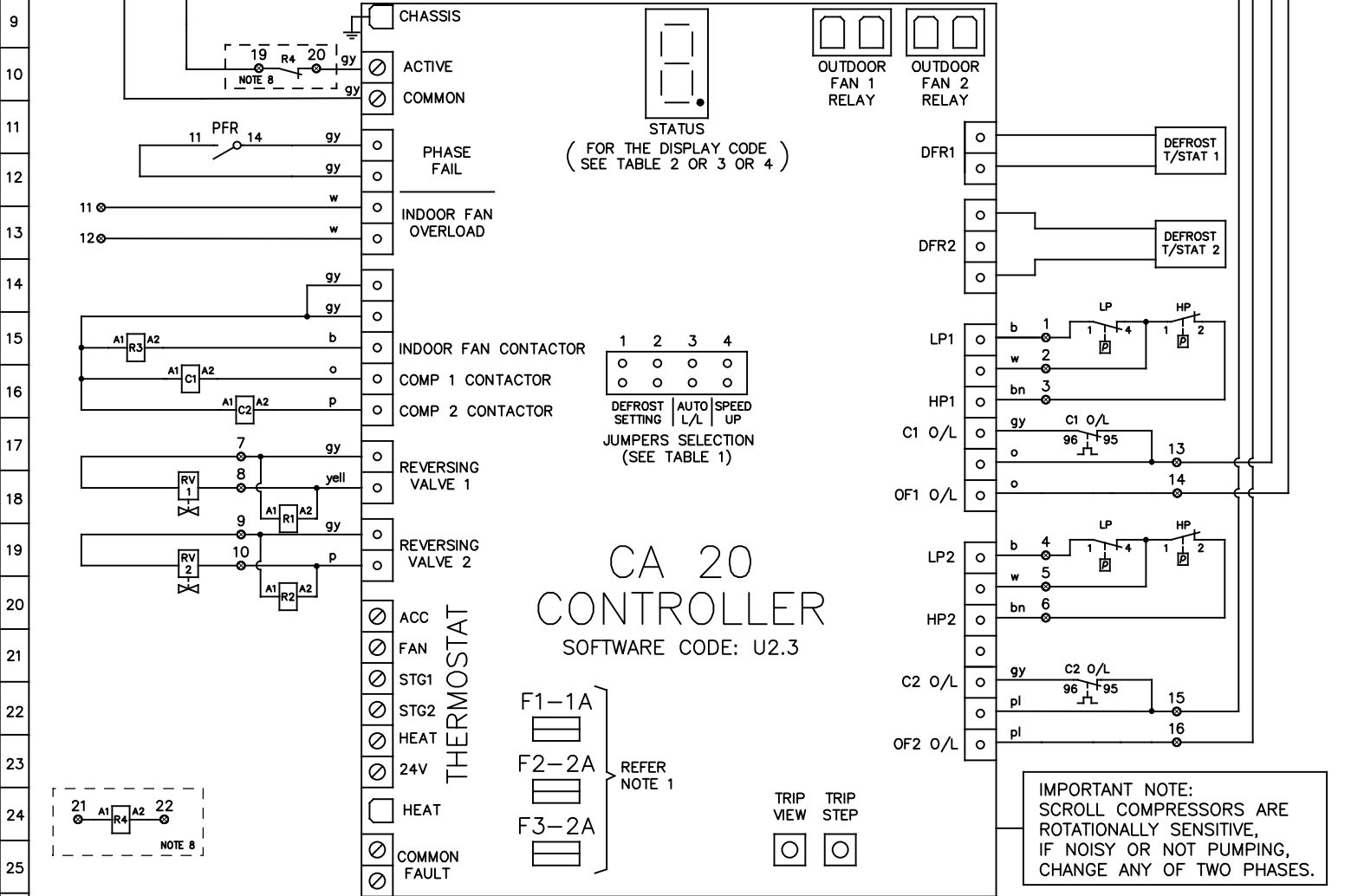
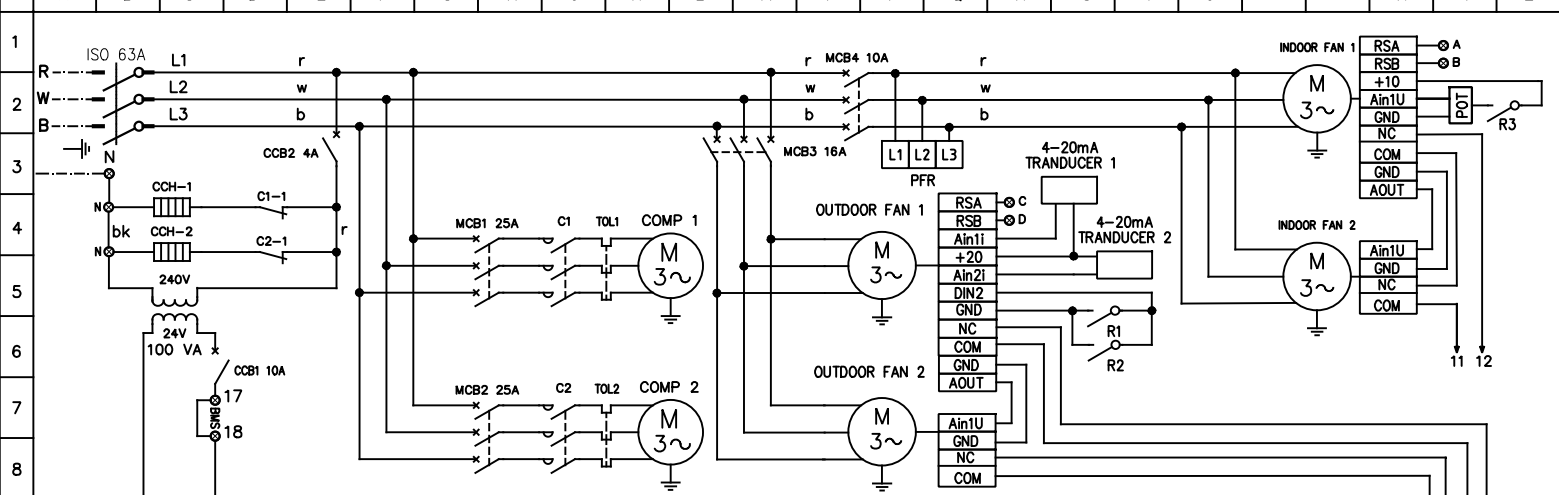

CA 20 CONTROLLER

SOFTWARE CODE: U2.3

IMPORTANT NOTE:
SCROLL COMPRESSORS ARE ROTATIONALLY SENSITIVE, IF NOISY OR NOT PUMPING, CHANGE ANY OF TWO PHASES.

WARNING! THE SOFTWARE OF THE CA20 CONTROLLER IS NOT DESIGNED TO FUNCTION AS A PRIMARY PERSONAL SAFETY DEVICE, AS CONNECTED EQUIPMENT CAN START AUTOMATICALLY WITHOUT WARNING. ALSO, OPENING THERMOSTAT CONTACTS MAY NOT CAUSE THE EQUIPMENT TO STOP. OUTDOOR FAN MOTORS HAVE INTERNAL OVERLOADS AND MAY RESTART AUTOMATICALLY.

- NOTES:
- TIME DELAY GLASS FUSES ON THE PCB CONTROLLER ARE THE FOLLOWING:
 - F1 PROTECTS THE THERMOSTAT CIRCUIT.
 - F2 PROTECTS THE REVERSING VALVE CIRCUITS AND THE "HEAT" OUTPUT. THIS FUSE F2 ALSO SUPPLIES FUSE F1.
 - F3 PROTECTS BOTH COMPRESSOR CONTACTOR CIRCUITS AND THE INDOOR FAN CONTACTOR CIRCUIT.
 - HP CUT OUT & LP CUT OUT - AUTO RESET.
 - THERMAL OVERLOAD RELAYS - AUTO RESET, UNLESS OTHERWISE STATED.
 - DO NOT CONNECT ANY ADDITIONAL EQUIPMENT TO THE CONTROL TRANSFORMER OTHER THAN THE EQUIPMENT SHOWN ON THE ELECTRICAL DRAWING.
 - ALL FIELD WIRING IS THE RESPONSIBILITY OF THE INSTALLING CONTRACTOR AND MUST COMPLY WITH AS/NZS 3000 AND LOCAL RULES.
 - SOFTWARE CODE MUST BE CHECKED AFTER REPLACEMENT OF THE CA-20 CONTROLLER BY CHECKING THE DISPLAY CODE ON THE 7 SEGMENT DISPLAY AFTER THE CONTROLLER IS ACTIVATED.
 - OPTIONAL FIRE ALARM RELAY

JUMPERS SELECTION	DEFROST INTERVAL TIME SETTING	JUMPERS SELECTION	AUTO LEAD/LAG	JUMPERS SELECTION	SPEED UP
	15 min		OFF		OFF
	FACTORY SETTING 30 min		ON		ON
	45 min		ON		ON

UNIT MUST BE SWITCHED OFF BEFORE CHANGING THE JUMPER SELECTION

LEGEND		LEGEND		COLOUR CODE	COMPRESSOR (EACH)		MODEL:	PO45AVR3SA	
	TERMINAL SWITCHBOARD	TOL	THERMAL OVERLOAD RELAY	r	RED	KW	5.52	OPTIONS	
	TERMINAL	R	RELAY	w	WHITE	RATED CURRENT	15.00	DESCRIPTION	
	FIELD WIRING	C	CONTACTOR	b	BLACK	O/L SETTING	16.50	DUCTABLE AIR OFF	
	CONTROL PARAMETER	COMP	COMPRESSOR	bk	BROWN	FANS (EACH)	KW	FLA	
	MAINS/CONTROL WIRING	ISO	ISOLATOR SWITCH	bn	ORANGE	OUTDOOR	2.73	4.20	
	CCH	MCB	MINIATURE CIRCUIT BREAKER	o	PINK	INDOOR	1.70	2.60	
	PFR	CCB	CONTROL CIRCUIT BREAKER	p	PURPLE				
	RV	O/L	OVERLOAD	pl	GREY				
	HP	POT	POTENTIOMETER	gy	YELLOW				
	LP			yell					



DATE	24/06/2018		
DWN	S.P	APPD	ENG
REV	A	GRID	B147
DWG No.	EWS02281		