



VPU HANDING CONFIRMATION

DO NUMBER (INTERNAL USE)	WO NUMBER (INTERNAL USE)
-----------------------------	-----------------------------

VERTICAL PACKAGED UNITS (VPU)

MODELS	P024-045AVR3SA-
GENERAL	This document details the airside configurations available on 024-045 VPU models.
SOURCING	Standard configuration is LTR. Optional airside configurations to be specified at time of order.
HOW TO USE THIS DOCUMENT	<ol style="list-style-type: none"> 1. Choose if the supply air fan position is required on the left or right. 2. Circle the required supply air outlet. 3. Circle the required return air inlet. 4. Complete the information at the bottom of this document and return to your APAC representative.

LTR – TOP LEFT SUPPLY / REAR LEFT RETURN
(REPLACEMENT FOR FRIGIPOL & APAC S25, 30, 35, 45)

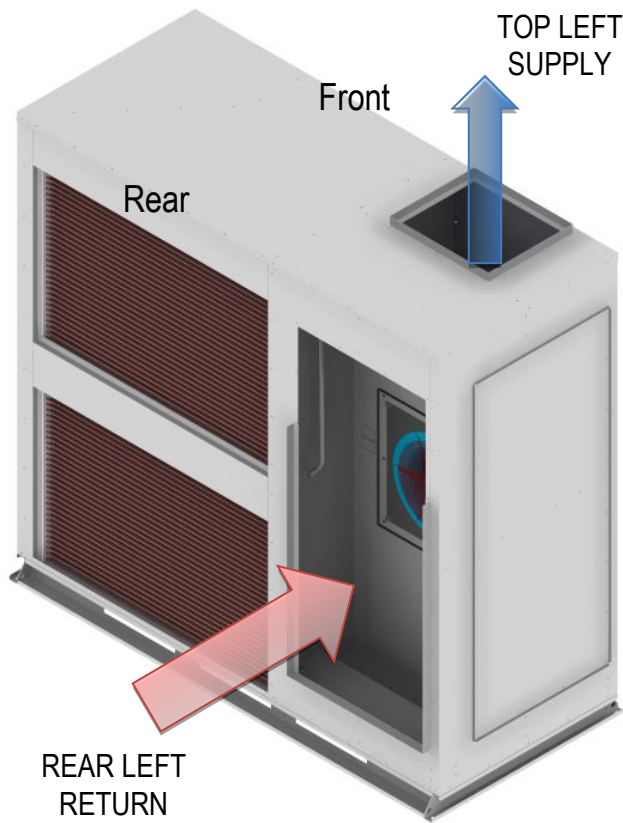

RTR – TOP RIGHT SUPPLY / REAR RIGHT RETURN
(REPLACEMENT FOR FRIGIPOL & APAC S25, 30, 35, 45)

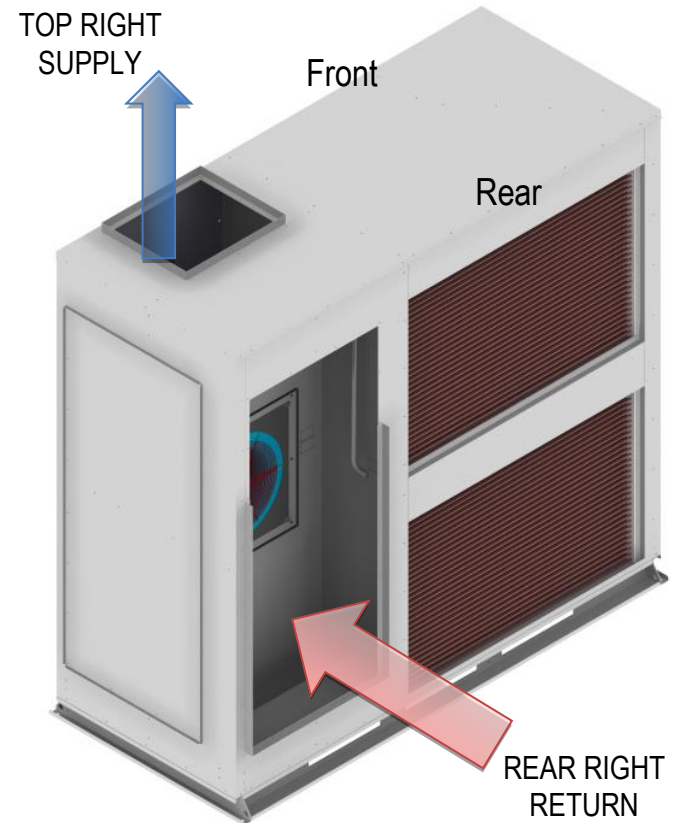

LTS – TOP LEFT SUPPLY / SIDE LEFT RETURN
(REPLACEMENT FOR FRIGIPOL & APAC S25, 30, 35, 45)

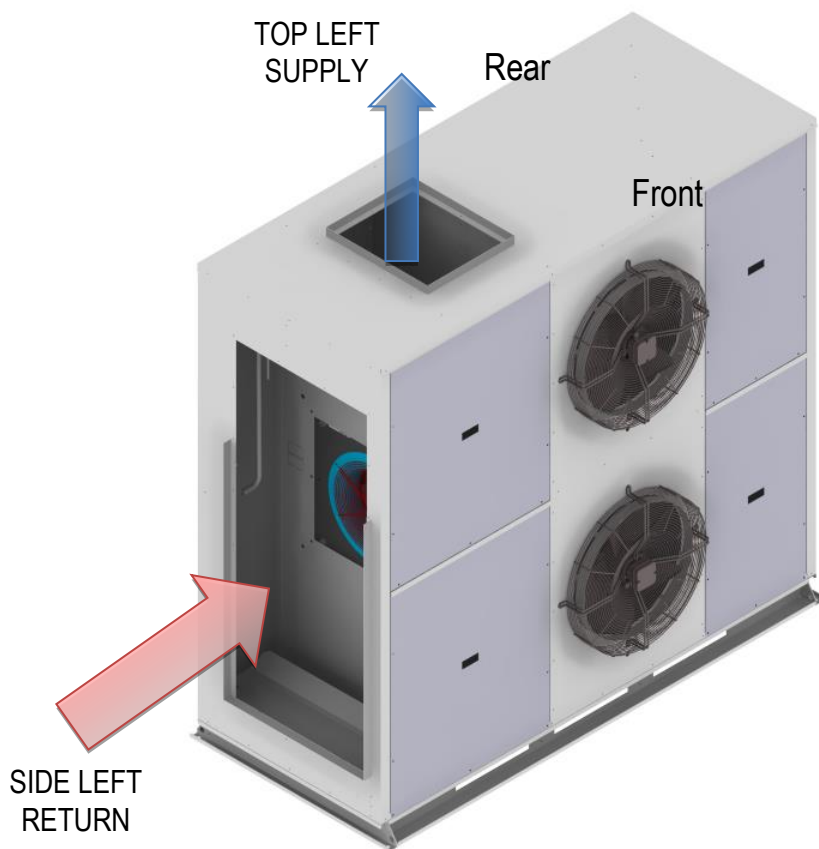

RTS – TOP RIGHT SUPPLY / SIDE RIGHT RETURN
(REPLACEMENT FOR FRIGIPOL & APAC S25, 30, 35, 45)

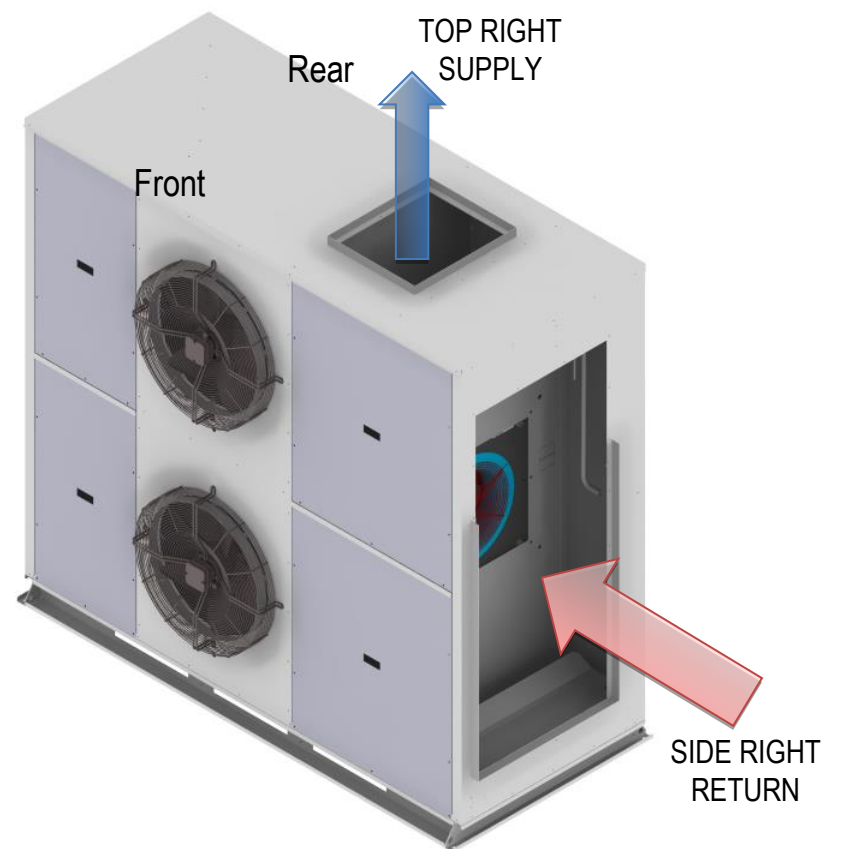

CUSTOMER TO COMPLETE AND RETURN

CUSTOMER	PROJECT	UNIT REF	NAME / SIGN	DATE

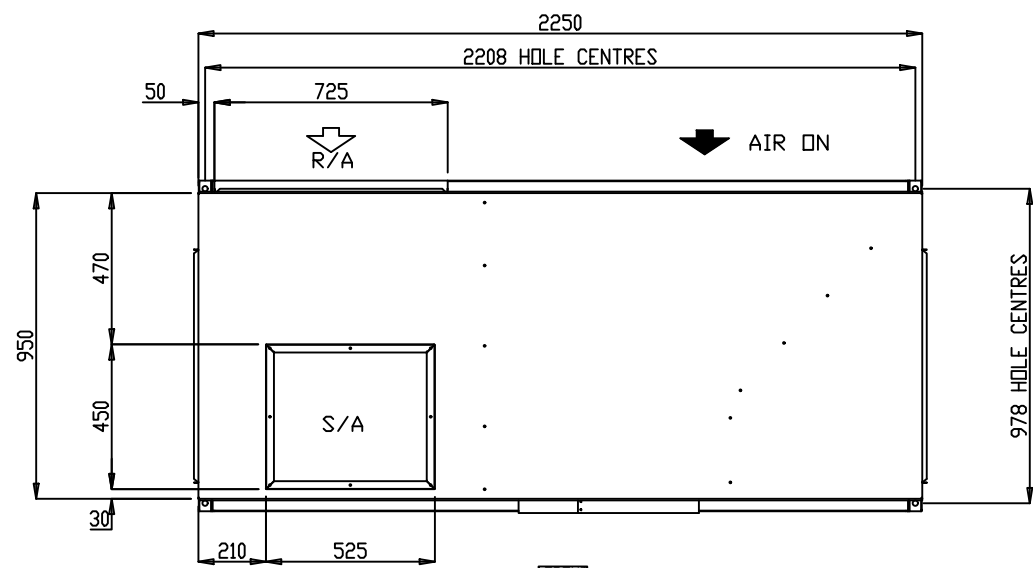

DIMENSION	P024-035	P040-045
A	1145	1600
B	700	245

- NOTES:**
1. GENERAL ARRANGEMENT OF A VERTICAL AIR COOLED PACKED UNIT
 2. POWER AND FIELD CABLE ENTRIES, 1 x 32 ϕ AND 2 x 25 ϕ (BOTH SIDES)
 3. ELECTRICAL PANEL LOCATED BEHIND SERVICE ACCESS
 4. CONDENSATE OUTLET 25 ϕ
 5. UNIT BASE 4 x 16 ϕ FIXING POINTS
 6. UNIT HAS 4 x 25.4 ϕ LIFTING POINTS
 7. UNIT CONFIGURATION IS TOP LEFT SUPPLY, REAR LEFT RETURN, OTHER CONFIGURATIONS AVAILABLE.

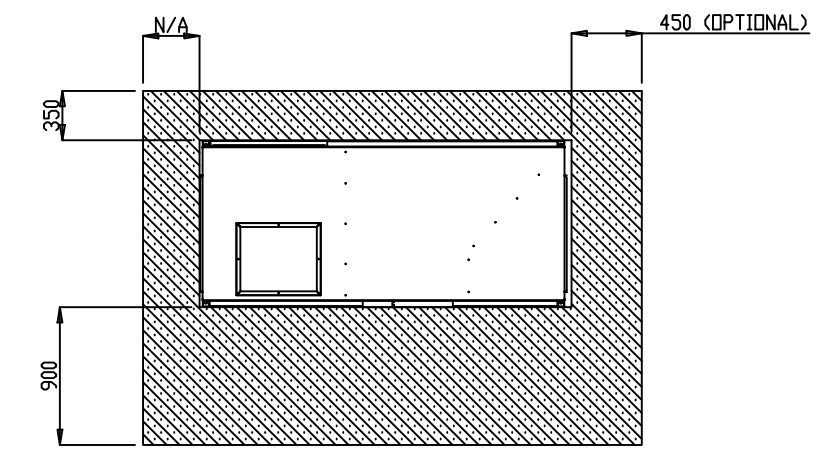
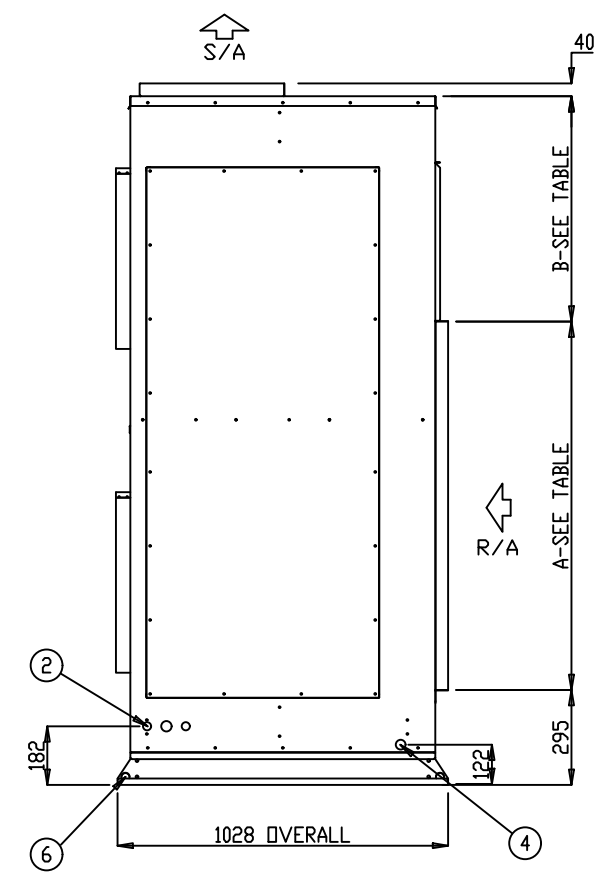
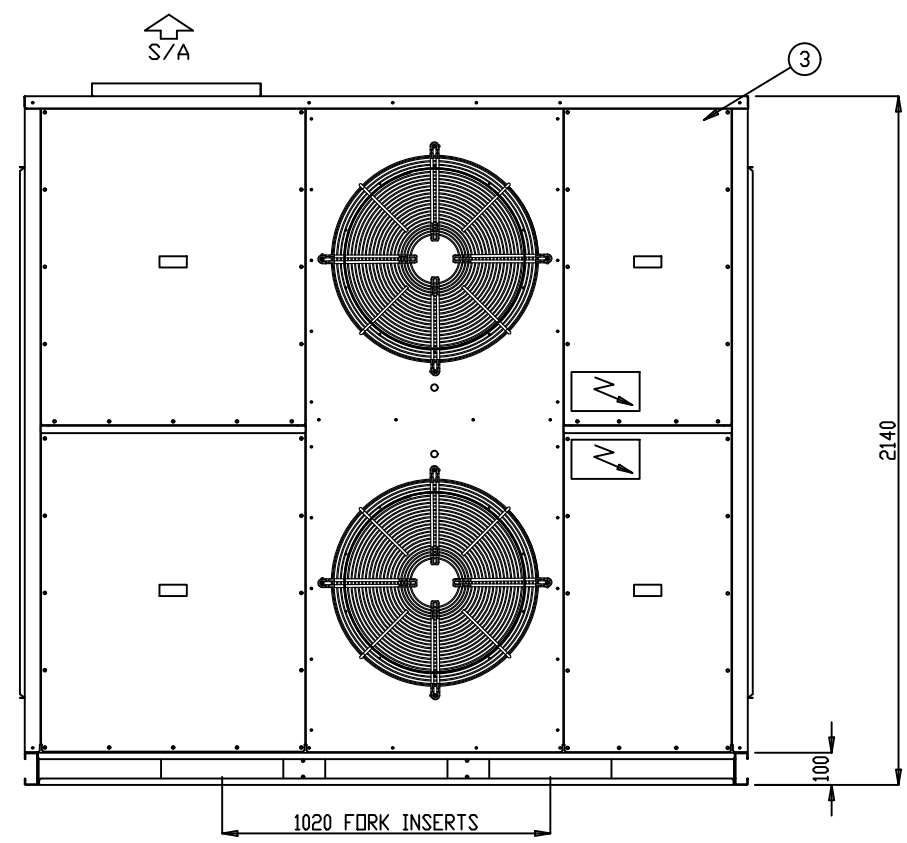

FRONT ELEVATION

R/H ELEVATION

CLEARANCE DETAIL

- ALL DIMENSIONS IN mm.
- GENERAL TOLERANCE ± 1 mm.
- DO NOT SCALE DRAWING.
- MASTER DRAWINGS ARE HELD ELECTRONICALLY. ANY COPY IS DEEMED UNCONTROLLED AND THEREFORE NOT NECESSARILY THE LATEST REVISION.
- ALL INFORMATION REMAINS THE PROPERTY OF THE COMPANY.

GENERAL ARRANGEMENT

P024AVR3SA-LTR P030AVR3SA-LTR P035AVR3SA-LTR
 P040AVR3SA-LTR P045AVR3SA-LTR

www.apacair.com.au ABN: 74 005 138 769

REVISION	REVISED NAMEPLATE WITH APAC DETAILS			
 ATLANTIC DR. KEYSBOROUGH VIC 3173 1300 555 545	DRAWN	MT	DRAWING No. A4	
	DATE	26.11.13	GAD0003	
	SCALE	N.T.S.		
	CHECKED	HA	APP'D.	CM

NOTES:

1. GENERAL ARRANGEMENT OF A VERTICAL AIR COOLED PACKED UNIT
2. POWER AND FIELD CABLE ENTRIES, 1 x 32 ϕ AND 2 x 25 ϕ (BOTH SIDES)
3. ELECTRICAL PANEL LOCATED BEHIND SERVICE ACCESS
4. CONDENSATE OUTLET 25 ϕ
5. UNIT BASE 4 x 16 ϕ FIXING POINTS
6. UNIT HAS 4 x 25.4 ϕ LIFTING POINTS
7. UNIT CONFIGURATION IS TOP RIGHT SUPPLY, REAR RIGHT RETURN, OTHER CONFIGURATIONS AVAILABLE.

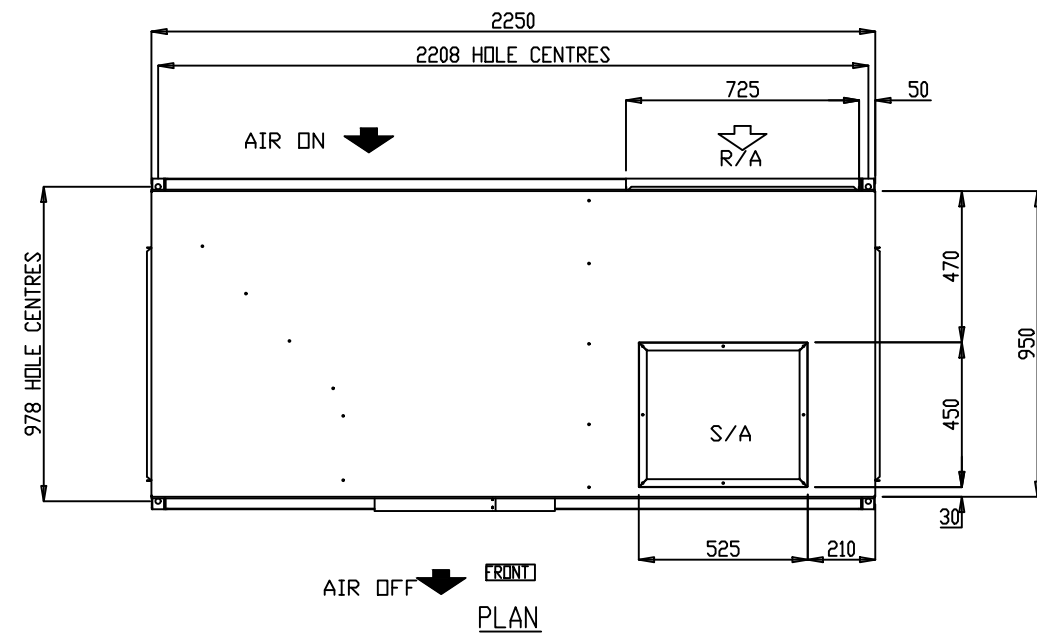

DIMENSION	APH024-035	APH040-045
A	1145	1600
B	700	245

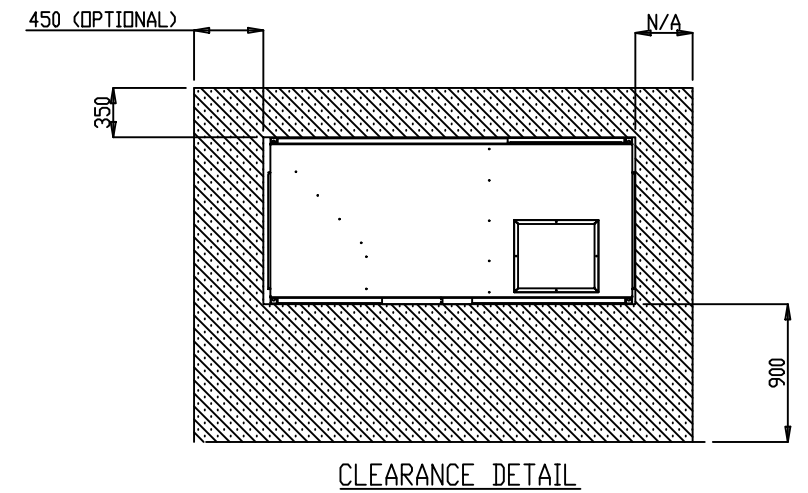
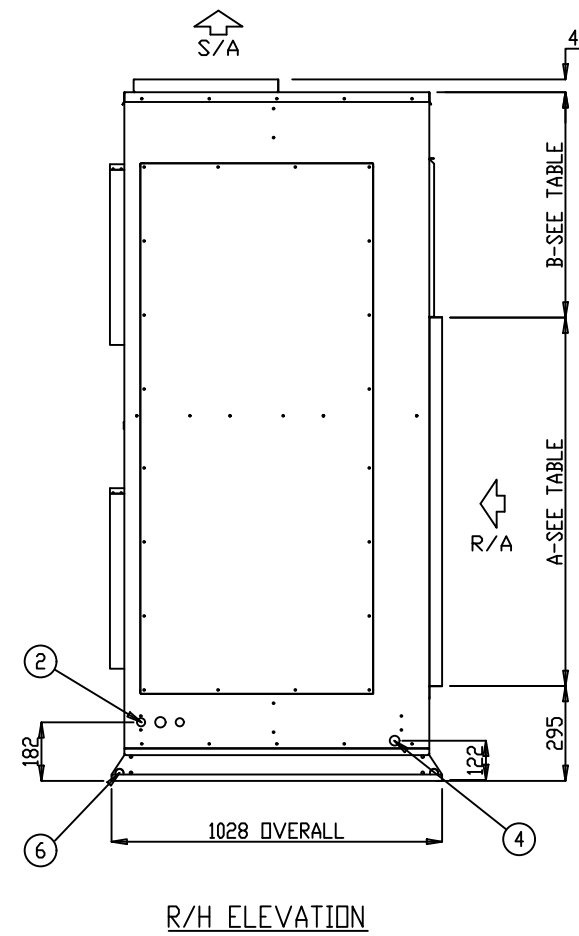
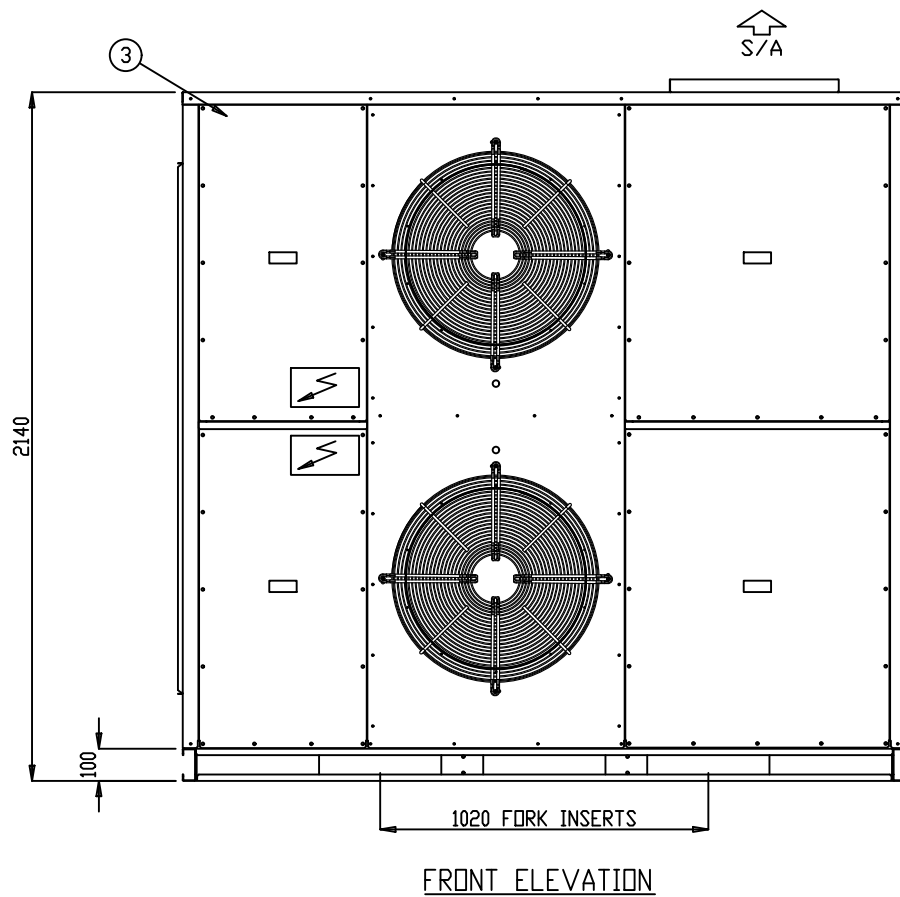

- ALL DIMENSIONS IN mm.
- GENERAL TOLERANCE ± 1 mm.
- DO NOT SCALE DRAWING.
- MASTER DRAWINGS ARE HELD ELECTRONICALLY. ANY COPY IS DEEMED UNCONTROLLED AND THEREFORE NOT NECESSARILY THE LATEST REVISION.
- ALL INFORMATION REMAINS THE PROPERTY OF THE COMPANY.

GENERAL ARRANGEMENT

P024AVR3SA-RTR P030AVR3SA-RTR P035AVR3SA-RTR
P040AVR3SA-RTR P045AVR3SA-RTR

www.apacair.com.au

ABN: 74 005 138 769

REVISION		REVISED NAMEPLATE WITH APAC DETAILS			
 ATLANTIC DR. KEYSBOROUGH VIC 3173 1300 555 545 by Rinnai		DRAWN	MT	DRAWING No.	A4
		DATE	26.11.13	GAD0004	
		SCALE	N.T.S.		
		CHECKED	HA	APP'D.	CM

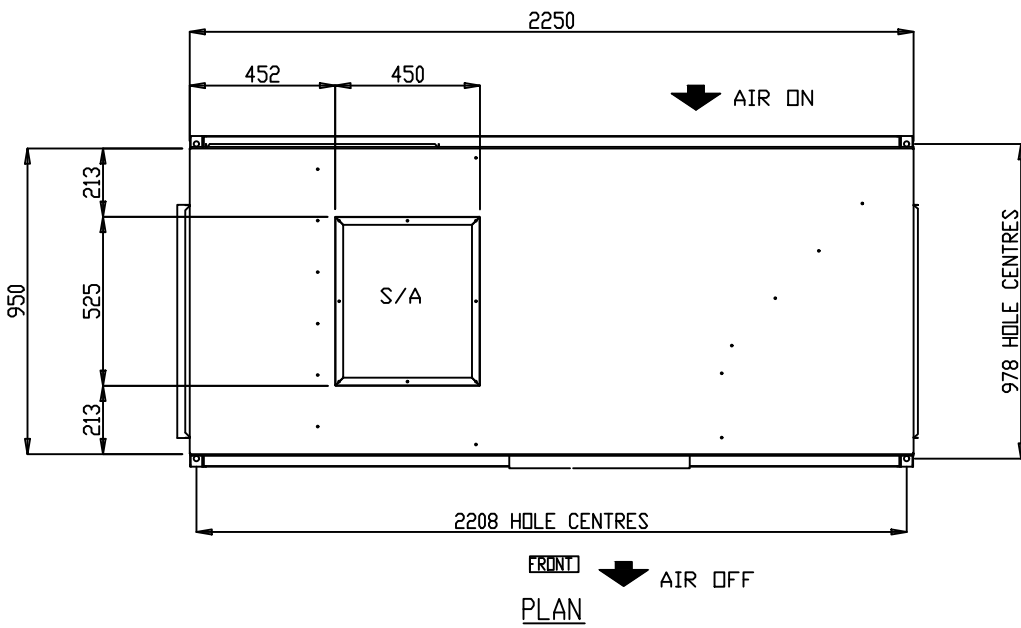

- NOTES:**
1. GENERAL ARRANGEMENT OF A VERTICAL AIR COOLED PACKED UNIT
 2. POWER AND FIELD CABLE ENTRIES, 1 x 32 ϕ AND 2 x 25 ϕ (BOTH SIDES)
 3. ELECTRICAL PANEL LOCATED BEHIND SERVICE ACCESS
 4. CONDENSATE OUTLET 25 ϕ
 5. UNIT BASE 4 x 16 ϕ FIXING POINTS
 6. UNIT HAS 4 x 25.4 ϕ LIFTING POINTS
 7. UNIT CONFIGURATION IS TOP LEFT SUPPLY, SIDE LEFT RETURN, OTHER CONFIGURATIONS AVAILABLE.

DIMENSION	APH024-035	APH040-045
A	1145	1600
B	700	245

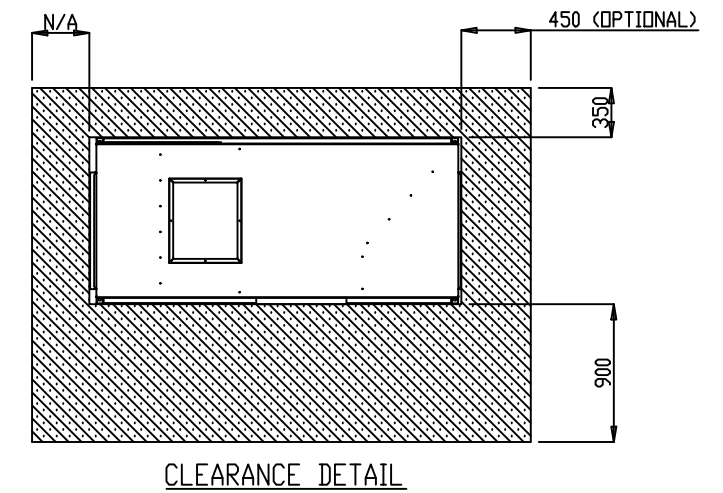
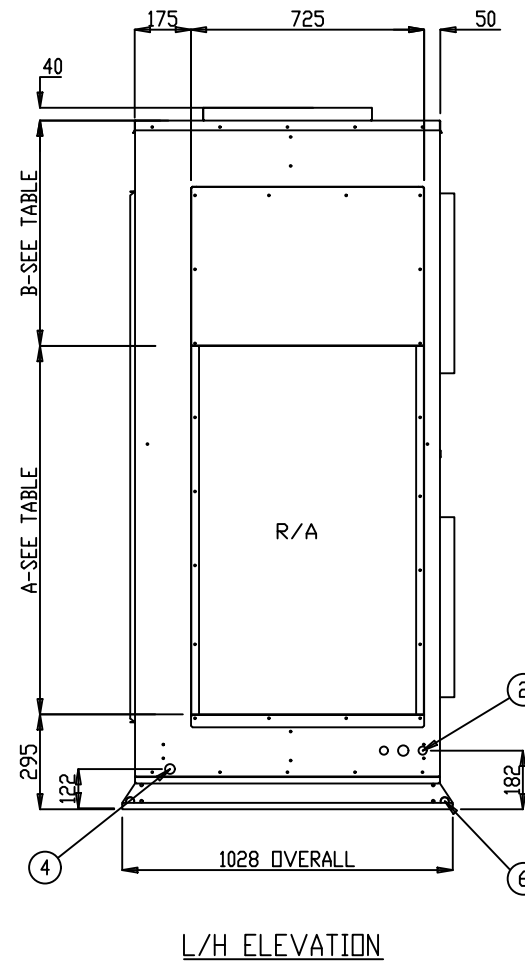
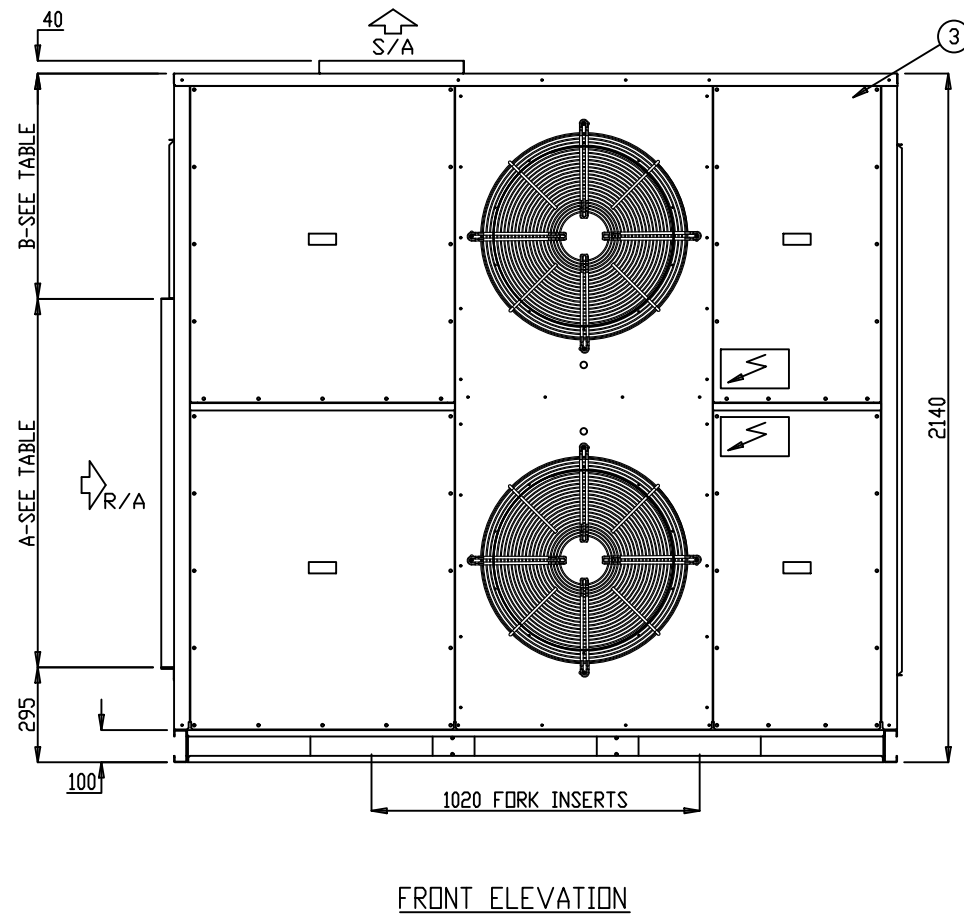

- ALL DIMENSIONS IN mm.
- GENERAL TOLERANCE ± 1 mm.
- DO NOT SCALE DRAWING.
- MASTER DRAWINGS ARE HELD ELECTRONICALLY. ANY COPY IS DEEMED UNCONTROLLED AND THEREFORE NOT NECESSARILY THE LATEST REVISION.
- ALL INFORMATION REMAINS THE PROPERTY OF THE COMPANY.

GENERAL ARRANGEMENT

P024AVR3SA-LTS P030AVR3SA-LTS P035AVR3SA-LTS
P040AVR3SA-LTS P045AVR3SA-LTS

www.apacair.com.au

ABN: 74 005 138 769

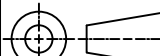
REVISION		REVISED NAMEPLATE WITH APAC DETAILS			
 ATLANTIC DR. KEYSBOROUGH VIC 3173 1300 555 545		DRAWN	MT	DRAWING No.	A4
	DATE	26.11.13	GAD0005		
	SCALE	N.T.S.			
	CHECKED	HA	APP'D.	CM	REV.

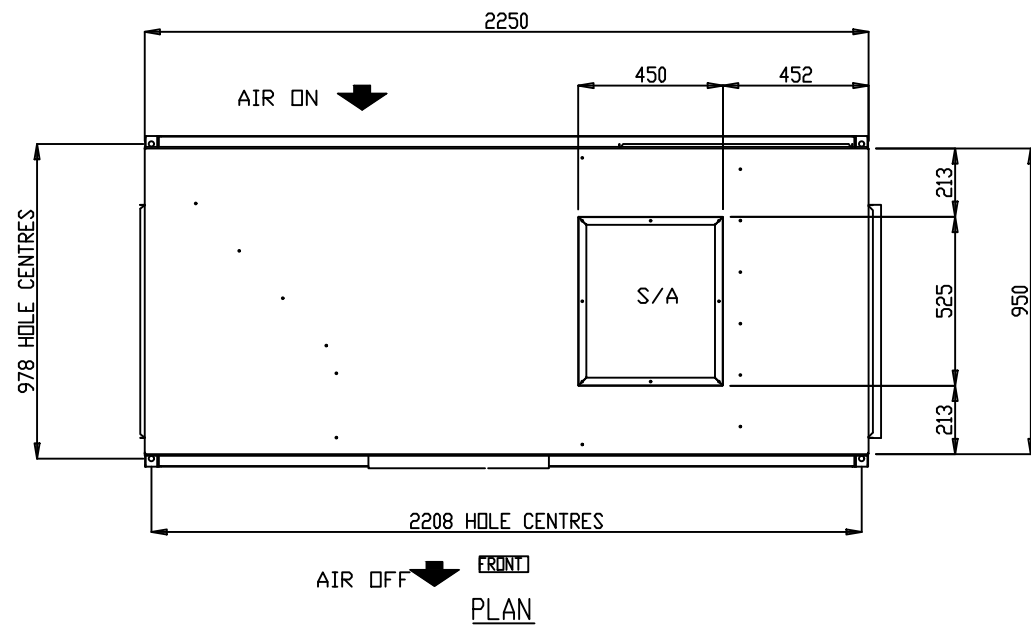

- NOTES:**
1. GENERAL ARRANGEMENT OF A VERTICAL AIR COOLED PACKED UNIT
 2. POWER AND FIELD CABLE ENTRIES, 1 x 32 ϕ AND 2 x 25 ϕ (BOTH SIDES)
 3. ELECTRICAL PANEL LOCATED BEHIND SERVICE ACCESS
 4. CONDENSATE OUTLET 25 ϕ
 5. UNIT BASE 4 x 16 ϕ FIXING POINTS
 6. UNIT HAS 4 x 25.4 ϕ LIFTING POINTS
 7. UNIT CONFIGURATION IS TOP RIGHT SUPPLY, SIDE RIGHT RETURN, OTHER CONFIGURATIONS AVAILABLE.

DIMENSION	APH024-035	APH040-045
A	1145	1600
B	700	245

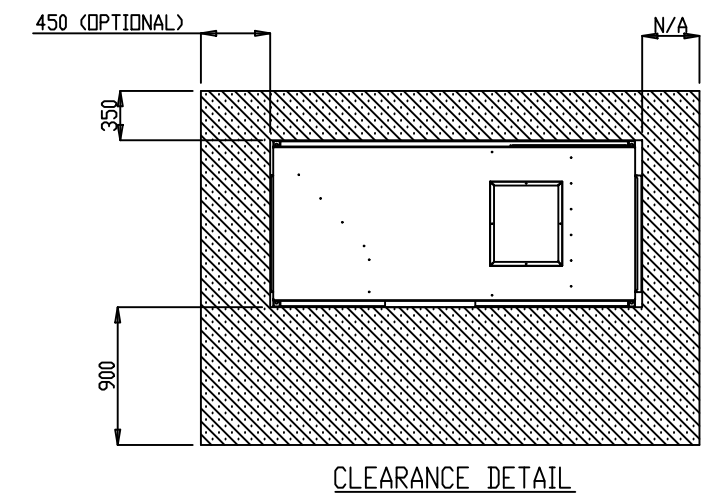
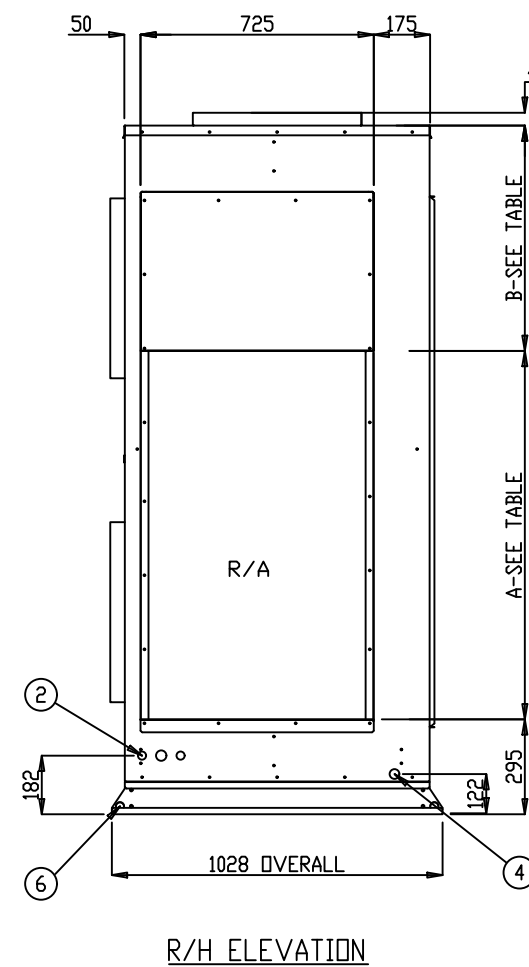
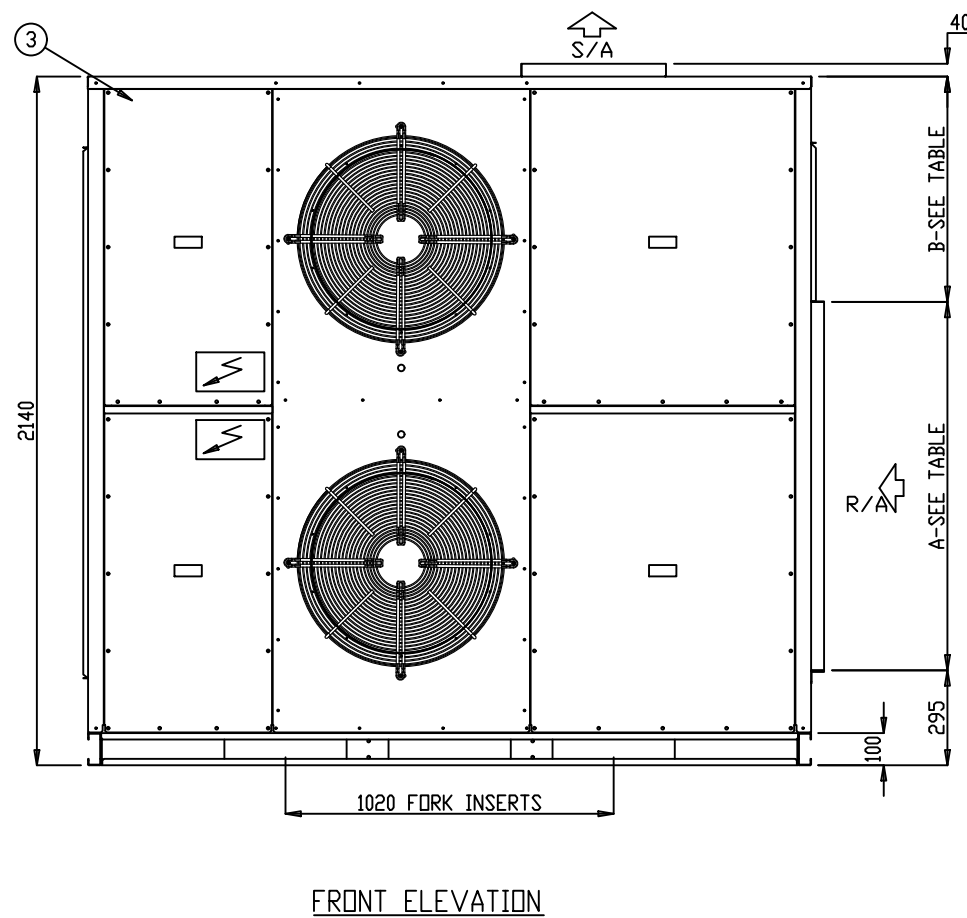

- ALL DIMENSIONS IN mm.
- GENERAL TOLERANCE ± 1 mm.
- DO NOT SCALE DRAWING.
- MASTER DRAWINGS ARE HELD ELECTRONICALLY. ANY COPY IS DEEMED UNCONTROLLED AND THEREFORE NOT NECESSARILY THE LATEST REVISION.
- ALL INFORMATION REMAINS THE PROPERTY OF THE COMPANY.

GENERAL ARRANGEMENT

P024AVR3SA-RTS P030AVR3SA-RTS P035AVR3SA-RTS
P040AVR3SA-RTS P045AVR3SA-RTS

www.apacair.com.au

ABN: 74 005 138 769

REVISION	REVISED NAMEPLATE WITH APAC DETAILS			
 ATLANTIC DR. KEYSBOROUGH VIC 3173 1300 555 545	DRAWN	MT	DRAWING No.	A4
	DATE	26.11.13	GAD0006	
	SCALE	N.T.S.		
	CHECKED	HA	APP'D.	CM

TECHNICAL DATA SHEET

MODEL NUMBER	P024AVR3SA-	P030AVR3SA-	P035AVR3SA-	P040AVR3SA-	P045AVR3SA-		
MEPS REGISTRATION NUMBER	AAC3283	AAC3285	AAC3278	AAC3284	AAC3279		
CONDENSER SECTION	CAPACITY						
	Cooling	kW TOTAL*	25.14	31.00	34.13	39.78	45.27
		kW SENSIBLE*	18.86	25.25	27.06	31.25	35.00
		EER (kW / ikW)*	3.59	3.60	3.44	3.40	3.27
	Heating	kW TOTAL	23.80	30.20	34.25	40.09	43.53
		COP	3.66	3.60	3.85	3.61	3.71
	CAPACITY STEPS (%)		50/100	50/100	50/100	50/100	50/100
	COMPRESSOR						
	TYPE	SCROLL	SCROLL	SCROLL	SCROLL	SCROLL	
	STARTER TYPE	D.O.L (Opt Soft/Start)	D.O.L (Opt Soft/Start)	D.O.L (Opt Soft/Start)	D.O.L (Opt Soft/Start)	D.O.L (Opt Soft/Start)	
	PHASE	3Ø	3Ø	3Ø	3Ø	3Ø	
	No. OFF	2	2	2	2	2	
	PROTECTION DEVICES	HP SWITCH, LP SWITCH, MOTOR OVERLOAD'S					
	ALL COMPRESSORS HAVE	CRANKCASE HEATER					
	FAN						
	TYPE	AXIAL	AXIAL	AXIAL	AXIAL	AXIAL	
	ikW (MAX INPUT)	0.39	0.39	0.39	0.60	0.60	
	PHASE	1Ø	1Ø	1Ø	1Ø	1Ø	
	No. OFF	2	2	2	2	2	
	FAN SPEED CONTROL	VARIABLE SPEED	VARIABLE SPEED	VARIABLE SPEED	VARIABLE SPEED	VARIABLE SPEED	
	HEAT EXCHANGER						
	TYPE	PLATE FIN COIL	PLATE FIN COIL	PLATE FIN COIL	PLATE FIN COIL	PLATE FIN COIL	
	NOM. AIRFLOW l/s	-	-	-	-	-	
	REFRIGERANT SYSTEM						
TYPE	R410A						
CHARGE PER CIRCUIT (KG)	3.95	5.3	5.7	7.3	6.8		
No. OF CIRCUITS	2	2	2	2	2		
REFRIGERANT CONTROL	TXV						
ALL SYSTEMS INCLUDE	DRIERS & SIGHT GLASSES						
EVAPORATOR SECTION	FAN						
	TYPE	CENTRIFUGAL	CENTRIFUGAL	CENTRIFUGAL	CENTRIFUGAL	CENTRIFUGAL	
	ikW (MAX INPUT)	2.73	2.73	2.73	1.7	1.7	
	PHASE	3Ø	3Ø	3Ø	3Ø	3Ø	
	No. OFF	1	1	1	2	2	
	FAN SPEED CONTROL	VARIABLE SPEED	VARIABLE SPEED	VARIABLE SPEED	VARIABLE SPEED	VARIABLE SPEED	
	HEAT EXCHANGER						
	TYPE	PLATE FIN COIL	PLATE FIN COIL	PLATE FIN COIL	PLATE FIN COIL	PLATE FIN COIL	
NOM. AIRFLOW l/s	1250	1670	1750	1985	2235		
EXT STATIC pa	100						
COMBINED SECTIONS	ELECTRICAL						
	MAINS POWER	415v / 3Ø / 50hz	415v / 3Ø / 50hz	415v / 3Ø / 50hz	415v / 3Ø / 50hz	415v / 3Ø / 50hz	
	H.P. CUT OUT / IN kPa	4500 / 3450	4500 / 3450	4500 / 3450	4500 / 3450	4500 / 3450	
	L.P. CUT OUT / IN kPa	175 / 345	175 / 345	175 / 345	175 / 345	175 / 345	
	NOM. R.L.A. (TOTAL SYSTEM)	13.9	16.1	19.8	21.2	23.5	
	MAX. F.L.A. (TOTAL SYSTEM)	23.8	28.4	31.4	40.5	40.5	
	GENERAL						
	CABINET	GALVANISED SHEET STEEL					
	INSULATION	ALUMINIUM FOIL FACED POLYETHYLENE ACOUSTIC INSULATION					
	EXTERNAL FINISH	POLYESTER POWDER COAT - COLOUR LIGHT GREY AS STANDARD - OPTIONS AVAILABLE					
	DIMENSIONS						
	H X W X D (mm)	2140 X 2250 X 950					
	WEIGHT						
	OPERATING KG	570	580	590	610	620	
SHIPPING KG	575	585	595	615	625		
NOISE LEVELS (Based on condenser fan's sound data)							
Sound Power db(A)	66.5	66.5	66.5	68.7	68.7		

Note: Tested in accordance with AS/NZS3823.1.2

*Performance excludes ikW of evaporator fan motor.

R.L.A - Run Load Amps are based on current drawn at nominal conditions

F.L.A - Full Load Amps are based on the overload settings [Max Current] of all Compressor and Fan Motor(s).

Date	Document #	Approved By	Revision
31/5/18	TDS0015	CM	F

NOTE: Due to continuous improvement Rinnai Australia Pty Ltd reserve the right to change details without notice.

FAN PERFORMANCE CURVE

P045AVR3SA-

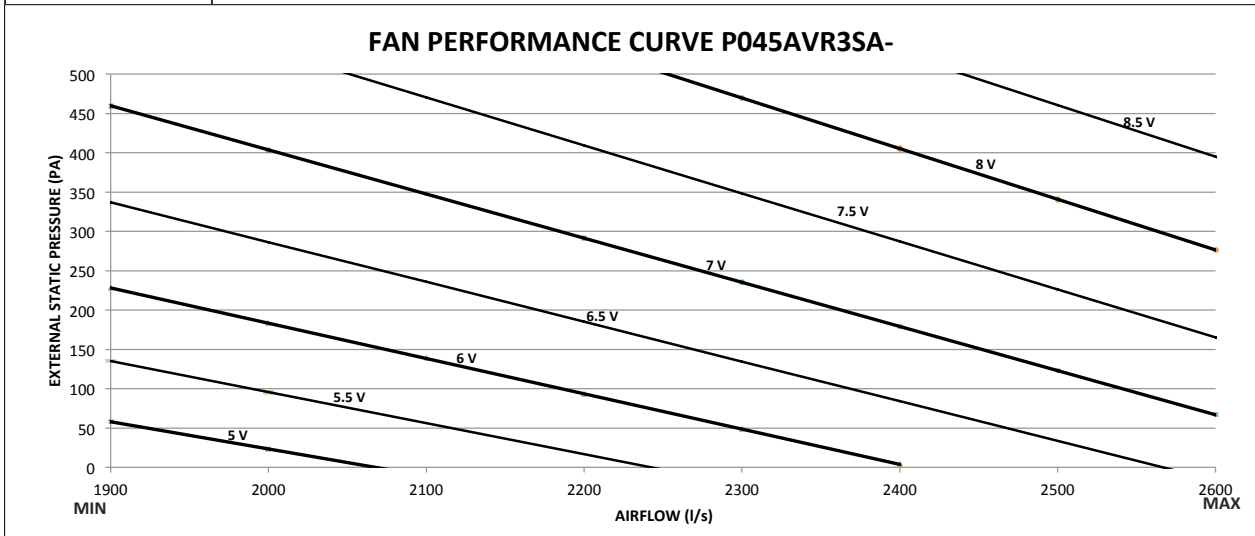

Note:

1. 5V, 5.5 V, 6V, 6.5V, 7V, 7.5V, 8V and 8.5V represents potentiometer voltage. Potentiometer can be adjusted to achieve desired flowrates.
2. Potentiometer voltage can be varied infinitely between 0 to 10V.

Date	Document #	Approved By	Revision
29.05.18	FPC0057	CM	B

NOTE: Due to continuous improvement Rinnai Australia Pty Ltd reserve the right to change details without notice.



SOUND DATA

MODEL NUMBER

P045AVR3SA-

Outdoor Fan

Sound Power Level dB(A)	Octave band Centre Frequency (Hz), dB						
	125	250	500	1k	2k	4k	8k
68.7	75.6	63.7	64.1	63.2	61.4	58.2	55.3

Indoor Fan

Sound Power Level dB(A)	Air Flow (l/s)	Octave band Centre Frequency (Hz), dB						
		125	250	500	1k	2k	4k	8k
85.6	2236	67	74.3	77.5	81.1	78.4	77.8	76.5

Date	Document #	Approved By	Revision
02.06.18	SD0048	CM	B

NOTE: Due to continuous improvement Rinnai Australia Pty Ltd reserve the right to change details

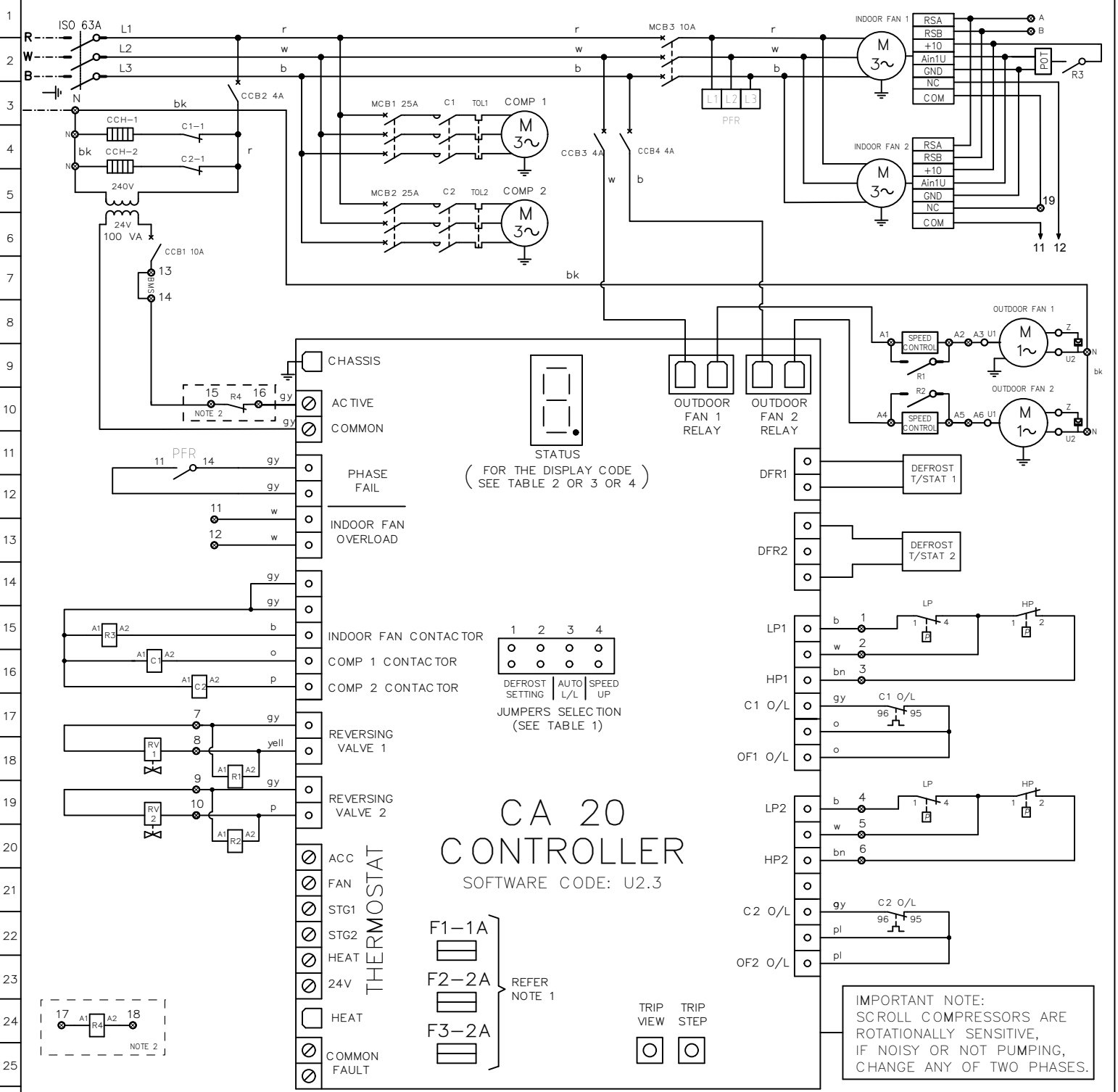

WARNING! THE SOFTWARE OF THE CA20 CONTROLLER IS NOT DESIGNED TO FUNCTION AS A PRIMARY PERSONAL SAFETY DEVICE, AS CONNECTED EQUIPMENT CAN START AUTOMATICALLY WITHOUT WARNING. ALSO, OPENING THERMOSTAT CONTACTS MAY NOT CAUSE THE EQUIPMENT TO STOP. OUTDOOR FAN MOTORS HAVE INTERNAL OVERLOADS AND MAY RESTART AUTOMATICALLY.

- NOTES:
1. TIME DELAY GLASS FUSES ON THE PCB CONTROLLER ARE THE FOLLOWING:
 - F1 PROTECTS THE THERMOSTAT CIRCUIT.
 - F2 PROTECTS THE REVERSING VALVE CIRCUITS AND THE "HEAT" OUTPUT. THIS FUSE F2 ALSO SUPPLIES FUSE F1.
 - F3 PROTECTS BOTH COMPRESSOR CONTACTOR CIRCUITS AND THE INDOOR FAN CONTACTOR CIRCUIT.
 2. OPTIONAL FIRE ALARM RELAY
 3. HP CUT OUT & LP CUT OUT - AUTO RESET.
 4. THERMAL OVERLOAD RELAYS - AUTO RESET, UNLESS OTHERWISE STATED.
 5. DO NOT CONNECT ANY ADDITIONAL EQUIPMENT TO THE CONTROL TRANSFORMER OTHER THAN THE EQUIPMENT SHOWN ON THE ELECTRICAL DRAWING.
 6. ALL FIELD WIRING IS THE RESPONSIBILITY OF THE INSTALLING CONTRACTOR AND MUST COMPLY WITH AS/NZS 3000 AND LOCAL RULES.
 7. SOFTWARE CODE MUST BE CHECKED AFTER REPLACEMENT OF THE CA-20 CONTROLLER BY CHECKING THE DISPLAY CODE ON THE 7 SEGMENT DISPLAY AFTER THE CONTROLLER IS ACTIVATED.

JUMPERS SELECTION	DEFROST INTERVAL TIME SETTING	JUMPERS SELECTION	AUTO LEAD/LAG	JUMPERS SELECTION	SPEED UP
	15 min		OFF		OFF
	FACTORY SETTING 30 min		ON		ON
	45 min		ON		ON

UNIT MUST BE SWITCHED OFF BEFORE CHANGING THE JUMPER SELECTION

LEGEND		LEGEND		COLOUR CODE		COMPRESSOR (EACH)		MODEL: P045AVR3SA				
	TERMINAL SWITCHBOARD	TOL	THERMAL OVERLOAD RELAY	r	RED	KW	5.52	OPTIONS DESCRIPTION STANDARD				
	TERMINAL OF FIELD WIRING	R	RELAY CONTACTOR	w	WHITE	RATED CURRENT	15.00					
	CONTROL PARAMETER MAINS/CONTROL WIRING	C	COMPRESSOR	bk	BLACK	O/L SETTING	16.50	DATE 28/06/2018				
	CRANK CASE HEATER	ISO	ISOLATOR SWITCH	bn	BROWN	FANS (EACH) KW	FLA					
	PHASE FAILURE RELAY	MCB	MINIATURE CIRCUIT BREAKER	o	ORANGE	OUTDOOR	0.60	2.62	DWN	S.P	APPD	ENG
	REVERSING VALVE	CCB	CONTROL CIRCUIT BREAKER	pl	PINK	INDOOR	1.70	2.60	REV	B	GRID	B143
	HIGH PRESSURE SWITCH	O/L	OVERLOAD	gy	GREY			DWC No. EWS02129				
	LOW PRESSURE SWITCH	POT	POTENTIOMETER	yell	YELLOW							

DATE 28/06/2018

DWN S.P APPD ENG

REV B GRID B143

DWC No. EWS02129