



VPU HANDING CONFIRMATION AND OPTIONAL LIDS

VERTICAL PACKAGED UNITS (VPU)

MODELS	P012, 015, 018, 020 & 023 AVR3SA-
GENERAL	This document details the airside configurations available on 012-023 VPU models.
SOURCING	Standard configuration is LTT. Optional airside configurations to be specified at time of order.
HOW TO USE THIS DOCUMENT	<ol style="list-style-type: none"> 1. Choose if the supply air fan position is required on the left or right. 2. Circle the required supply air outlet. 3. Circle the required return air inlet. 4. Complete the information at the bottom of this document and return to your APAC representative.

STANDARD LID (REPLACEMENT FOR FRIGIPOL OR APAC S12, 15, 17, 20 & PRIME AIR PA145)	OPTION A LID (REPLACEMENT FOR EMAIL UE050, M15 & APAC P015)
---	---

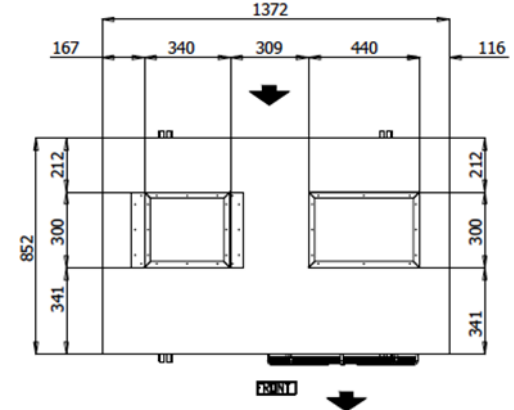
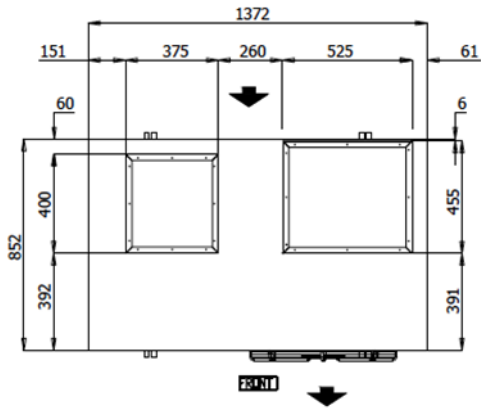

OPTION B LID (REPLACEMENT FOR EMAIL MM140)	
--	--

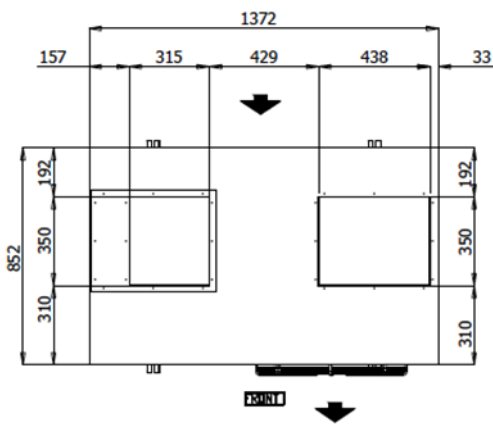

AIRSIDE CONNECTIONS

PLEASE CIRCLE THE LID TYPE, SUPPLY FAN POSITION & SUPPLY AIR AND RETURN AIR CONNECTIONS YOU REQUIRE

LID TYPE	STANDARD LID	OPTION A LID	OPTION B LID	
SUPPLY FAN POSITION	LEFT	RIGHT		
SUPPLY AIR CONNECTION	TOP	REAR		
RETURN AIR CONNECTION	TOP	REAR	SIDE	
EXTENSION FEET REQUIRED	YES	NO		

CUSTOMER TO COMPLETE AND RETURN

CUSTOMER	PROJECT	UNIT REF	NAME / SIGN	DATE

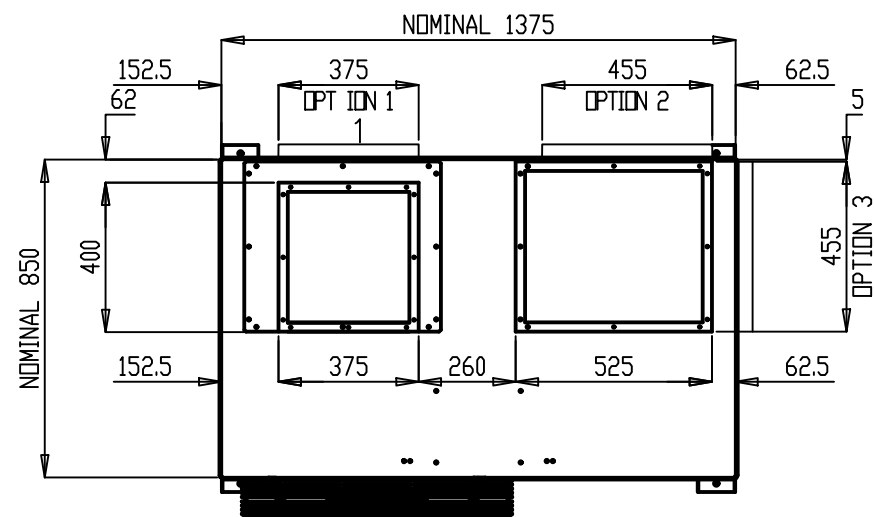

AIR OFF PLAN

NOTE: SEE SHEET 2 FOR OPTIONAL LID DIMENSIONS

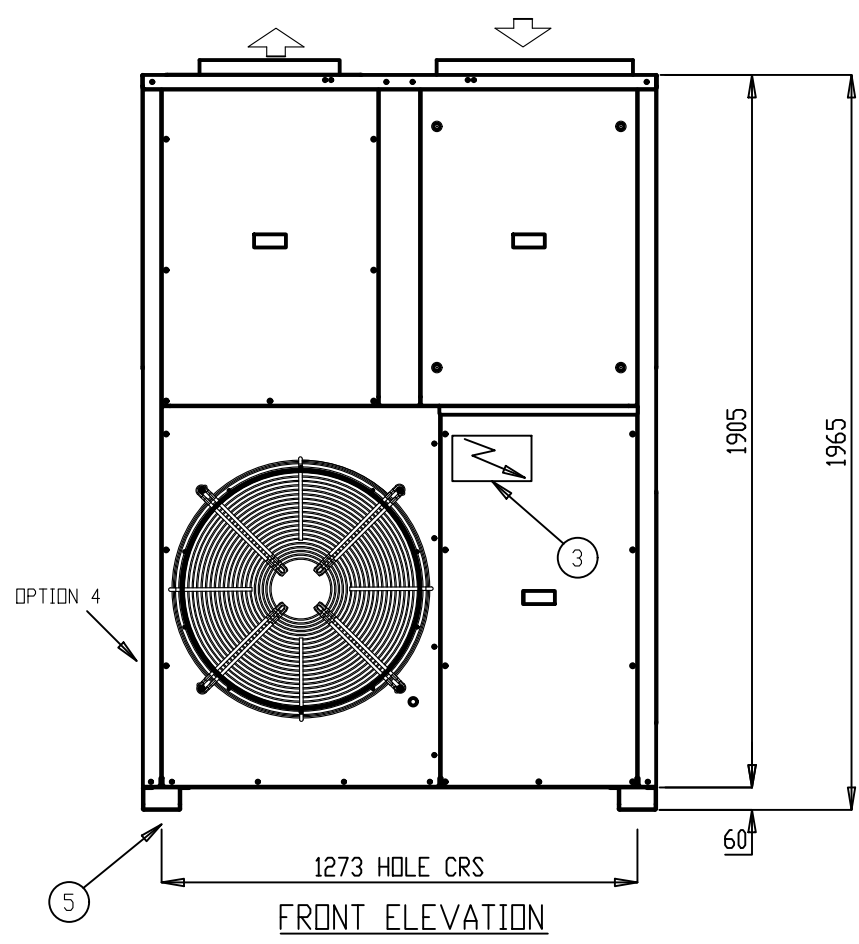

FRONT ELEVATION

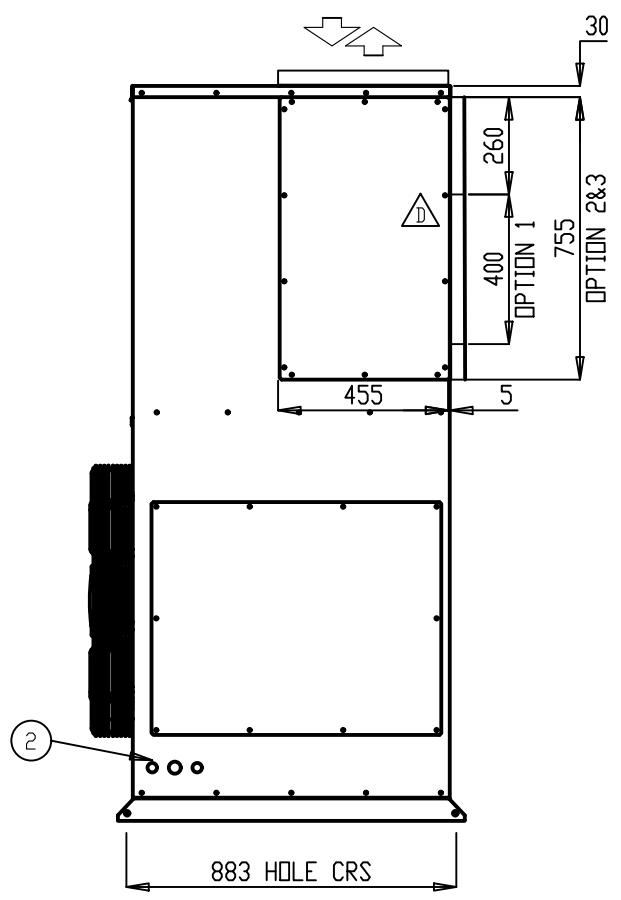

R/H ELEVATION

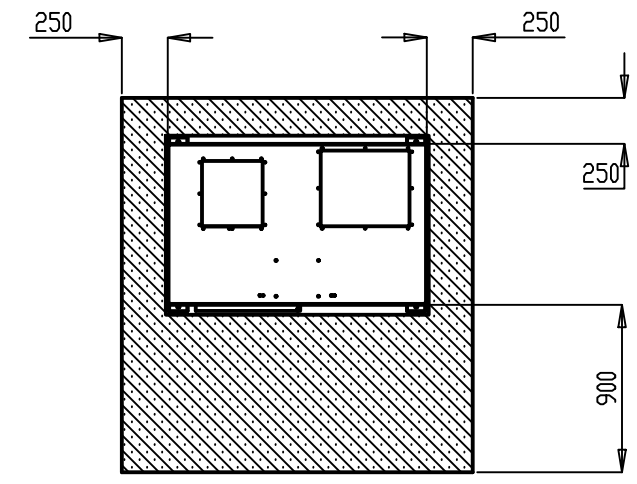

CLEARANCE DETAIL

- NOTES:
1. GENERAL ARRANGEMENT OF A VERTICAL PACKAGED UNIT
 2. POWER AND FIELD CABLE ENTRY, 1X 32 AND 2 X 25
 3. ELECTRICAL PANEL LOCATED BEHIND SERVICE ACCESS DOOR
 4. CONDENSATE OUTLET 20mm
 5. UNIT BASE 4 x 12Ø FIXING POINTS
 6. SUPPLY AIR IS TOP LEFT AS STANDARD. OR OPTION 1 REAR SUPPLY
RETURN AIR IS TOP RIGHT AS STANDARD OR OPTION 2. REAR RETURN
OPTION 3. SIDE RETURN
 7. OUTDOOR FAN IS ON FRONT AS STANDARD, OR OPTION 4 SIDE AIR OFF

- ALL DIMENSIONS IN mm.
- GENERAL TOLERANCE ±1mm.
- DO NOT SCALE DRAWING.
- MASTER DRAWINGS ARE HELD ELECTRONICALLY. ANY COPY IS DEEMED UNCONTROLLED AND THEREFORE NOT NECESSARILY THE LATEST REVISION.
- ALL INFORMATION REMAINS THE PROPERTY OF THE COMPANY.

GENERAL ARRANGEMENT

Sheet 1 of 2

P020AVR3SA-LTT P023AVR3SA-LTT

www.apacair.com.au

ABN: 74 005 138 769

REVISION	ADDED OPTION 1 DIMENSIONS TO R/H ELEVATION			
 ATLANTIC DR. KEYSBOROUGH VIC 3173 1300 555 545 by Rinnai	DRAWN	MT	DRAWING No. A4	
	DATE	29.05.16	GAD0066	
	SCALE	N.T.S.		
	CHECKED	HA	APP'D.	CM

1 2 3 4 5 6

A

A

B

B

C

C

D

D

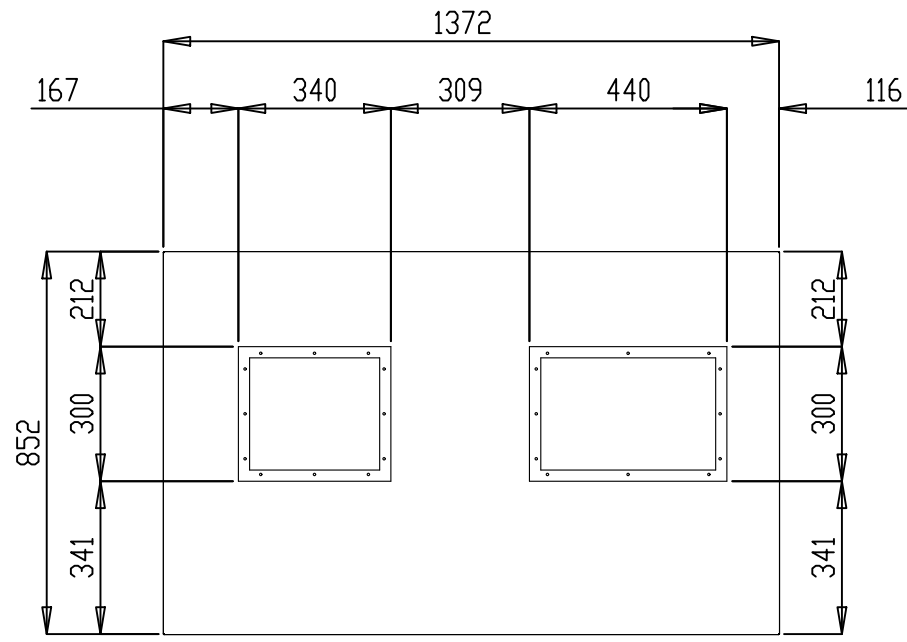

FRONT
PLAN-OPTION A LID - LEFT HAND SUPPLY

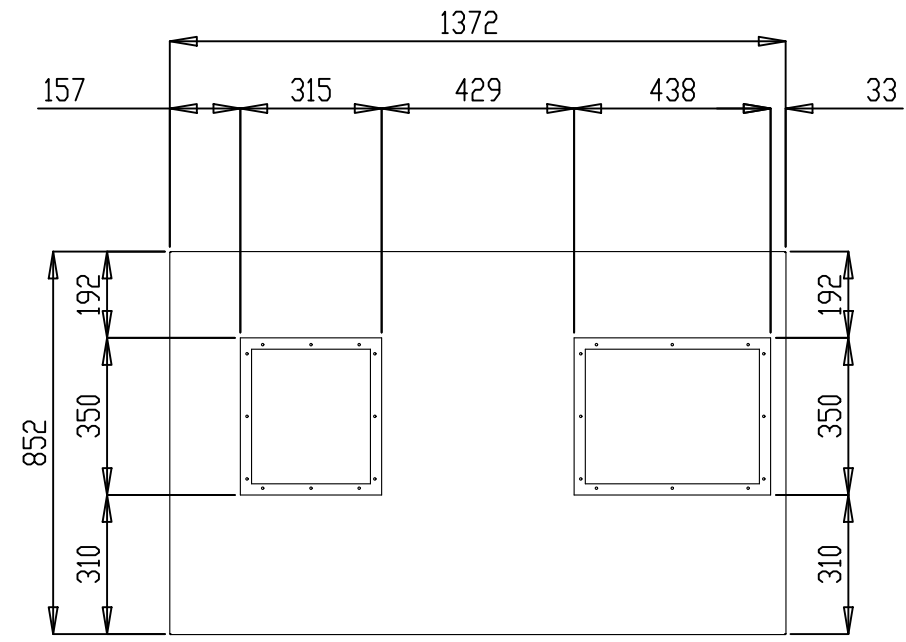

FRONT
PLAN-OPTION B LID - LEFT HAND SUPPLY

- ALL DIMENSIONS IN mm.
- GENERAL TOLERANCE $\pm 1\text{mm}$.
- DO NOT SCALE DRAWING.
- MASTER DRAWINGS ARE HELD ELECTRONICALLY. ANY COPY IS DEEMED UNCONTROLLED AND THEREFORE NOT NECESSARILY THE LATEST REVISION.
- ALL INFORMATION REMAINS THE PROPERTY OF THE COMPANY.

GENERAL ARRANGEMENT
Sheet 2 of 2

P020AVR3SA-LTT P023AVR3SA-LTT

www.apacair.com.au ABN: 74 005 138 769

REVISION	ADDED OPTION 1 DIMENSIONS TO R/H ELEVATION				
 ATLANTIC DR. KEYSBOROUGH VIC 3173 1300 555 545 by Rinnai	DRAWN	MT	DRAWING No.		A4
	DATE	29.05.16	GAD0066		
	SCALE	N.T.S.			
	CHECKED	HA	APP'D.	CM	REV.

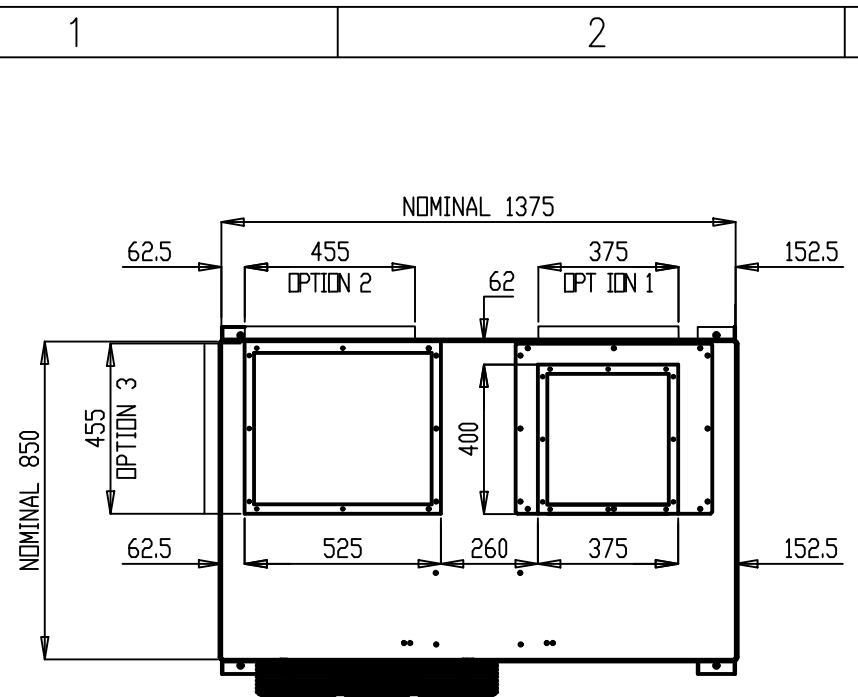

AIR OFF PLAN

NOTE: SEE SHEET 2 FOR OPTIONAL LID DIMENSIONS

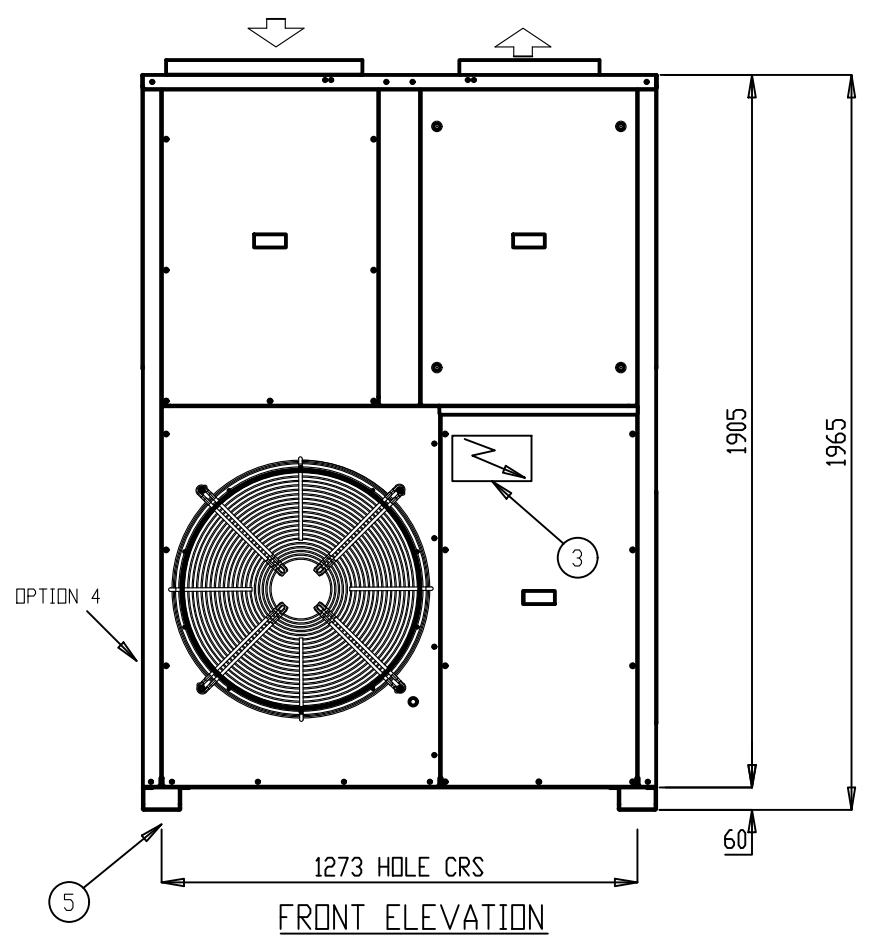

FRONT ELEVATION

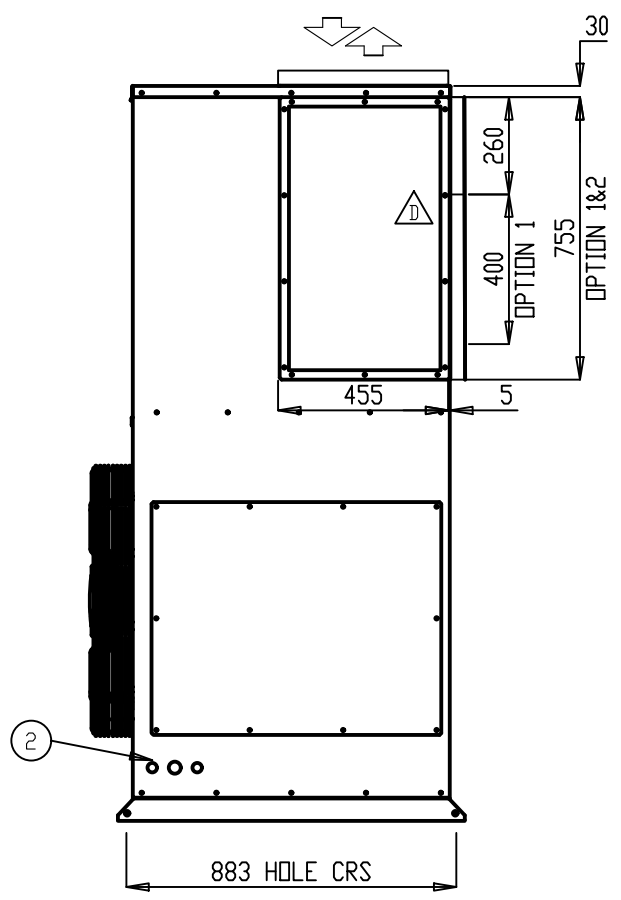

R/H ELEVATION

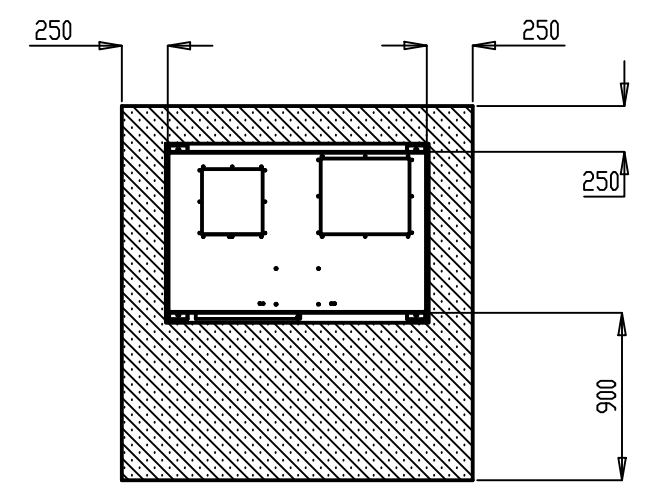

CLEARANCE DETAIL

NOTES:

1. GENERAL ARRANGEMENT OF A VERTICAL PACKAGED UNIT
2. POWER AND FIELD CABLE ENTRY, 1X 32 AND 2 X 25
3. ELECTRICAL PANEL LOCATED BEHIND SERVICE ACCESS DOOR
4. CONDENSATE OUTLET 20mm
5. UNIT BASE 4 x 12Ø FIXING POINTS
6. SUPPLY AIR IS TOP LEFT AS STANDARD. OR OPTION 1 REAR SUPPLY
RETURN AIR IS TOP RIGHT AS STANDARD OR OPTION 2. REAR RETURN
OPTION 3. SIDE RETURN
7. OUTDOOR FAN IS ON FRONT AS STANDARD, OR OPTION 4 SIDE AIR OFF

- ALL DIMENSIONS IN mm.
- GENERAL TOLERANCE ±1mm.
- DO NOT SCALE DRAWING.
- MASTER DRAWINGS ARE HELD ELECTRONICALLY. ANY COPY IS DEEMED UNCONTROLLED AND THEREFORE NOT NECESSARILY THE LATEST REVISION.
- ALL INFORMATION REMAINS THE PROPERTY OF THE COMPANY.

GENERAL ARRANGEMENT
Sheet 1 of 2

P020AVR3SA-RTT P023AVR3SA-RTT

www.apacair.com.au

ABN: 74 005 138 769

REVISION	ADDED OPTION 1 DIMENSIONS TO R/H ELEVATION			
 ATLANTIC DR. KEYSBOROUGH VIC 3173 1300 555 545 by Rinnai	DRAWN	MT	DRAWING No.	A4
	DATE	29.05.16	GAD0067	
	SCALE	N.T.S.		
	CHECKED	HA	APP'D.	CM

1

2

3

4

5

6

A

B

C

D

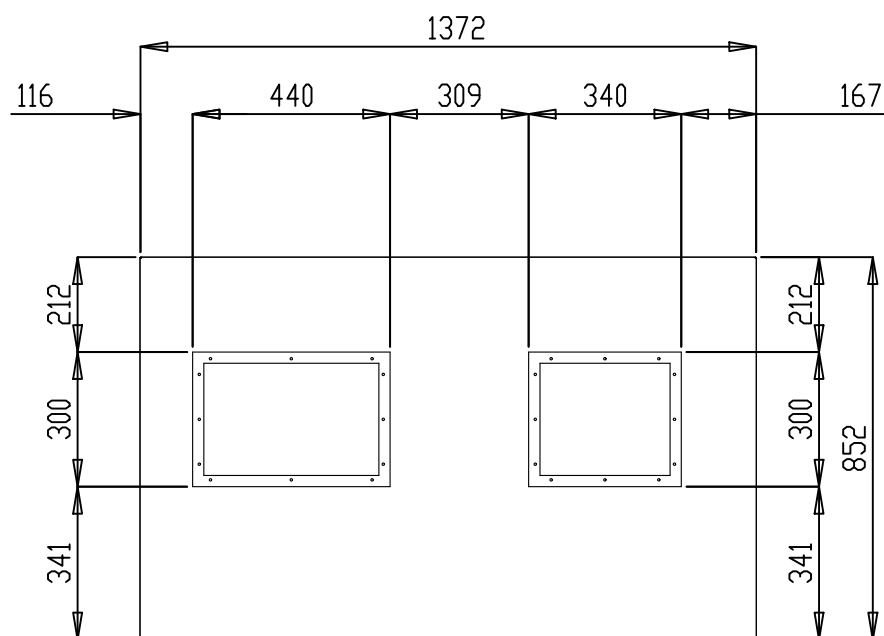

FRONT
PLAN-OPTION A LID - RIGHT HAND SUPPLY

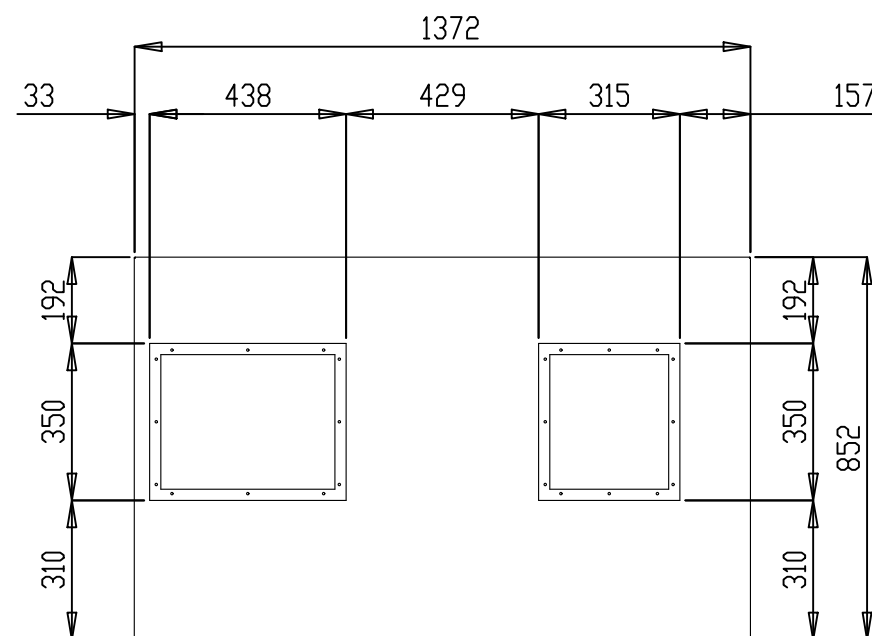

FRONT
PLAN-OPTION B LID - RIGHT HAND SUPPLY

- ALL DIMENSIONS IN mm.
- GENERAL TOLERANCE $\pm 1\text{mm}$.
- DO NOT SCALE DRAWING.
- MASTER DRAWINGS ARE HELD ELECTRONICALLY. ANY COPY IS DEEMED UNCONTROLLED AND THEREFORE NOT NECESSARILY THE LATEST REVISION.
- ALL INFORMATION REMAINS THE PROPERTY OF THE COMPANY.

GENERAL ARRANGEMENT

Sheet 2 of 2

P020AVR3SA-RTT P023AVR3SA-RTT

www.apacair.com.au

ABN: 74 005 138 769

REVISION		ADDED OPTION 1 DIMENSIONS TO R/H ELEVATION			
 apac <small>by Rinnai</small>	 ATLANTIC DR. KEYSBOROUGH VIC 3173 1300 555 545	DRAWN	MT	DRAWING No.	A4
		DATE	29.05.16	GAD0067	
		SCALE	N.T.S.		
		CHECKED	HA	APP'D.	CM

TECHNICAL DATA SHEET

MODEL NUMBER	P012AVR3SA-	P015AVR3SA-	P018AVR3SA-	P020AVR3SA-	P023AVR3SA-		
MEPS REGISTRATION NUMBER	AAC3310	AAC3305	AAC3309	AAC3317	AAC3308		
CONDENSER SECTION	CAPACITY						
	Cooling	kW TOTAL*	12.30	15.50	17.50	20.00	22.80
		kW SENSIBLE*	9.42	12.50	13.50	15.30	17.50
		EER (kW / ikW)*	3.52	3.60	3.43	3.39	3.28
	Heating	kW TOTAL	11.90	14.70	16.70	20.60	22.50
		COP	3.66	3.87	3.71	3.81	3.63
	CAPACITY STEPS (%)		0/100	0/100	0/100	0/100	0/100
	COMPRESSOR						
	TYPE		SCROLL	SCROLL	SCROLL	SCROLL	SCROLL
	STARTER TYPE		D.O.L (Opt Soft/Start)	D.O.L (Opt Soft/Start)	D.O.L (Opt Soft/Start)	D.O.L (Opt Soft/Start)	D.O.L (Opt Soft/Start)
	PHASE		3∅	3∅	3∅	3∅	3∅
	No. OFF		1	1	1	1	1
	PROTECTION DEVICES		HP SWITCH, LP SWITCH, MOTOR OVERLOAD'S				
	ALL COMPRESSORS HAVE		CRANKCASE HEATER				
	FAN						
	TYPE		AXIAL	AXIAL	AXIAL	AXIAL	AXIAL
	ikW (MAX INPUT)		0.39	0.39	0.39	0.60	0.60
	PHASE		1∅	1∅	1∅	1∅	1∅
	No. OFF		1	1	1	1	1
	FAN SPEED CONTROL		VARIABLE SPEED	VARIABLE SPEED	VARIABLE SPEED	VARIABLE SPEED	VARIABLE SPEED
	HEAT EXCHANGER						
	TYPE		PLATE FIN COIL	PLATE FIN COIL	PLATE FIN COIL	PLATE FIN COIL	PLATE FIN COIL
	NOM. AIRFLOW l/s		-	-	-	-	-
	REFRIGERANT SYSTEM						
	TYPE		R410A				
CHARGE PER CIRCUIT (KG)		3.95	5.3	5.7	7.3	6.8	
No. OF CIRCUITS		1	1	1	1	1	
REFRIGERANT CONTROL		TXV					
ALL SYSTEMS INCLUDE		DRIERS & SIGHT GLASSES					
EVAPORATOR SECTION	FAN						
	TYPE		CENTRIFUGAL	CENTRIFUGAL	CENTRIFUGAL	CENTRIFUGAL	CENTRIFUGAL
	ikW (MAX INPUT)		1.7	1.7	1.7	1.7	1.7
	PHASE		3∅	3∅	3∅	3∅	3∅
	FAN SPEED CONTROL		VARIABLE SPEED	VARIABLE SPEED	VARIABLE SPEED	VARIABLE SPEED	VARIABLE SPEED
	HEAT EXCHANGER						
	TYPE		PLATE FIN COIL	PLATE FIN COIL	PLATE FIN COIL	PLATE FIN COIL	PLATE FIN COIL
	NOM. AIRFLOW l/s		625	835	875	990	1120
EXT STATIC pa		100					
COMBINED SECTIONS	ELECTRICAL						
	MAINS POWER		415v / 3∅ / 50hz	415v / 3∅ / 50hz	415v / 3∅ / 50hz	415v / 3∅ / 50hz	415v / 3∅ / 50hz
	H.P. CUT OUT / IN kPa		4500 / 3450	4500 / 3450	4500 / 3450	4500 / 3450	4500 / 3450
	L.P. CUT OUT / IN kPa		175 / 345	175 / 345	175 / 345	175 / 345	175 / 345
	NOM. R.L.A. (TOTAL SYSTEM)		5.60	6.88	8.50	9.72	12.40
	MAX. F.L.A. (TOTAL SYSTEM)		12.40	14.70	16.20	20.20	20.20
	GENERAL						
	CABINET		GALVANISED SHEET STEEL				
	INSULATION		ALUMINIUM FOIL FACED POLYETHYLENE ACOUSTIC INSULATION				
	EXTERNAL FINISH		POLYESTER POWDER COAT - COLOUR LIGHT GREY AS STANDARD - OPTIONS AVAILABLE				
	DIMENSIONS						
	H X W X D (mm)		1579 x 1370 x 850	1579 x 1370 x 850	1579 x 1370 x 850	1965 x 1370 x 850	1965 x 1370 x 850
	WEIGHT						
	OPERATING KG		250	270	270	300	300
	SHIPPING KG		255	275	275	362	372
NOISE LEVELS [Based on condenser fan's sound data]							
Sound Power db(A)		63.5	63.5	63.5	66.9	66.9	

Note: All units are MEPS complaint. Tested in accordance with AS/NZS 3823.1.2

*Performance excludes ikW of evaporator fan motor.

R.L.A - Run Load Amps are based on current drawn at nominal conditions

F.L.A - Full Load Amps are based on the overload settings [Max Current] of all Compressor and Fan Motor(s).

Date	Document #	Approved By	Revision
27/6/18	TDS0014	CM	H

FAN PERFORMANCE CURVE

P023AVR3SA-

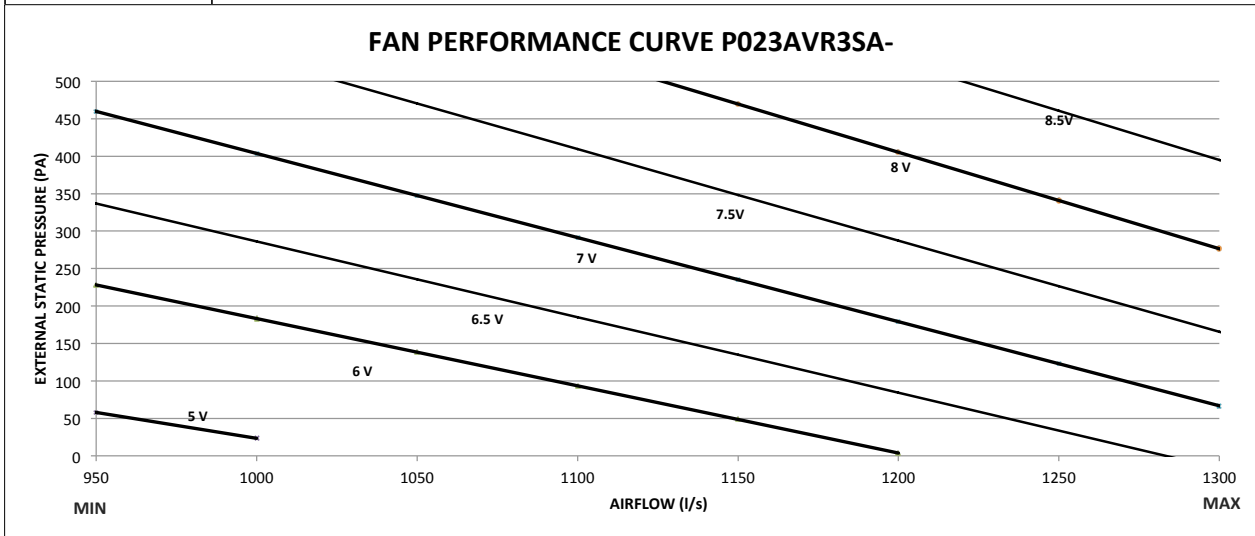

Note:

1. 6V, 6.5V, 7V, 7.5V, 8V, 8.5V and 9V represents potentiometer voltage. Potentiometer can be adjusted to achieve desired flowrates.
2. Potentiometer voltage can be varied infinitely between 0 to 10V.

Date	Document #	Approved By	Revision
29.05.18	FPC0052	CM	B

NOTE: Due to continuous improvement Rinnai Australia Pty Ltd reserve the right to change details without notice.



SOUND DATA

MODEL NUMBER

P023AVR3SA-

Outdoor Fan

Sound Power Level dB(A)	Octave band Centre Frequency (Hz), dB						
	125	250	500	1k	2k	4k	8k
66.9	74.1	61	62.1	61.3	59.5	57	52.8

Indoor Fan

Sound Power Level dB(A)	Air Flow (l/s)	Octave band Centre Frequency (Hz), dB						
		125	250	500	1k	2k	4k	8k
82.8	1120	64	71.6	74.6	78.2	75.5	75.1	73.8

Date	Document #	Approved By	Revision
01.06.18	SD0043	CM	B

NOTE: Due to continuous improvement Rinnai Australia Pty Ltd reserve the right to change details

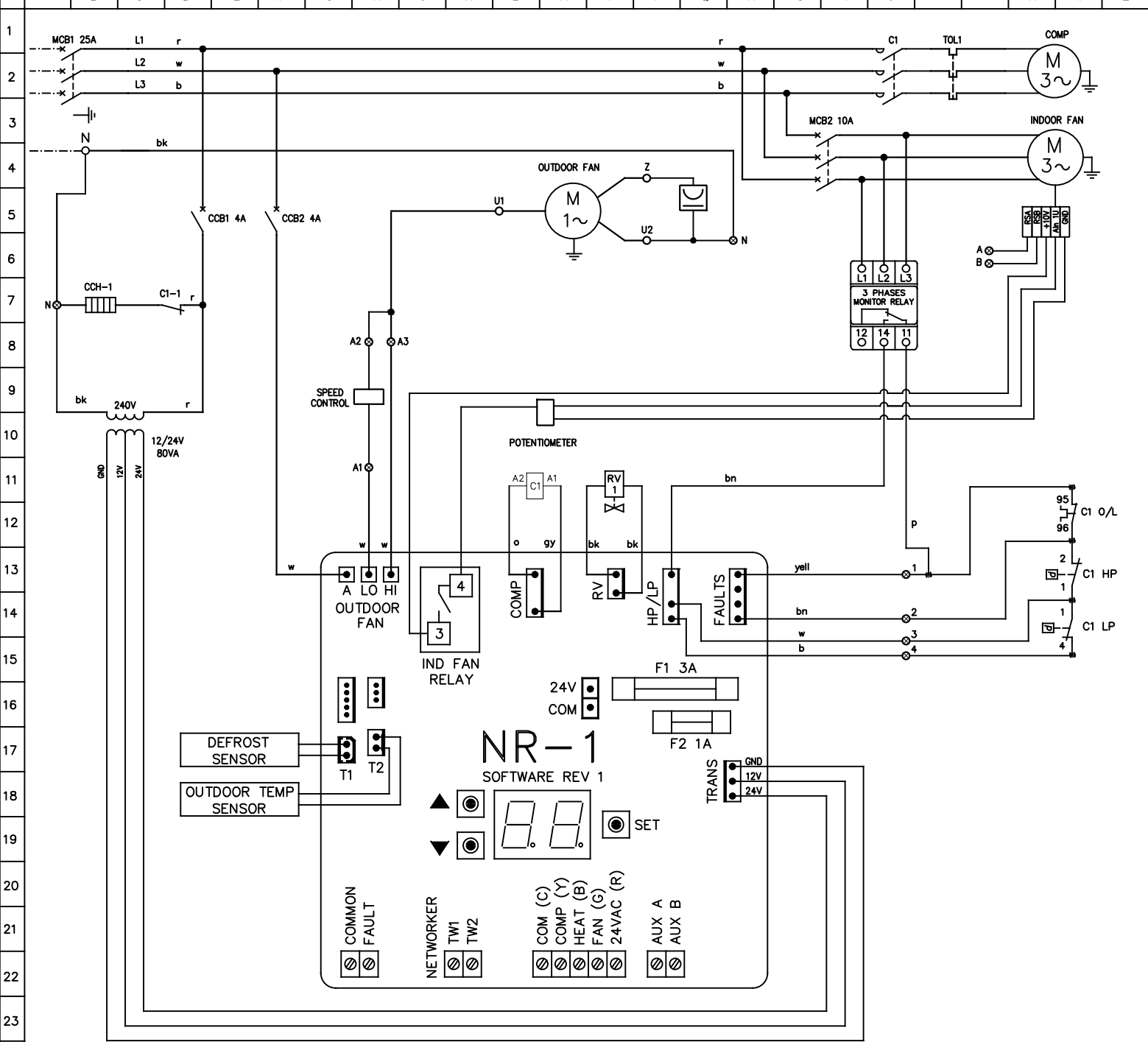

	TYPE	ID	SETTING	
INDOOR FAN OPERATION DURING DEFROST PARAMETER SETTING	INSTALLER	5	1	UPON COMPLETION OF SETTING THE PARAMETERS, SYSTEM (SAFETY SWITCHES, OVERLOADS, LOCKOUT) MUST BE TESTED TO ENSURE CORRECT OPERATION.
		11	1	
FAULT INPUT PARAMETER SETTING	SERVICE	12	0	
		13	0	
		14	1	

- NOTES: 1. THERMAL OVERLOAD RELAYS, HP SWITCH AND LP SWITCH ARE AUTO RESET, UNLESS OTHERWISE STATED.
 2. ALL FIELD WIRING IS THE RESPONSIBILITY OF THE INSTALLING CONTRACTOR, AND MUST COMPLY WITH AS/NZS 3000 AND LOCAL RULES.

WARNING: THE SOFTWARE OF THE NR-1 CONTROLLER IS NOT DESIGNED TO FUNCTION AS A PRIMARY PERSONAL SAFETY DEVICE, AS CONNECTED EQUIPMENT CAN START AUTOMATICALLY WITHOUT WARNING. ALSO OPENING THERMOSTAT CONTACTS OR SWITCHING OFF ON THE NC4 NETWORKER MAY NOT CAUSE THE EQUIPMENT TO STOP. THE ELECTRONIC CONTROLLER HAS A BUILT IN AUTOMATIC RESET FAULT LOCKOUT FUNCTION AND MAY RESTART THE SYSTEM AUTOMATICALLY WITHOUT WARNING.
 OUTDOOR FAN MOTORS HAVE INTERNAL OVERLOADS AND MAY RESTART AUTOMATICALLY.

IMPORTANT NOTE: THE SCROLL COMPRESSOR IS ROTATIONALLY SENSITIVE, IF NOISY OR NOT PUMPING, CHANGE ANY OF TWO PHASES.

LEGEND		LEGEND		COLOUR CODE	COMPRESSOR (EACH)	MODEL: P023AVR3SA	
COMP	COMPRESSOR CONTACTOR	---	FIELD WIRING	r	RED	OPTIONS	
C1	CONTACTOR OVERLOAD	---	MAINS/CONTROL WIRING	w	WHITE		DESCRIPTION
O/L	THERMAL OVERLOAD	---	CONTROL PARAMETER	b	BLUE	REF	
TOL	CRANK CASE HEATER	---	SWITCHBOARD TERMINAL	bk	BLACK	A	STANDARD
CCH.	REVERSING VALVE	⊗	TERMINAL	bn	BROWN		
RV.	HIGH PRESSURE SWITCH	○		o	ORANGE		
HP.	LOW PRESSURE SWITCH			p	PINK		
LP.	MINIATURE CIRCUIT BREAKER			pl	PURPLE		
MCB	BREAKER			gy	GREY		
CCB	CONTROL CIRCUIT BREAKER			yell	YELLOW		
					kw	5.52	
					RATED CURRENT	15.00	
					O/L SETTING	16.50	
					FANS (EACH)	kw	FLA
					OUTDOOR	0.60	2.62
					INDOOR	1.70	2.60



DATE	3/07/2018		
DWN	S.P	APPD	ENG
REV	A	GRID	B115
DWG No.	EWS02109		