



VPU HANDING CONFIRMATION AND OPTIONAL LIDS

VERTICAL PACKAGED UNITS (VPU)

<b>MODELS</b>	P012, 015, 018, 020 & 023 AVR3SA-
<b>GENERAL</b>	This document details the airside configurations available on 012-023 VPU models.
<b>SOURCING</b>	Standard configuration is LTT. Optional airside configurations to be specified at time of order.
<b>HOW TO USE THIS DOCUMENT</b>	<ol style="list-style-type: none"> <li>1. Choose if the supply air fan position is required on the left or right.</li> <li>2. Circle the required supply air outlet.</li> <li>3. Circle the required return air inlet.</li> <li>4. Complete the information at the bottom of this document and return to your APAC representative.</li> </ol>

<b>STANDARD LID</b> (REPLACEMENT FOR FRIGIPOL OR APAC S12, 15, 17, 20 & PRIME AIR PA145)	<b>OPTION A LID</b> (REPLACEMENT FOR EMAIL UE050, M15 & APAC P015)
---	---

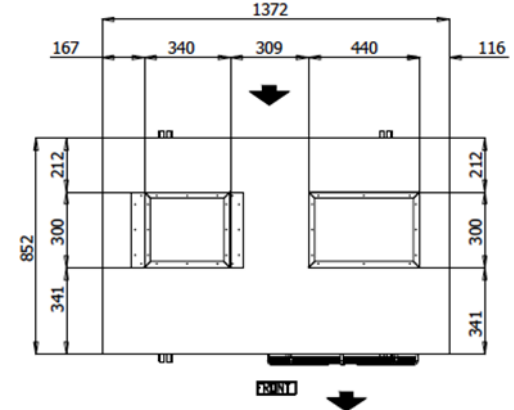
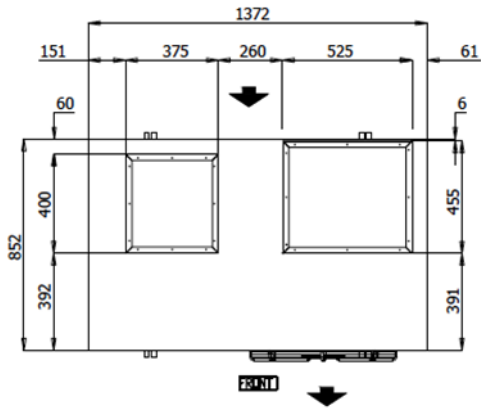

<b>OPTION B LID</b> (REPLACEMENT FOR EMAIL MM140)	
--	--

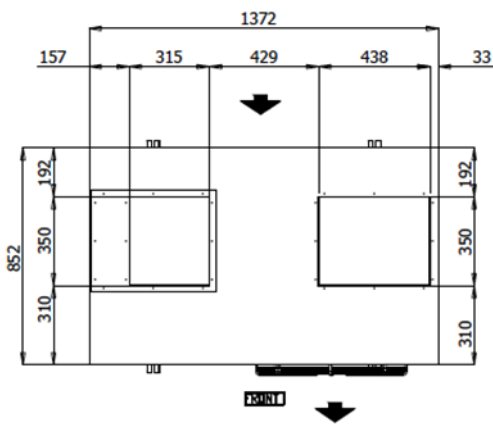

**AIRSIDE CONNECTIONS**

PLEASE CIRCLE THE LID TYPE, SUPPLY FAN POSITION & SUPPLY AIR AND RETURN AIR CONNECTIONS YOU REQUIRE

LID TYPE	STANDARD LID	OPTION A LID	OPTION B LID	
SUPPLY FAN POSITION	LEFT	RIGHT		
SUPPLY AIR CONNECTION	TOP	REAR		
RETURN AIR CONNECTION	TOP	REAR	SIDE	
EXTENSION FEET REQUIRED	YES	NO		

**CUSTOMER TO COMPLETE AND RETURN**

CUSTOMER	PROJECT	UNIT REF	NAME / SIGN	DATE

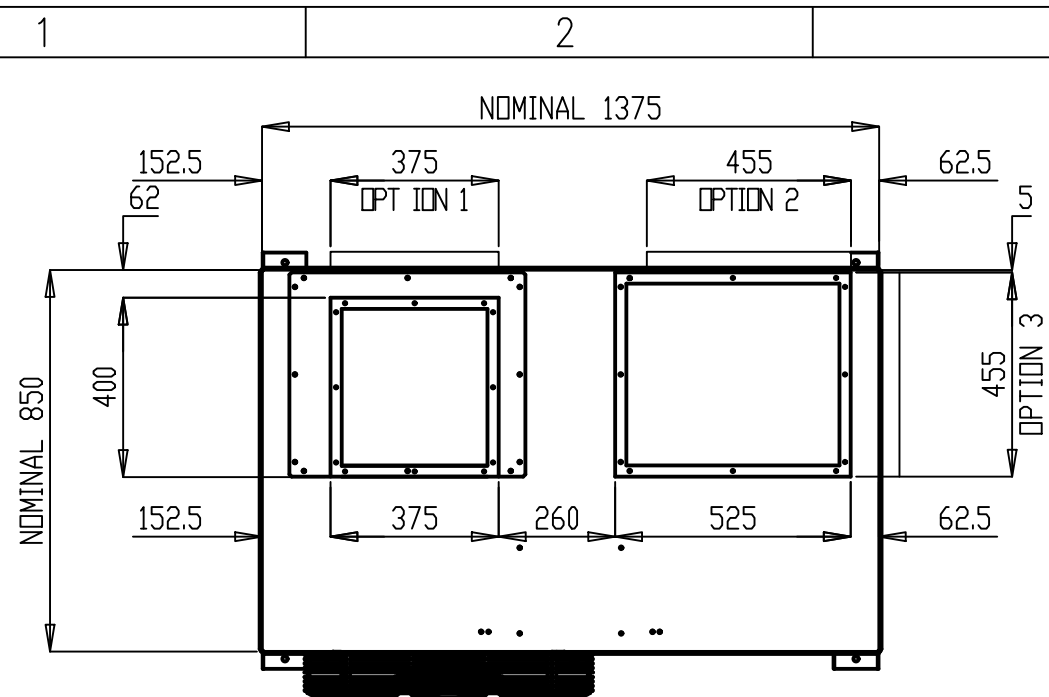

AIR OFF PLAN

NOTE: SEE SHEET 2 FOR OPTIONAL LID DIMENSIONS

- NOTES:
1. GENERAL ARRANGEMENT OF A VERTICAL PACKAGED UNIT
  2. POWER AND FIELD CABLE ENTRY, 1X 32 AND 2 X 25
  3. ELECTRICAL PANEL LOCATED BEHIND SERVICE ACCESS DOOR
  4. CONDENSATE OUTLET 20mm
  5. UNIT BASE 4 x 12 $\phi$  FIXING POINTS
  6. SUPPLY AIR IS TOP LEFT AS STANDARD. OR OPTION 1 REAR SUPPLY  
RETURN AIR IS TOP RIGHT AS STANDARD OR OPTION 2. REAR RETURN  
OPTION 3. SIDE RETURN
  7. OUTDOOR FAN IS ON FRONT AS STANDARD, OR OPTION 4 SIDE AIR OFF

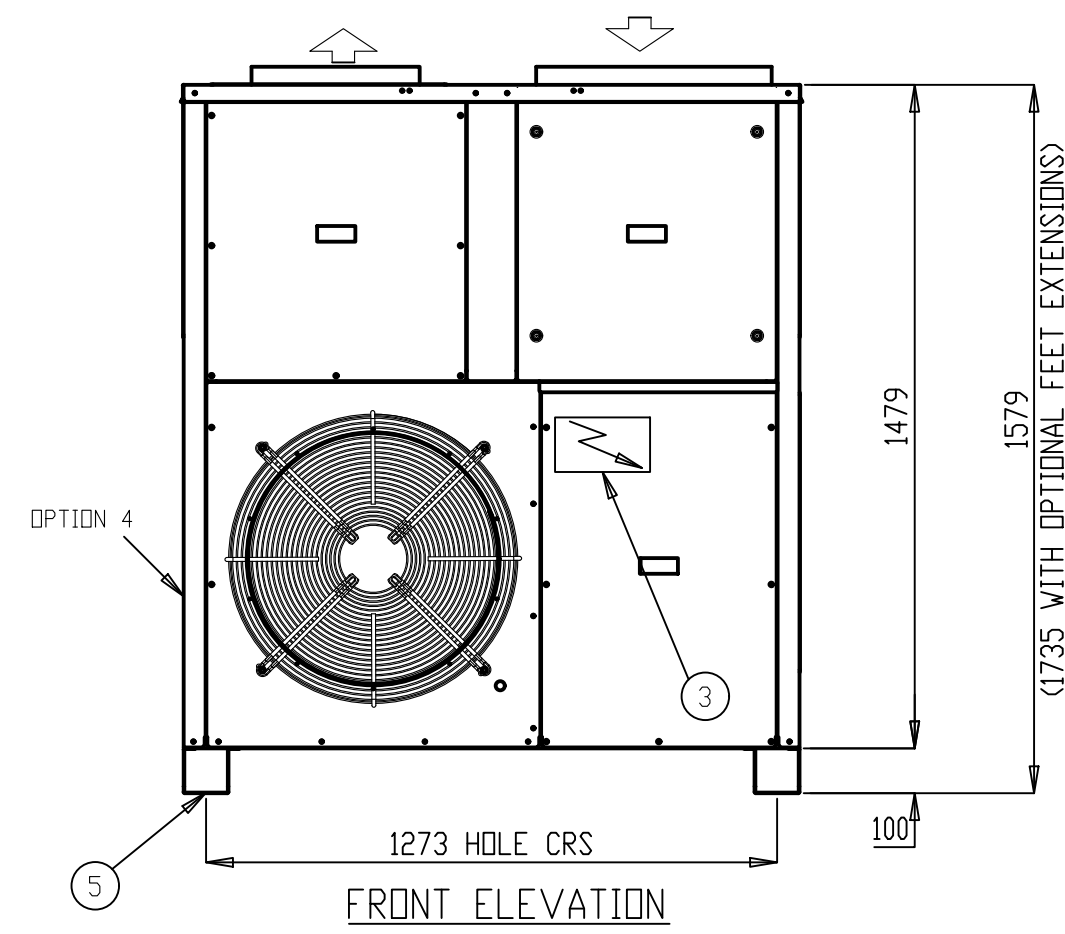

FRONT ELEVATION

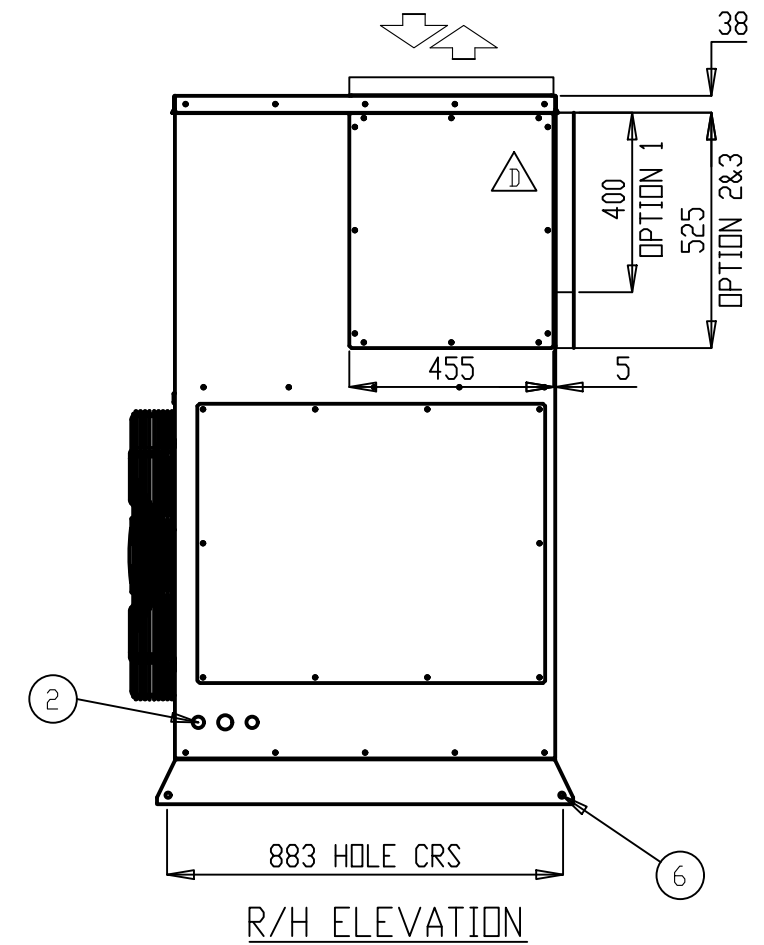

R/H ELEVATION

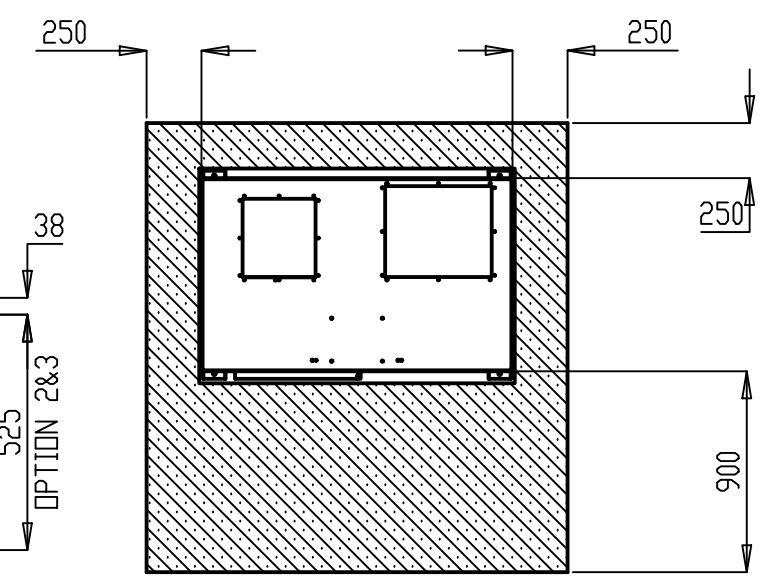

CLEARANCE DETAIL

- ALL DIMENSIONS IN mm.
- GENERAL TOLERANCE  $\pm 1$ mm.
- DO NOT SCALE DRAWING.
- MASTER DRAWINGS ARE HELD ELECTRONICALLY. ANY COPY IS DEEMED UNCONTROLLED AND THEREFORE NOT NECESSARILY THE LATEST REVISION.
- ALL INFORMATION REMAINS THE PROPERTY OF THE COMPANY.

# GENERAL ARRANGEMENT

Sheet 1 of 2

P012AVR3SA-LTT P015AVR3SA-LTT P018AVR3SA-LTT

www.apacair.com.au ABN: 74 005 138 769

REVISION	ADDED OPTION 1 DIMENSIONS TO R/H ELEVATION			
 ATLANTIC DR. KEYSBOROUGH VIC 3173 1300 555 545 by Rinnai	DRAWN	MT	DRAWING No. A4	
	DATE	24.03.16	GAD0059	
	SCALE	N.T.S.		
	CHECKED	HA	APP'D.	CM

1 2 3 4 5 6

A

A

B

B

C

C

D

D

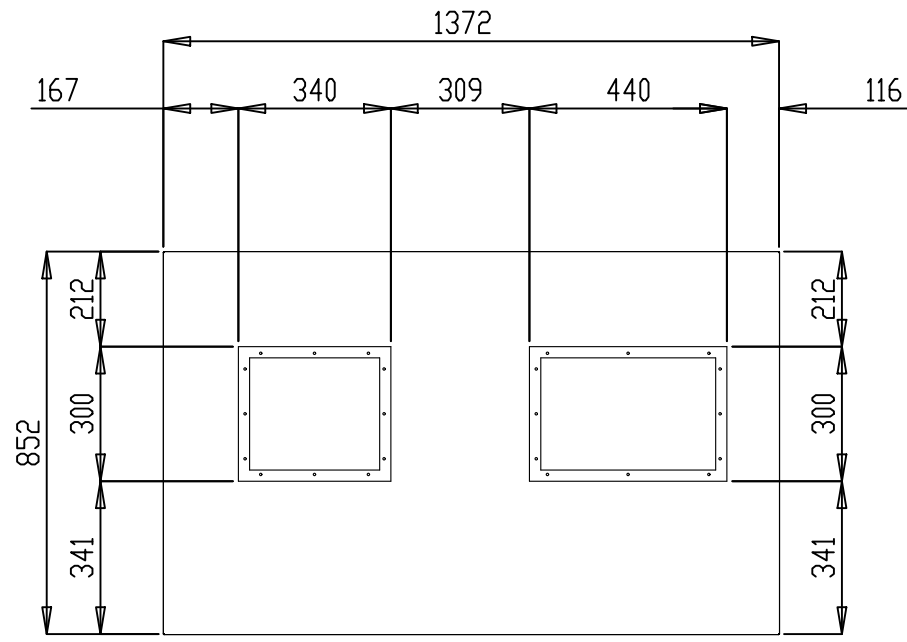

FRONT  
PLAN-OPTION A LID - LEFT HAND SUPPLY

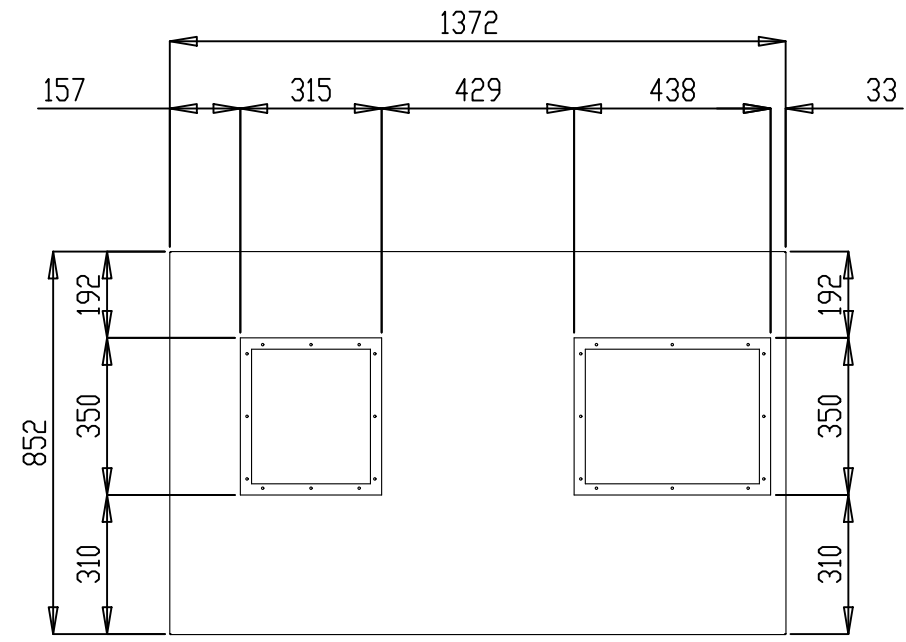

FRONT  
PLAN-OPTION B LID - LEFT HAND SUPPLY

- ALL DIMENSIONS IN mm.
- GENERAL TOLERANCE  $\pm 1\text{mm}$ .
- DO NOT SCALE DRAWING.
- MASTER DRAWINGS ARE HELD ELECTRONICALLY. ANY COPY IS DEEMED UNCONTROLLED AND THEREFORE NOT NECESSARILY THE LATEST REVISION.
- ALL INFORMATION REMAINS THE PROPERTY OF THE COMPANY.

GENERAL ARRANGEMENT  
Sheet 2 of 2

P012AVR3SA-LTT P015AVR3SA-LTT P018AVR3SA-LTT  
www.apacair.com.au ABN: 74 005 138 769

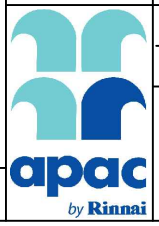
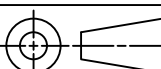
REVISION	ADDED OPTION 1 DIMENSIONS TO R/H ELEVATION				
		DRAWN	MT	DRAWING No.	A4
	ATLANTIC DR. KEYSBOROUGH VIC 3173 1300 555 545	DATE	24.03.16	GAD0059	
		SCALE	N.T.S.		
		CHECKED	HA	APP'D.	CM

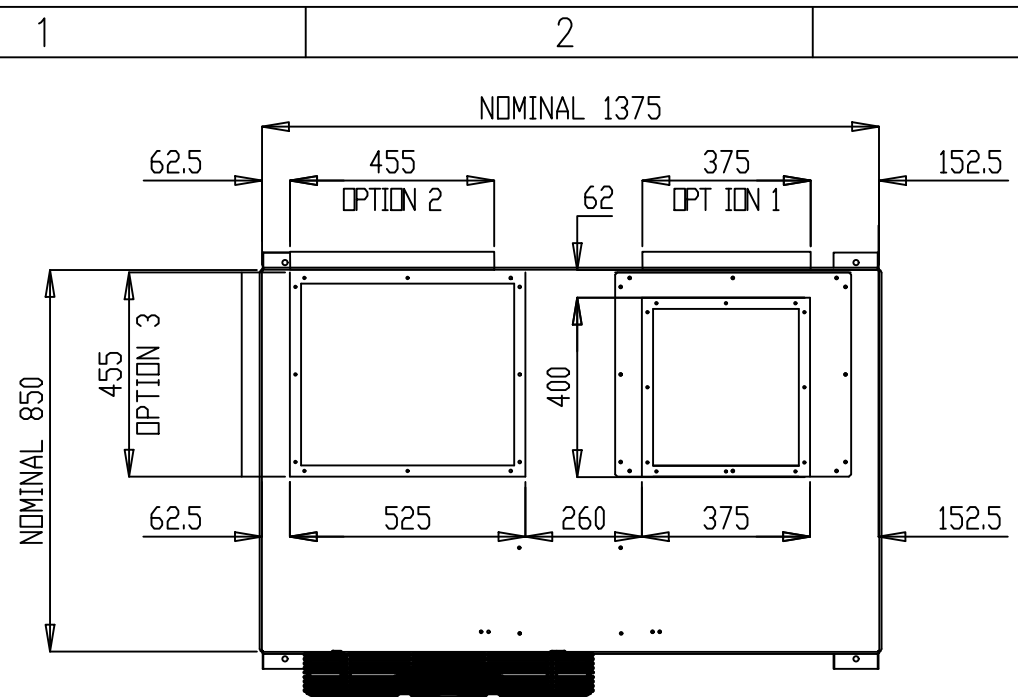

- NOTES:
1. GENERAL ARRANGEMENT OF A VERTICAL PACKAGED UNIT
  2. POWER AND FIELD CABLE ENTRY, 1X 32 AND 2 X 25
  3. ELECTRICAL PANEL LOCATED BEHIND SERVICE ACCESS DOOR
  4. CONDENSATE OUTLET 20mm
  5. UNIT BASE 4 x 12Ø FIXING POINTS
  6. SUPPLY AIR IS TOP RIGHT AS STANDARD. OR OPTION 1 REAR SUPPLY  
RETURN AIR IS TOP LEFT AS STANDARD OR OPTION 2. REAR RETURN  
OPTION 3. SIDE RETURN
  7. OUTDOOR FAN IS ON FRONT AS STANDARD, OR OPTION 4 SIDE AIR OFF

AIR OFF PLAN  
 NOTE: SEE SHEET 2 FOR OPTIONAL LID DIMENSIONS

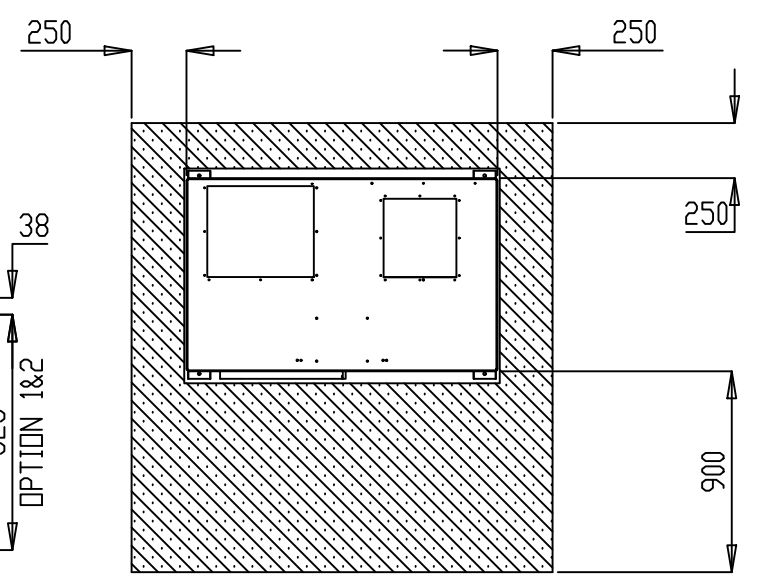
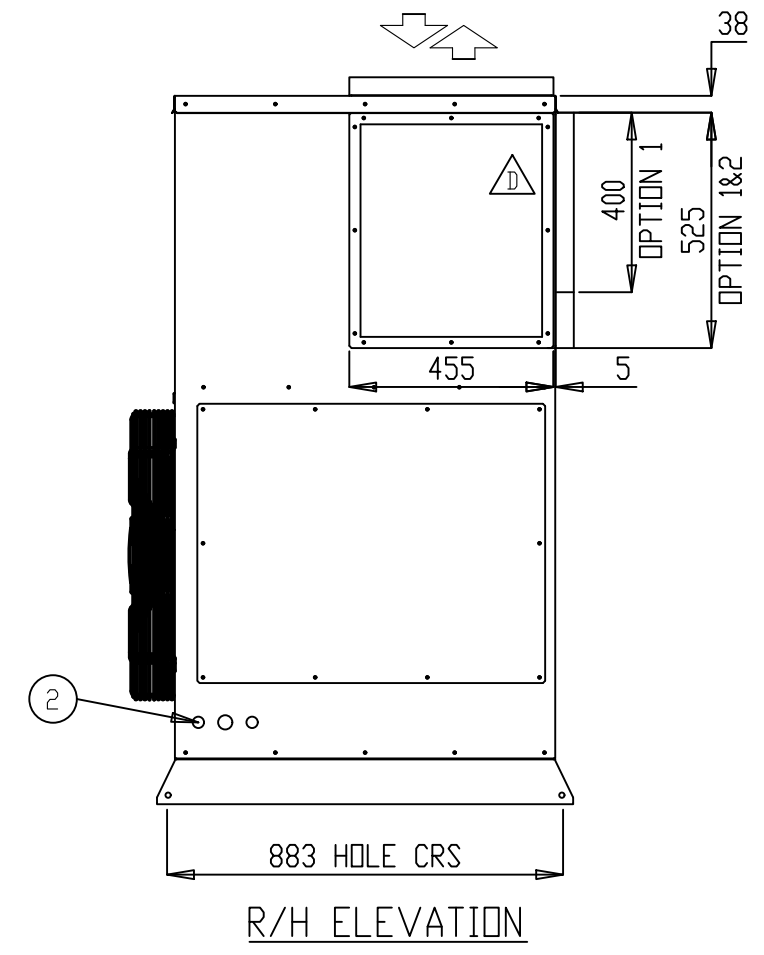
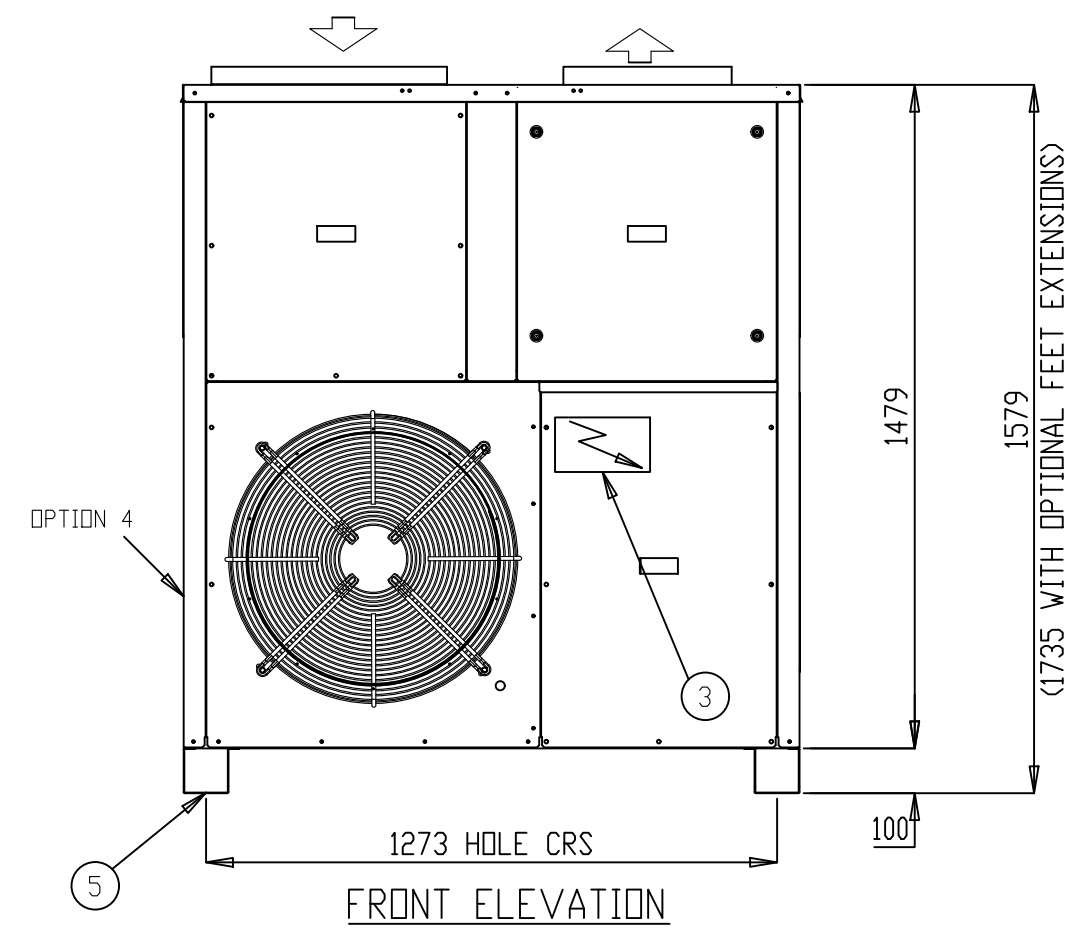

CLEARANCE DETAIL

- ALL DIMENSIONS IN mm.
- GENERAL TOLERANCE ±1mm.
- DO NOT SCALE DRAWING.
- MASTER DRAWINGS ARE HELD ELECTRONICALLY. ANY COPY IS DEEMED UNCONTROLLED AND THEREFORE NOT NECESSARILY THE LATEST REVISION.
- ALL INFORMATION REMAINS THE PROPERTY OF THE COMPANY.

GENERAL ARRANGEMENT  
 Sheet 1 of 2

P012AVR3SA-RTT P015AVR3SA-RTT P018AVR3SA-RTT  
 www.apacair.com.au ABN: 74 005 138 769

REVISION	ADDED OPTION 1 DIMENSIONS TO R/H ELEVATION			
 ATLANTIC DR. KEYSBOROUGH VIC 3173 1300 555 545 by Rinnai	DRAWN	MT	DRAWING No. A4	
	DATE	22.08.14	GAD0065	
	SCALE	N.T.S.		
	CHECKED	HA	APP'D.	CM

1

2

3

4

5

6

A

B

C

D

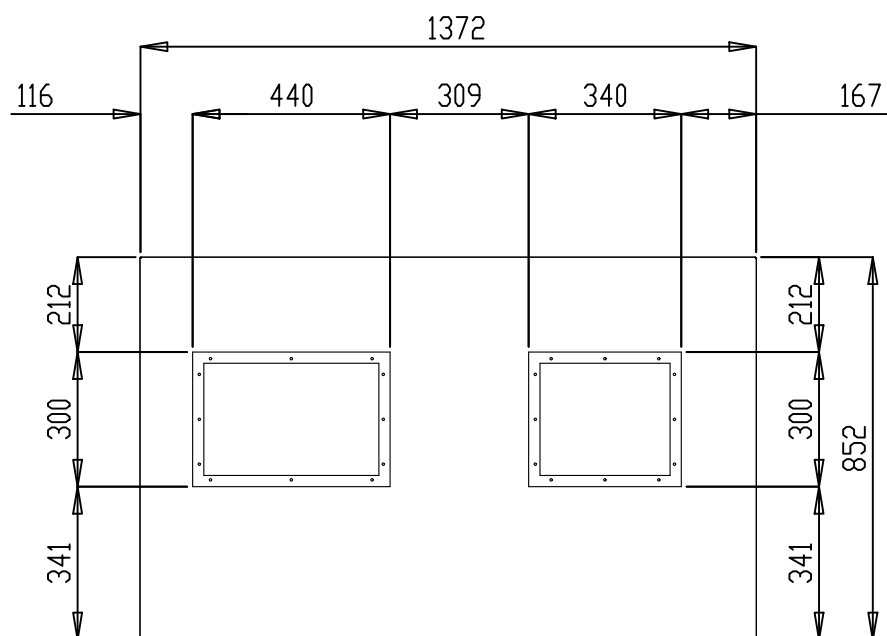

FRONT  
 PLAN-OPTION A LID - RIGHT HAND SUPPLY

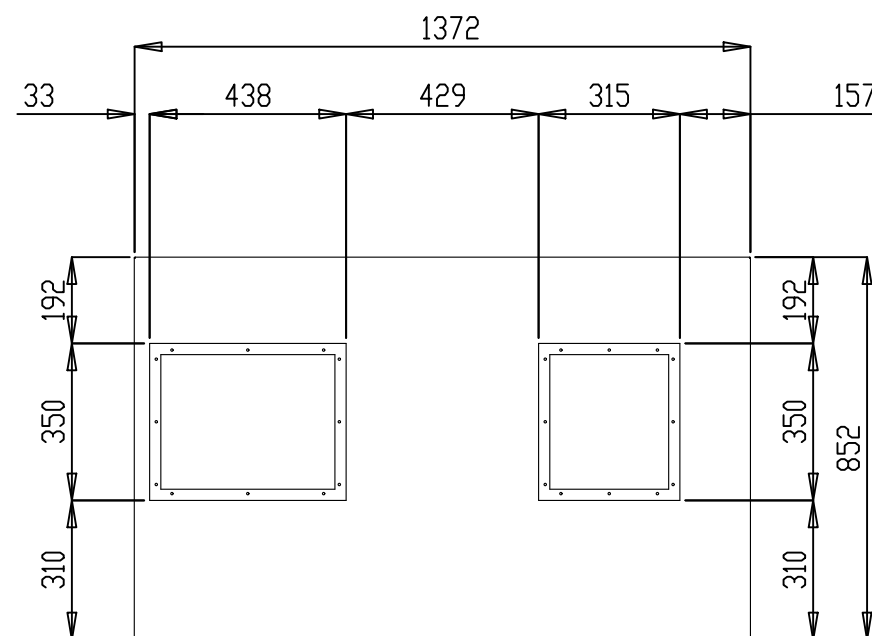

FRONT  
 PLAN-OPTION B LID - RIGHT HAND SUPPLY

- ALL DIMENSIONS IN mm.
- GENERAL TOLERANCE ±1mm.
- DO NOT SCALE DRAWING.
- MASTER DRAWINGS ARE HELD ELECTRONICALLY. ANY COPY IS DEEMED UNCONTROLLED AND THEREFORE NOT NECESSARILY THE LATEST REVISION.
- ALL INFORMATION REMAINS THE PROPERTY OF THE COMPANY.

## GENERAL ARRANGEMENT

Sheet 2 of 2

P012AVR3SA-RTT P015AVR3SA-RTT P018AVR3SA-RTT

[www.apacair.com.au](http://www.apacair.com.au)

ABN: 74 005 138 769

### REVISION

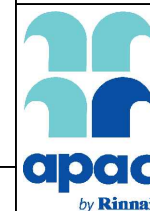

ADDED OPTION 1 DIMENSIONS TO R/H ELEVATION

ATLANTIC DR.  
KEYSBOROUGH  
VIC 3173  
1300 555 545

DRAWN	MT	DRAWING No.	A4
DATE	22.08.14	<b>GAD0065</b>	
SCALE	N.T.S.		
CHECKED	HA	APP'D.	CM
		REV.	D

## TECHNICAL DATA SHEET

MODEL NUMBER	P012AVR3SA-	P015AVR3SA-	P018AVR3SA-	P020AVR3SA-	P023AVR3SA-		
MEPS REGISTRATION NUMBER	AAC3310	AAC3305	AAC3309	AAC3317	AAC3308		
<b>CONDENSER SECTION</b>	<b>CAPACITY</b>						
	<b>Cooling</b>	kW TOTAL*	12.30	15.50	17.50	20.00	22.80
		kW SENSIBLE*	9.42	12.50	13.50	15.30	17.50
		EER (kW / ikW)*	3.52	3.60	3.43	3.39	3.28
	<b>Heating</b>	kW TOTAL	11.90	14.70	16.70	20.60	22.50
		COP	3.66	3.87	3.71	3.81	3.63
	CAPACITY STEPS (%)		0/100	0/100	0/100	0/100	0/100
	<b>COMPRESSOR</b>						
	TYPE		SCROLL	SCROLL	SCROLL	SCROLL	SCROLL
	STARTER TYPE		D.O.L (Opt Soft/Start)	D.O.L (Opt Soft/Start)	D.O.L (Opt Soft/Start)	D.O.L (Opt Soft/Start)	D.O.L (Opt Soft/Start)
	PHASE		3∅	3∅	3∅	3∅	3∅
	No. OFF		1	1	1	1	1
	PROTECTION DEVICES		HP SWITCH, LP SWITCH, MOTOR OVERLOAD'S				
	ALL COMPRESSORS HAVE		CRANKCASE HEATER				
	<b>FAN</b>						
	TYPE		AXIAL	AXIAL	AXIAL	AXIAL	AXIAL
	ikW (MAX INPUT)		0.39	0.39	0.39	0.60	0.60
	PHASE		1∅	1∅	1∅	1∅	1∅
	No. OFF		1	1	1	1	1
	FAN SPEED CONTROL		VARIABLE SPEED	VARIABLE SPEED	VARIABLE SPEED	VARIABLE SPEED	VARIABLE SPEED
	<b>HEAT EXCHANGER</b>						
	TYPE		PLATE FIN COIL	PLATE FIN COIL	PLATE FIN COIL	PLATE FIN COIL	PLATE FIN COIL
	NOM. AIRFLOW l/s		-	-	-	-	-
	<b>REFRIGERANT SYSTEM</b>						
TYPE		<b>R410A</b>					
CHARGE PER CIRCUIT (KG)		3.95	5.3	5.7	7.3	6.8	
No. OF CIRCUITS		1	1	1	1	1	
REFRIGERANT CONTROL		TXV					
ALL SYSTEMS INCLUDE		DRIERS & SIGHT GLASSES					
<b>EVAPORATOR SECTION</b>	<b>FAN</b>						
	TYPE		CENTRIFUGAL	CENTRIFUGAL	CENTRIFUGAL	CENTRIFUGAL	CENTRIFUGAL
	ikW (MAX INPUT)		1.7	1.7	1.7	1.7	1.7
	PHASE		3∅	3∅	3∅	3∅	3∅
	FAN SPEED CONTROL		VARIABLE SPEED	VARIABLE SPEED	VARIABLE SPEED	VARIABLE SPEED	VARIABLE SPEED
	<b>HEAT EXCHANGER</b>						
	TYPE		PLATE FIN COIL	PLATE FIN COIL	PLATE FIN COIL	PLATE FIN COIL	PLATE FIN COIL
	NOM. AIRFLOW l/s		625	835	875	990	1120
EXT STATIC pa		100					
<b>COMBINED SECTIONS</b>	<b>ELECTRICAL</b>						
	MAINS POWER		415v / 3∅ / 50hz	415v / 3∅ / 50hz	415v / 3∅ / 50hz	415v / 3∅ / 50hz	415v / 3∅ / 50hz
	H.P. CUT OUT / IN kPa		4500 / 3450	4500 / 3450	4500 / 3450	4500 / 3450	4500 / 3450
	L.P. CUT OUT / IN kPa		175 / 345	175 / 345	175 / 345	175 / 345	175 / 345
	NOM. R.L.A. (TOTAL SYSTEM)		5.60	6.88	8.50	9.72	12.40
	MAX. F.L.A. (TOTAL SYSTEM)		12.40	14.70	16.20	20.20	20.20
	<b>GENERAL</b>						
	CABINET		GALVANISED SHEET STEEL				
	INSULATION		ALUMINIUM FOIL FACED POLYETHYLENE ACOUSTIC INSULATION				
	EXTERNAL FINISH		POLYESTER POWDER COAT - COLOUR LIGHT GREY AS STANDARD - OPTIONS AVAILABLE				
	<b>DIMENSIONS</b>						
	H X W X D (mm)		1579 x 1370 x 850	1579 x 1370 x 850	1579 x 1370 x 850	1965 x 1370 x 850	1965 x 1370 x 850
	<b>WEIGHT</b>						
	OPERATING KG		250	270	270	300	300
	SHIPPING KG		255	275	275	362	372
	<b>NOISE LEVELS [Based on condenser fan's sound data]</b>						
Sound Power db(A)		63.5	63.5	63.5	66.9	66.9	

**Note:** All units are MEPS complaint. Tested in accordance with AS/NZS 3823.1.2

\*Performance excludes ikW of evaporator fan motor.

R.L.A - Run Load Amps are based on current drawn at nominal conditions

F.L.A - Full Load Amps are based on the overload settings [Max Current] of all Compressor and Fan Motor(s).

Date	Document #	Approved By	Revision
27/6/18	TDS0014	CM	H

## FAN PERFORMANCE CURVE

**P012AVR3SA-**

**FAN PERFORMANCE CURVE P012AVR3SA-**

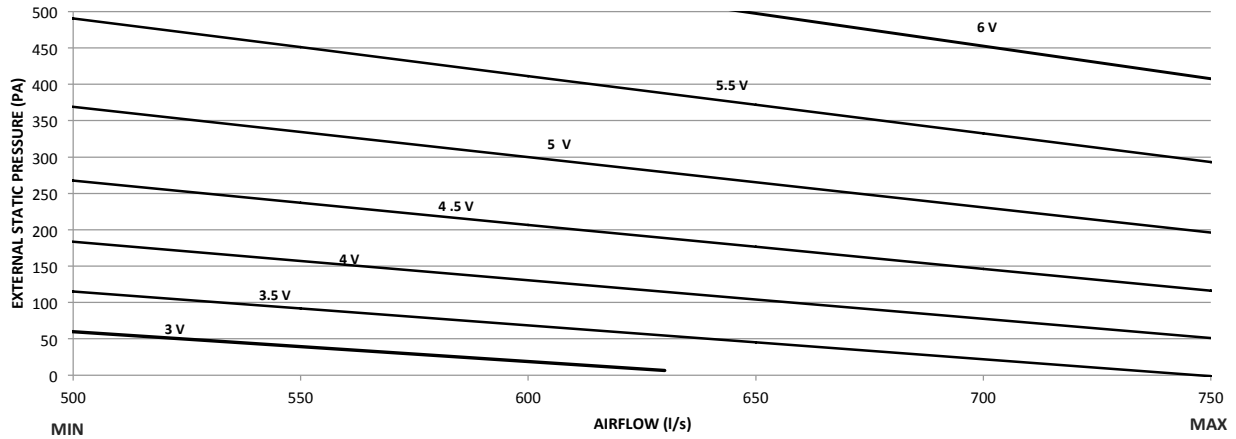

Note:

1. 3V, 3.5V, 4V, 4.5V, 5V, 5.5V and 6V represents potentiometer voltage. Potentiometer can be adjusted to achieve desired flowrates.
2. Potentiometer voltage can be varied infinitely between 0 to 10V.

Date	Document #	Approved By	Revision
29.05.18	FPC0048	CM	B

**NOTE: Due to continuous improvement Rinnai Australia Pty Ltd reserve the right to change details without notice.**



# SOUND DATA

**MODEL NUMBER**

**P012AVR3SA-**

**Outdoor Fan**

Sound Power Level dB(A)	Octave band Centre Frequency (hz), dB						
	125	250	500	1k	2k	4k	8k
63.5	69.2	58.6	58.9	58.8	56.8	49.9	47.1

**Indoor Fan**

Sound Power Level dB(A)	Air Flow (l/s)	Octave band Centre Frequency (hz), dB						
		125	250	500	1k	2k	4k	8k
72.2	625	56.2	65.7	64.5	67.7	66.1	63.3	60.4

Date	Document #	Approved By	Revision
01.06.18	SD0039	CM	B

**NOTE: Due to continuous improvement Rinnai Australia Pty Ltd reserve the right to change details**



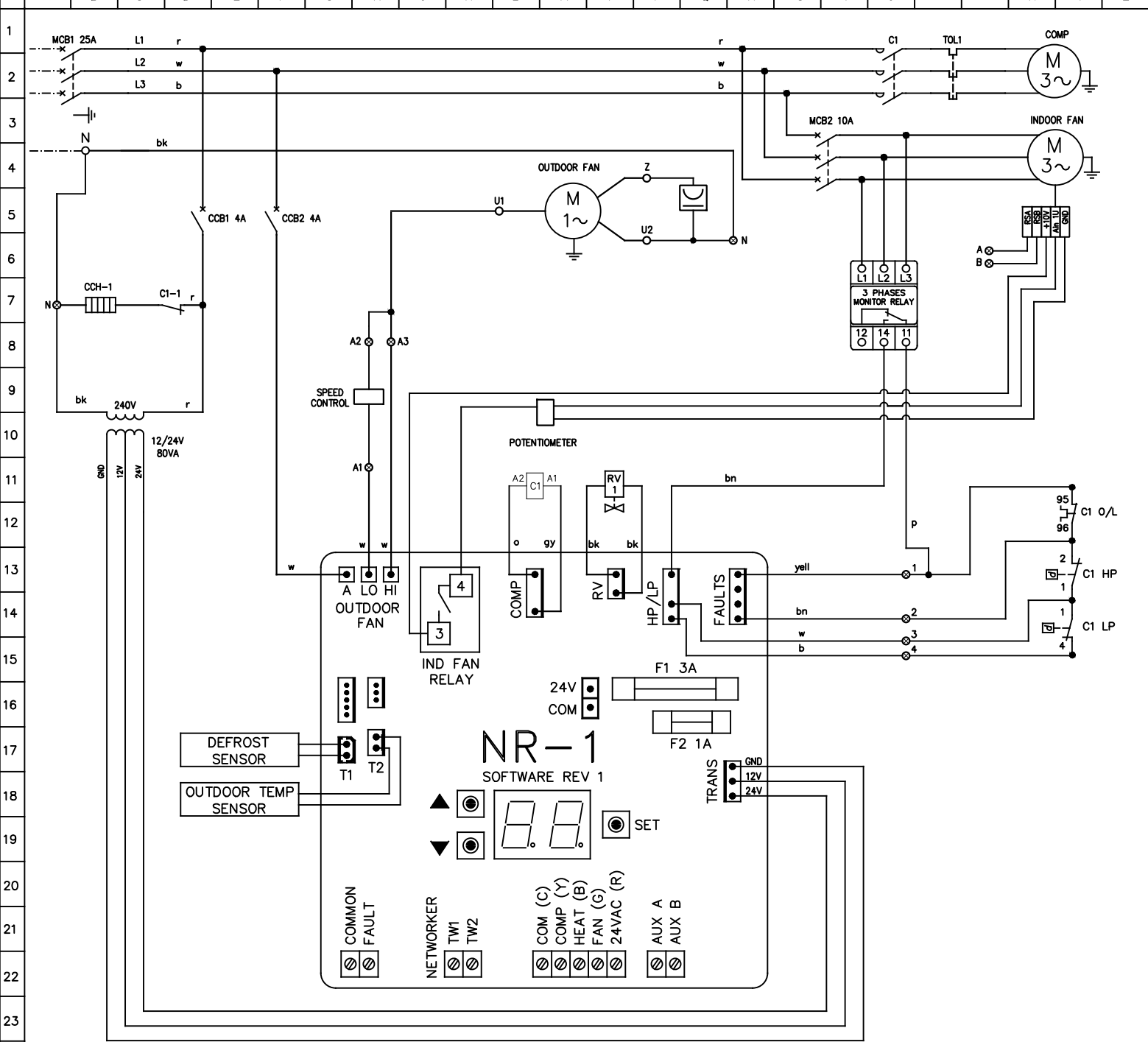

	TYPE	ID	SETTING	
INDOOR FAN OPERATION DURING DEFROST PARAMETER SETTING	INSTALLER	5	1	UPON COMPLETION OF SETTING THE PARAMETERS, SYSTEM (SAFETY SWITCHES, OVERLOADS, LOCKOUT) MUST BE TESTED TO ENSURE CORRECT OPERATION.
FAULT INPUT PARAMETER SETTING	SERVICE	11	1	
		12	0	
		13	0	
		14	1	

- NOTES: 1. THERMAL OVERLOAD RELAYS, HP SWITCH AND LP SWITCH ARE AUTO RESET, UNLESS OTHERWISE STATED.  
 2. ALL FIELD WIRING IS THE RESPONSIBILITY OF THE INSTALLING CONTRACTOR, AND MUST COMPLY WITH AS/NZS 3000 AND LOCAL RULES.

**WARNING:** THE SOFTWARE OF THE NR-1 CONTROLLER IS NOT DESIGNED TO FUNCTION AS A PRIMARY PERSONAL SAFETY DEVICE, AS CONNECTED EQUIPMENT CAN START AUTOMATICALLY WITHOUT WARNING. ALSO OPENING THERMOSTAT CONTACTS OR SWITCHING OFF ON THE NC4 NETWORKER MAY NOT CAUSE THE EQUIPMENT TO STOP. THE ELECTRONIC CONTROLLER HAS A BUILT IN AUTOMATIC RESET FAULT LOCKOUT FUNCTION AND MAY RESTART THE SYSTEM AUTOMATICALLY WITHOUT WARNING.  
 OUTDOOR FAN MOTORS HAVE INTERNAL OVERLOADS AND MAY RESTART AUTOMATICALLY.

**IMPORTANT NOTE:** THE SCROLL COMPRESSOR IS ROTATIONALLY SENSITIVE, IF NOISY OR NOT PUMPING, CHANGE ANY OF TWO PHASES.

LEGEND		LEGEND		COLOUR CODE	COMPRESSOR (EACH)	MODEL: P012AVR3SA	
COMP	COMPRESSOR CONTACTOR	---	FIELD WIRING	r	RED	OPTIONS	
C1	CONTACTOR OVERLOAD	---	MAINS/CONTROL WIRING	w	WHITE		DESCRIPTION
O/L	THERMAL OVERLOAD	---	CONTROL PARAMETER	b	BLUE	STANDARD	
TOL	CRANK CASE HEATER	---	SWITCHBOARD TERMINAL	bk	BLACK		
CCH.	REVERSING VALVE	⊗	TERMINAL	bn	BROWN		
RV1.	HIGH PRESSURE SWITCH	○		o	ORANGE		
HP.	LOW PRESSURE SWITCH			p	PINK		
LP.	MINIATURE CIRCUIT BREAKER			pl	PURPLE		
MCB	BREAKER			gy	GREY		
CCB	CONTROL CIRCUIT BREAKER			yell	YELLOW		
					kw	2.83	
					RATED CURRENT	8.00	REF
					O/L SETTING	8.80	A
					FANS (EACH)	kw	FLA
					OUTDOOR	0.39	1.78
					INDOOR	1.70	2.60

DATE: 3/07/2018  
 DWN: S.P APPD ENG  
 REV: A GRID B99  
 DWG No: EWS02093